



Hackney Carriage and Private Hire Licensing Policy 2023 - 2027

Date policy adopted: 30 November 2022

Adopted by: Cabinet

Date of implementation: 1 April 2023

Next review period: 1 April 2026 to 31 March 2027

CONTENTS

<u>Policy</u>	Page
<u>Part 1 - Introduction</u>	4
<u>Part 2 - Licensing Principles, Process and Delegation</u>	9
<u>Part 3 - Licensable Activities</u>	15
• <u>3a Hackney Carriage and Private Hire Drivers</u>	19
• <u>3b Hackney Carriages</u>	35
• <u>3c Standard Private Hire Vehicles</u>	56
• <u>3d Executive Private Hire Vehicles</u>	77
• <u>3e Novelty Private Hire Vehicles</u>	99
• <u>3f Private Hire Operators</u>	118
<u>Part 4 - Compliance, Enforcement and Complaints</u>	132
<u>Part 5 - Consultation</u>	134
<u>Part 6 - Licensing Contact Details</u>	136
<u>Appendices</u>	
<u>Appendix A - Safeguarding of Children, Young People and Adults (including those with Care and Support Needs)</u>	139
<u>Appendix B - Hackney Carriage and Private Hire Drivers Licence - Conditions of Licence</u>	144
<u>Appendix C - Hackney Carriage Licence - Conditions of Licence</u>	153
<u>Appendix D - Standard Private Hire Vehicle Licence - Conditions of Licence</u>	161
<u>Appendix E - Executive Private Hire Vehicle Licence - Conditions of Licence</u>	169
<u>Appendix F - Novelty Private Hire Vehicle Licence - Conditions of Licence</u>	176
<u>Appendix G - Private Hire Operator Licence - Conditions of Licence</u>	184
<u>Appendix H - Plying for Hire</u>	199
<u>Appendix I - Guidance to Determining the Suitability of Applicants including the Relevance of Criminal Convictions and Cautions</u>	201

<u>Appendix J - Specifications for a Reference Wheelchair</u>	215
<u>Appendix K - Intended Use and Licensing of Hackney Carriages</u>	217
<u>Appendix L – Use of Information on and in relation to Hackney Carriages and Private Hire Vehicles</u>	221
<u>Appendix M - Conditions Applicable to the Use of Trailers</u>	223

PART 1

INTRODUCTION

PART 1 – INTRODUCTION

Scope

- 1.0 The Hackney Carriage and Private Hire Licensing Policy ('the Policy') is applicable to the licensing of hackney carriage and private hire drivers and vehicles and to the licensing of private hire operators. This Policy supersedes all previous Council policies relating to hackney carriages, private hire vehicles, operators and drivers.

Purpose

- 1.1 The fundamental purpose of the Policy is to protect the safety and welfare of the public who live, work and visit Shropshire. The importance of a thriving hackney carriage and private hire trade to the growth and prosperity of Shropshire's local economy is recognised. Almost everyone in our society occasionally uses licensed vehicles; however, they are regularly used by particularly vulnerable groups, including children, the elderly, disabled people and the intoxicated. Given that a licensed driver has significant power over a passenger who, in effect, places themselves and their personal safety completely in the hands of the driver, it is imperative that the safety and welfare of the public is the over-riding principle that will be considered when matters are dealt with under the Policy.
- 1.2 Shropshire Council ('the Council') is particularly concerned to ensure:
- the safeguarding of children, young persons and adults (including those with care and support needs)
 - a zero tolerance approach towards modern slavery and human trafficking (modern slavery is a crime and a violation of fundamental human rights and can take various forms such as slavery, servitude, forced and compulsory labour and human trafficking)
 - that the action to promote the welfare of children, young persons and adults (including those with care and support needs) and to protect them from harm is everyone's responsibility, in particular, prospective and licensed drivers and operators who will have dealings with children and families have a duty to report matters of concern that could relate to the safety of children, young persons and adults (including those with care and support needs) to the relevant authorities (refer to **Appendix A** for further information)
 - that any person who applies to be a hackney carriage or private hire vehicle driver, proprietor or operator is a fit and proper person and does not pose a threat (in any form) to the public
 - that the public are safeguarded from dishonest persons
 - that hackney carriage and private hire drivers, private hire operators and vehicle proprietors recognise the significant responsibility and pivotal roles they have in relation to protecting the public, particularly with respect to ensuring robust sub-contracting arrangements are in place and effectively managed and promoting and maintaining high standards of consumer protection and customer service across their entire business operation
 - that the hallmark of the regulatory licensing regime is localism and that the local authority responsible for granting licences ought to have the authority to exercise full control over all vehicles and drivers being operated within its area. The Council believes that the increasing prevalence of cross-border hiring can undermine local licensing control. Public safety is being threatened and environmental aspirations diluted in cases where drivers/vehicle proprietors 'shop around' to be licensed by local authorities that

demand the lowest standards and then exclusively or predominantly work in an area or areas where standards are higher and licences more difficult to obtain

- that vehicles used to convey passengers are safe and fit for the purpose for which they are licensed
- that the impact on the environment is reduced in line with European and national guidelines and the Councils Climate Change Strategy Framework¹

1.3 The Policy provides guidance to any person with an interest in hackney carriage and private hire licensing; in particular, but not restricted to:

- persons who wish to apply for hackney carriage and private hire vehicle, drivers or operator licences
- persons who hold existing licences, including those that are the subject of review
- the Council, in its capacity as the licensing authority, including licensing officers, members of the relevant licensing committees and the Licensing Panel (or other relevant decision making bodies)
- licensing consultants, solicitors and barristers advising and/or representing applicants/licence holders
- magistrates and judges hearing appeals against Council decisions

1.4 The Policy is designed to put the Council's licensing requirements into context in accordance with relevant legislation. It is not the intention of this Policy to outline every section of the legislation throughout the proposed policy document and applicants are advised to either consider the legislation directly or obtain independent legal advice.

Consultation and Communication

1.5 In determining the Policy, the Council has consulted as set out on page 148. The views of relevant stakeholders have been taken into consideration.

1.6 In order to deliver a transparent, accountable and efficient licensing service the Council is committed to ongoing communicating and consultation with all stakeholders. In particular, the Council welcomes the opportunity to communicate and consult with representatives of the hackney carriage and private hire trade to enable and encourage the exchange of views and information in relation to the Policy, conditions, changes in the law and reviews. The specific methods to achieve this communication and consultation will be determined as required.

Review of the Policy

1.7 The Council will commence a review of the Policy in 2026 with the aim of a revised policy being effective from 1 April 2027. However, it will be the subject of continuous evaluation and, if necessary, formally reviewed at any time. At the time of review all relevant stakeholders will again be consulted. Any licensed driver or operator may request a review of the policy at any time.

1.8 The Council does not stipulate through this Policy the colour of a licensed vehicle. However, the Council has agreed that the trade be encouraged, particularly when considering vehicle replacement, to adopt the following approach:

- All hackney carriages to be of a uniform black colour

¹ [Shropshire Climate Change Strategy Framework](#)

- All private hire vehicles to be of a uniform colour and NOT black

Legislative framework

- 1.9 The operation of the Council’s licensing service is undertaken in accordance with relevant legislation, applicable licence conditions, the Regulators’ Code (BRDO 14/705 April 2014), the Department for Transport Taxi and Private Hire Vehicle Licensing: Best Practice Guidance (March 2010), the Statutory Taxi and Private Hire Vehicle Standards (July 2020), the Taxi and Private Hire Vehicles (Safeguarding and Road Safety) Act 2022², the Taxis and Private Hire Vehicles (Disabled Persons) Act 2022³, the Air Quality (Taxi and Private Hire Vehicles Database) (England and Wales) Regulations 2019: Statutory guidance⁴, the Immigration Act 2016, the Equality Act 2010, Finance Bill 2021 (Tax Conditionality) and such other guidance that may be issued from time to time by the Department for Transport and other Government departments.
- 1.10 The primary legislation relating to hackney carriage and private hire licensing is contained in the Town Police Clauses Act 1847 and the Local Government (Miscellaneous Provisions) Act 1976. In addition, the service is provided in accordance with all relevant Council policies, but in particular those that relate to the following:
- Protection of children, young persons and adults (including those with care and support needs)
 - Better regulation and enforcement
 - Data protection including access to information
 - Public sector equality duty
 - Human rights⁵
- 1.11 The Policy and associated conditions do not address health and safety at work requirements. Drivers and operators are required to ensure all relevant health and safety at work provisions are satisfied.
- 1.12 The Policy and associated conditions do not address requirements under the Road Traffic Act 1988 and other relevant road traffic legislation, e.g., the Highway Code, parking restrictions and traffic regulation orders.

Conditions

- 1.13 The applicable conditions with which a driver, proprietor or operator must comply are set out at **Appendix B – Appendix G**. These conditions are in addition to any matters set out within the main body of the Policy.
- 1.14 When determining applications or reviewing an existing licence, the Council will adopt any reasonable conditions that it deems necessary and appropriate to ensure that proprietors, operators, drivers and vehicles comply with relevant legislation and the fundamental purpose of

² <https://www.gov.uk/government/publications/taxis-and-private-hire-vehicles-safeguarding-and-road-safety-act-2022/taxis-and-private-hire-vehicles-safeguarding-and-road-safety-act-2022>

³ <https://www.gov.uk/government/publications/access-to-taxis-and-private-hire-vehicles-for-disabled-users/access-to-taxis-and-private-hire-vehicles-for-disabled-users--2>

⁴ <https://www.gov.uk/government/publications/air-quality-taxis-and-private-hire-vehicles-phvs-database-guidance/the-air-quality-taxi-and-private-hire-vehicles-database-england-and-wales-regulations-2019-statutory-guidance>

⁵ Human Rights Act 1998, in particular, Article 1, Protocol 1 – peaceful enjoyment of possessions (a licence is considered a possession in law and people should not be deprived of their possessions except in the public interest); Article 4 - prohibition of slavery and forced labour; Article 6 – right to a fair hearing; Article 7 – no punishment without law; Article 8 – respect for private and family life (in particular, removal or restriction of a licence may affect a person’s private life); Article 10 – right to freedom of expression; and Article 14 - prohibition of discrimination.

the Policy, i.e. to protect the safety and welfare of the public. Any licensed driver, vehicle proprietor or operator aggrieved by a decision of the Council, with respect to a refusal to grant or renew a licence and to suspend or revoke a licence or to attach additional conditions to a licence, has a right of appeal to the appropriate Court.

PART 2

LICENSING

PRINCIPLES, PROCESS

AND DELEGATION

PART 2 – LICENSING PRINCIPLES, PROCESS AND DELEGATION

Introduction

- 2.0 The Council has adopted Part II of the Local Government (Miscellaneous Provisions) Act 1976 and, together with the provisions contained in the Town Police Clauses Act 1847, the Council carries out the licensing of hackney carriage drivers and vehicles and private hire drivers, vehicles and operators.
- 2.1 This part of the Policy focusses on the principles the Council will follow when administering licence applications, reviewing current licences, reviewing conditions, setting fees and setting the hackney carriage table of fares. It explains the roles and duties of the Strategic Licensing Committee, the Licensing and Safety Sub-Committee, the Licensing Panel and officers of the Council.
- 2.2 Where appropriate, any reference to ‘applicant’ is deemed to include existing licence holders. In respect of proprietors and operators ‘applicant’ also includes any partners, directors/company secretaries.

Licensing principles

- 2.3 The licensing process is neither civil nor criminal in nature; it is quasi-judicial. In other words, licensing powers and functions are undertaken by the Council in a similar way to powers and functions that are exercised by a judge in a court of law.
- 2.4 The Council aims to provide a clear, consistent and responsive service to prospective and current licence holders, members of the public and other stakeholders. This includes the provision of advice to prospective applicants, including advice on the effect that convictions, cautions, driving endorsements, complaints etc. may have on any application, and to existing licence holders. The Council will be mindful of the needs of the applicant but this will be balanced against the over-riding duty that the Council has to protect the safety and welfare of the public.
- 2.5 All licence applications will be considered and determined on their own individual merits.

Licensing process and delegation of functions

- 2.6 The licensing of hackney carriages and private hire vehicles, drivers and operators is a Council function that is discharged by the Council’s Strategic Licensing Committee in accordance with Shropshire Councils Constitution⁶. The Strategic Licensing Committee has delegated this function to the Licensing and Safety Sub-committee, a Licensing Panel where officers with delegated authority will make licensing decisions and to officers of the Council who will determine all applications in accordance with this Policy.
- 2.7 An individual may approach a Shropshire Council Councillor to act as their representative. However, members of the Strategic Licensing Committee may be unable to act as their representative where there is a conflict of interest. Any Councillor who is a member of the Licensing and Safety Sub-committee determining an application or review of a licence may not act as a representative. If there is any doubt, the individual is advised to contact the Council’s Legal & Democratic Services for clarification.

⁶ In accordance with Part 4 Council Procedure Rules, Licensing and Safety Sub-Committee Procedure Rules and Part 8 Delegations, Director of Public Health. The Councils Constitution can be found at <https://shropshire.gov.uk/legal-and-democratic-services/our-constitution>

- 2.8 Whilst officers and the relevant committees will, in the majority of cases, follow the Policy, there may be specific circumstances that require a departure from the Policy. In such circumstances, the reasons for departing from the Policy will be made clear.

Committees and licensing panel

2.9 Strategic Licensing Committee

This Committee is made up of 15 members of the Council. It deals with policy issues, sets standard conditions of licence, the setting of fees and charges and hackney carriage fares.

2.10 Licensing and Safety Sub-committee

This Committee is made up of a selection of Members from the Strategic Licensing Committee. Five to six Members (Quorum of 3) will sit on hearings to deal with new applications, renewals and reviews of licences that are referred by officers. Members, when determining applications for a licence, renewals or reviews of a licence, will have regard to hackney carriage and private hire legislation, this Policy, the Department for Transport Taxi and Private Hire Vehicle Licensing Best Practice Guidance (March 2010), the Statutory Taxi and Private Hire Vehicle Standards (July 2020), the Taxi and Private Hire Vehicles (Safeguarding and Road Safety) Act 2022, the Taxis and Private Hire Vehicles (Disabled Persons) Act 2022, the Road Traffic Act 1988 and other relevant road traffic legislation, the Human Rights Act 1998, the Equality Act 2010, any relevant legal case law and other relevant Council policies.

2.11 Licensing Panel

The Panel is an internal mechanism set up by the Council to assist and support the officers who have delegated authority to make licensing decisions⁷. The manager responsible for licensing will make a decision in consultation with a legal adviser and other officers considered appropriate. Currently, the Panel consists of a licensing officer and representatives from adult and children's safeguarding and is attended by a Council solicitor in their capacity as an independent legal adviser. The Panel assists and supports officers with delegated authority to determine new applications, renewals and reviews of licences that are referred directly by a licensing officer. Matters, where the officer with delegated authority is unable to reach a decision, or for any other reason so agreed by that officer, will be referred to the Licensing and Safety Sub-committee for determination.

Decisions

- 2.12 The Council, by virtue of a duly authorised officer, has the power to refuse to grant or renew licences and also to suspend or revoke existing licences in accordance with relevant legislative provisions. In addition, the Council may choose to issue written warnings or advice.
- 2.13 Any decision to refuse to grant or renew a licence or to suspend or revoke an existing licence, including the decision to suspend or revoke a drivers licence with immediate effect, or to issue a written warning or advice will be made in accordance with the Council's scheme of delegation and other relevant procedures.

⁷ In accordance with Part 4 Council Procedure Rules, Licensing and Safety Sub-Committee Procedure Rules and Part 8 Delegations, Director of Public Health. The Councils Constitution can be found at <https://shropshire.gov.uk/legal-and-democratic-services/our-constitution>

- 2.14 The Council will consider each case on its own individual merits and when making a decision will determine what action is appropriate and proportionate to the circumstances of the case. Decisions are made based on a civil not criminal standard of proof, i.e. on the balance of probabilities, is something more likely than not to be the case. The Council is not required to prove matters beyond reasonable doubt.
- 2.15 Where applications are to be determined, the Council will take into consideration the facts of the application, any information and/or evidence provided by other interested parties including, but not restricted to, other licensing authorities, officers from the Council with responsibility for safeguarding and passenger transport contracts, and officers from West Mercia Police. In order to provide applicants with the opportunity to consider and respond by way of written and/or verbal representations, as appropriate, the Council will provide the relevant details which have given rise to the need for an officer decision and/or hearing.
- 2.16 Following the determination of an application by the Council the applicant will receive a copy of the decision in writing. This written decision will be issued as soon as is practicable after the decision has been made and within 14 days. This will include information on the right of appeal where appropriate.

NB If the Council receives information in relation to any safeguarding or road safety concerns about a hackney carriage or private hire driver who is licensed by another licensing authority, the relevant information will be shared with that authority.

Appeals

- 2.17 Parties aggrieved by a decision of the Council, with respect to a refusal to grant or renew a licence and to suspend or revoke a licence or to attach additional conditions to a licence have a right of appeal to the appropriate Court. This must be lodged with the Court in accordance with the relevant statutory provisions. The Council strongly advises parties to promptly seek appropriate independent legal advice in such circumstances.

Statutory Taxi and Private Hire Vehicle Standards

- 2.18 On the 21 July 2020 the Secretary of State for Transport published new Statutory Taxi and Private Hire Vehicle Standards (the Standards) to all licensing authorities. The Standards are an important first step in reforming the way the taxi and private hire vehicle sector is regulated.
- 2.19 The Standards are aimed at achieving a consistent national standard for safeguarding children and vulnerable adults and were developed to set-out a range of robust measures to protect taxi and private hire vehicle passengers, particularly those most vulnerable.
- 2.20 Shropshire Council is under a legal duty, under section 177 of the Police and Crime Act 2017, to have regard to the Standards.
- 2.21 The requirements of the Standards have been considered and incorporated within the Councils Policy.
- 2.22 There is already clear alignment between the Council's Policy and the majority of the requirements set out in the Standards. Nevertheless, for the purposes of decision making, the requirements of the Standards will take precedence.

National register for hackney carriage and private hire licence revocations, refusals and suspensions

- 2.23 The national register for hackney carriage and private hire licence revocations, refusals and suspensions (NR3S) (or equivalent if this is replaced) is an online database which contains information about applicants for a hackney carriage or private hire drivers licence who have been refused or revoked. The information is used to assist local authorities to determine if an applicant is 'fit and proper' to hold such a licence.
- 2.24 On new and renewal applications the Council will make enquiries through NR3S in order to ensure the Council is in a position to make as accurate an assessment of the applicant's fitness to hold a licence as is reasonably practicable. If a search of NR3S indicates a match with an applicant, the authority will seek further information about the entry on the register from the authority which recorded it.
- 2.25 With specific reference to existing licence holders, where there is any cause for a licence to be reviewed, the Council will make additional enquiries through the national register for hackney carriage and private hire licence revocations, refusals and suspensions (or equivalent if this is replaced), in order to ensure the Council is in a position to make as accurate an assessment of the licence holders fitness to hold a licence as is reasonably practicable.
- 2.26 The Council will record the basic details of applicants and licence holders who have had their licence refused, revoked or suspended on the national register for hackney carriage and private hire licence revocations and refusals.
- 2.27 The information recorded on NR3S will be limited to:
- Name
 - Date of birth
 - Address and contact details
 - National insurance number
 - Driving licence number
 - Decision taken
 - Date of decision
 - Date decision effective
 - If a suspension, the date on which the suspension is to end
- 2.28 Information will be retained on NR3S for a period of 11 years.
- 2.29 Recording information on NR3S does not mean that an applicant will be automatically prevented from obtaining a licence in the future. The information is intended to ensure that licensing authorities are able to access an applicants full licensing history should an applicant apply to a different local authority. Where a request is received from another local authority, the Council may provide its reasons for the refusal or revocation of a licence.

Cross-border hiring

- 2.30 Cross-border hiring is a term used to describe a situation where private hire vehicles or hackney carriages, that are licensed by one licensing authority work in another licensing authority area.

- 2.31 This situation poses a potential risk to public safety, as well as the reputation of local government as a whole. Consequently, the Council recognises the responsibility it has to use all appropriate mechanisms and opportunities, including working with and supporting other local authorities, to protect communities outside of its immediate responsibility.

Working in partnership

- 2.32 The Council aims to work in partnership when dealing with hackney carriage and private hire licensing issues. Such partnerships will include, but are not restricted to, relevant hackney carriage and private hire trade associations, Telford & Wrekin Council, City of Wolverhampton Council and other local authorities, West Mercia Police and other relevant police forces, Driver and Vehicle Standards Agency (DVSA), the Home Office, UK Border Agency, Her Majesty's Revenue and Customs (HMRC), Revenues and Benefits teams, disability groups and consumer groups.
- 2.33 However, it must be recognised that the Council, as primary regulator, will ensure that all relevant provisions relating to the effective administration of licensing functions are robustly enforced to protect the public.

PART 3

LICENSABLE ACTIVITIES

PART 3 – LICENSABLE ACTIVITIES

Introduction

- 3.0 This part of the Policy focusses on the licensable activities and the necessary steps required to obtain and hold such a licence. These steps will include the standards that applicants must attain and the conditions that apply. Where appropriate, any reference to ‘applicant’ is deemed to include existing licence holders. Where appropriate, any reference to ‘employ’ or ‘employment’ is deemed to include hackney carriage or private hire drivers who may be contracted on a self-employed basis and used to fulfil bookings.
- 3.1 The following are applicable to all licence types:
- Where an applicant has failed to declare relevant information or provided false information (e.g. failure to declare convictions including where the Council has brought the prosecution or is likely to be aware of the conviction through other means, giving false names or addresses, providing falsified references or failing to disclose in full the information requested by the Council), the application is likely to be refused; where this relates to an existing licence, the licence is likely to be revoked. Applicants are reminded that it is an offence to knowingly or recklessly make a false statement/declaration or omit any material particularly when giving information required by the application for a licence.
 - The Council is committed to ensuring that it provides a quality and efficient service to every customer; however, there are rare instances where a customer unnecessarily takes up a large amount of resources. This can lead to a detrimental effect on the ability of the Council to provide a satisfactory level of service to its other customers. Unreasonably persistent and vexatious customers are those individuals who, because of the nature or frequency of their contacts with the Council, hinder the Council’s ability to effectively deliver services to its customers. Where an applicant demonstrates unreasonably persistent and vexatious behaviour the Council will take a very robust stance when deciding whether or not a person is fit and proper to hold a licence granted by the Council. Detailed guidance is available on the Councils website at <http://www.shropshire.gov.uk/feedback/corporate-complaints/>.
 - All licence fees are payable at the time of application. Where a licence is not granted, e.g. the applicant withdraws their application; a proportion of the licence fee will be refunded. In the event of an appeal, the Council will only consider a refund after any appeal period has passed and on confirmation from the Councils Legal Team that that an appeal has not been lodged. The actual amount of the refund will depend upon the progress of the application.
 - The application process must be completed within 6 months unless prevented from doing so by matters that are outside the applicant’s control, e.g. external delays in the Disclosure and Barring Service (DBS) process. When an application is not completed within this timescale the application will be referred to the Licensing Panel for determination where an officer with delegated authority will consider each case on its own individual merits and will determine what action is appropriate and proportionate to the circumstances of the case.
 - Where a licence has been surrendered or revoked a new application must be submitted in accordance with the relevant new licence procedures before the Council will consider the application.
 - When a licence expires, the Council will not permit any ‘periods of grace’ for the submission of a renewal application unless there is satisfactory evidence of exceptional circumstances that are accepted by the Council.

Appointments

- 3.2 The Council runs an appointment system. Applicants will not be seen without an appointment.
- 3.3 To assist operators, drivers and proprietors to be allocated appointments in a timely manner, the Council will notify all operators, drivers and proprietors of vehicles that their licence is due to expire at least four weeks before the actual expiry of a licence. This is not a legal requirement and responsibility for ensuring that an application for renewal is submitted before the expiry of the licence lies solely with the operator, driver and proprietor.

Criminal record disclosure

- 3.4 The Council follows the Disclosure and Barring Service (DBS) Revised Code of Practice for Disclosure and Barring Service Registered Persons (November 2015) and abides by the handling of DBS certificate information requirements on the secure storage, handling, use, retention and disposal of disclosure certificates and certificate information. Further information about the DBS can be found on the GOV.UK website at: <https://www.gov.uk/government/organisations/disclosure-and-barring-service/about>
- 3.5 The Council will accept an Enhanced DBS disclosure certificate issued as part of an application made through a separate organisation providing:
- It has been applied for with a Barred Lists check, under the Other Workforce criteria, and is for a relevant role
 - The original DBS certificate is presented to the Council
 - The applicant has subscribed to the DBS Update Service
 - The applicant has authorised the Council to access the relevant online record
- 3.6 It is a requirement of the Councils application process that an applicant must subscribe to the DBS Update Service within 30 calendar days of the issue date as stated on the DBS certificate.
- 3.7 The DBS Update Service allows the Council to check the status of an existing DBS certificate, providing permission has been given by the applicant and providing the certificate applies to the same workforce and where the same type and level of criminal record check is required.
- 3.8 The Council will undertake online status checks of existing enhanced DBS certificates throughout the currency of the licence to check if any new information has come to light since its issue.
- 3.9 The DBS Update Service will provide the Council with one of the following three statuses:
1. This DBS certificate did not reveal any information and remains current as no further information has been identified since its issue.
 - This means the DBS certificate when issued was blank - it did not reveal any information about the person and no new information has been found since its issue and can therefore be accepted as being still current and valid.
 2. This DBS certificate remains current as no further information has been identified since its issue.

- This means the DBS certificate revealed information about the person and no new information has been found since its issue and can therefore be accepted as being still current and valid.
3. This DBS certificate is no longer current. Please apply for a new DBS check to get the most up-to-date information.
- This means new information has come to light since the DBS certificate was issued and an applicant will need to apply and pay for a new DBS check to see this new information.
- 3.10 All licensed drivers must evidence continuous registration to the DBS Update Service throughout the licence period.
- 3.11 Shropshire Council has a duty under the Safeguarding Vulnerable Groups Act 2006, Sections 41 and 43, to refer a person to the DBS where the person is a regulated activity provider and Shropshire Council have withdrawn permission for said person to engage in regulated activity. Further information can be found in **Appendix I**.
- 3.12 Drivers who undertake work for Shropshire Council's transport contracts are advised that the Licensing Team will share DBS information with the Council's Passenger Transport Team. The Passenger Transport Team will share information with the Licensing Team about individuals and businesses that apply and/or tender to deliver passenger transport contracts and any complaints that they receive. Conversely, the Licensing Team will share information with the Passenger Transport Team where concerns are raised in regard to the conduct of a licensed driver.

Public registers

- 3.13 The Council maintains a public register for hackney carriages, private hire vehicles, operators and drivers in accordance with the provisions contained within the Local Government (Miscellaneous Provisions) Act 1976 and the Town Police Clauses Act 1847.

List of designated wheelchair accessible vehicles

- 3.14 The Council maintains a list of designated wheelchair accessible vehicles in accordance with the provisions contained within the Equality Act 2010. Further information can be found at 3a.88, 3b.33, 3c.32, 3d.41, 3e.37 and 3f.94.

Summary

- 3a.1 Any person who drives a hackney carriage must hold the appropriate vehicle driver's licence. Hackney carriage vehicle driver's licences are issued in accordance with section 46 of the Town Police Clauses Act 1847 and section 59 of the Local Government (Miscellaneous Provisions) Act 1976.
- 3a.2 Any person who drives a licensed private hire vehicle must hold the appropriate vehicle driver's licence. Private hire vehicle driver's licences are issued in accordance with section 51 of the Local Government (Miscellaneous Provisions) Act 1976.
- 3a.3 The Council will issue a drivers licence to applicants who meet the fit and proper person test and this will permit the driving of both hackney carriage and private hire vehicles, unless an applicant makes a specific request to the Council for either a hackney carriage driver licence or a private hire vehicle driver licence.

Fit and proper person

- 3a.4 Licensed drivers provide a public service. The Council will not licence anyone to drive a hackney carriage or private hire vehicle unless it is satisfied that they meet all the criteria to be deemed a fit and proper person as set out in **Appendix I**.
- 3a.5 In considering the fit and proper person test, all applicants on initial application must complete an enhanced Disclosure and Barring Service (DBS) check and undergo a medical examination. Unless already subscribed to the DBS Update Service, all applicants on renewal must complete an enhanced Disclosure and Barring Service (DBS) check. On new and renewal applications the Council will also make additional enquiries through the national register for hackney carriage and private hire licence revocations, refusals and suspensions (or equivalent if this is replaced), its adults and childrens social care teams, directly with West Mercia Police (and other relevant police forces, where appropriate), other relevant local authorities (particularly Telford & Wrekin Council and City of Wolverhampton Council) and any other appropriate organisation, agency or person in order to ensure the Council is in a position to make as accurate an assessment of the applicant's fitness to hold a licence as is reasonably practicable.
- 3a.6 With specific reference to existing licence holders, where there is any cause for a licence to be reviewed, the Council will make additional enquiries through the national register for hackney carriage and private hire licence revocations, refusals and suspensions (or equivalent if this is replaced), its adults and childrens social care teams system (or equivalent if this is replaced), directly with West Mercia Police (and other relevant police forces, where appropriate), other relevant local authorities (particularly Telford & Wrekin Council and City of Wolverhampton Council) and any other appropriate organisation, agency or person in order to ensure the Council is in a position to make as accurate an assessment of the licence holders fitness to hold a licence as is reasonably practicable. Depending on the circumstances of the case, the Council may request the licence holder to consent to a further enhanced DBS check, the cost of which lies with the licence holder. Where a licence holder refuses to consent to a further check the Council will take this into consideration in determining their continuing fitness to hold a licence.

- 3a.7 Where an existing licence holder has had their licence refused, revoked or suspended the details will be recorded on the national register for hackney carriage and private hire licence revocations, refusals and suspensions (or equivalent if this is replaced). Furthermore, where the Council receives a request for further information from another licensing authority, it must provide the reasons for refusal, revocation or suspension.
- 3a.8 When assessing the fitness of an applicant to hold a drivers licence, the Council will consider the applicant's criminal history as a whole, together with all other relevant evidence, information and intelligence including their history (e.g. complaints and positive comments from the public, compliance with licence conditions and willingness to co-operate with licensing officers) whilst holding a licence from the Council or any other authority. Particular attention will be given to patterns of behaviour, irrespective of the time-scale over which they have occurred, both in terms of proven criminal offences and other behaviour/conduct that may indicate the safety and welfare of the public may be at risk from the applicant.
- 3a.9 In addition, an important element associated with the fitness to hold a licence is the appearance (be clean and respectable in their dress and person and maintain a high standard of personal hygiene) and behaviour of a licensed driver. Consequently, the Council requires all licensed drivers to maintain a reasonable standard of appearance and behaviour when in contact and dealing with all persons, including but not limited to, other road users, pedestrians, customers, the general public, other licensed operators and drivers of hackney carriage and private hire vehicles, Council officers and elected members at all times. Applicants and licensed drivers must also co-operate with any reasonable request made by an authorised officer of the Council or any police officer.
- 3a.10 It must also be recognised that the Council will consider all criminal history, behaviour and conduct irrespective of whether the specific history, behaviour or conduct occurred whilst drivers were directly engaged in hackney carriage or private hire licensed work at the time or whether they occurred during the drivers' own personal time. The Council considers a person or individual who has a propensity to commit offences and/or demonstrate unacceptable conduct whilst not engaged in hackney carriage or private hire work to be equally as serious as offences and/or unacceptable conduct committed whilst engaged in hackney carriage or private hire work.

Criminal record disclosure

- 3a.11 As referred to above, hackney carriage and private hire vehicle drivers are required to undertake an enhanced criminal record disclosure (DBS check) and due to the nature of the occupation such drivers are deemed to be an exempt occupation under the provisions of the Rehabilitation of Offenders Act 1974 (by virtue of the amended Rehabilitation of Offenders Act 1974 (Exceptions) Order 1975).
- 3a.12 The effect of this, in relation to hackney carriage and private hire drivers, is to render the Rehabilitation of Offenders Act 1974 inapplicable and therefore convictions are deemed never to be spent, unless they are considered a protected conviction or caution. Further information on protected convictions and cautions can be found in **Appendix I**. As a result, all convictions, including cautions, which are not protected will be taken into account when considering a person's suitability to hold a driver's licence. Consequently, applicants are required to provide details of all unprotected convictions and cautions, including driving endorsements (driving convictions) and disqualification periods relating to traffic offences.
- 3a.13 Although cautions are generally not as serious as convictions, ordinarily as a result of the circumstances under which they are offered, they do require an admission of guilt before they can

be issued which is equivalent to a guilty plea on prosecution. Consequently, a caution is regarded in exactly the same way as a conviction. Fixed penalties, community resolutions or similar sanctions will also be considered in the same way as a conviction on the basis that payment of a fixed penalty indicated an acceptance of guilt and a community resolution can only be imposed following an admission of guilt. As a result, each of these sanctions is a valuable indication as to an applicant's character and whether they are a fit and proper person to hold or be granted a licence.

- 3a.14 A criminal record does not automatically bar an applicant from holding a drivers licence; however, it will be a significant factor when determining whether a licence ought to be granted or not. Where an applicant has previous criminal convictions, these will be considered in line with the guidance set out in **Appendix I**. However, the over-riding consideration will always be to ensure the safety and welfare of the public.
- 3a.15 Applicants who have spent three continuous months or more living outside the United Kingdom from the age of 18, prior to submitting an application, will be required to produce a certificate of good conduct or equivalent document (at their own cost) issued by the relevant Embassy or High Commission. The certificate must be authenticated, translated and sealed by the Embassy or High Commission. In the event that an applicant is not able to obtain a certificate of good conduct, they may submit a statutory declaration with regard to their conduct, which must be completed in the presence of a practising solicitor. The Council may contact the relevant Embassy, High Commission, solicitor or other appropriate body to verify any documents provided. Contact details for Embassies and High Commissions can be found from the Foreign, Commonwealth & Development Office (FCDO) on the GOV.UK website at <https://www.gov.uk/government/world>. The FCDO may be contacted for further assistance by telephone on 020 7008 5000, by email at fcdo.correspondence@fcdo.gov.uk or by post at the FCDO, King Charles Street, London, SW1A 2AH.
- 3a.16 Applicants who have spent three continuous months or more living outside the United Kingdom, during the period of their licence, will be required to produce a certificate of good conduct or equivalent document (at their own cost). This certificate must be issued by the relevant Embassy or High Commission for the country or countries lived in during this period and meet the requirements as set out at 3a.15 above. It is recognised that some countries will not provide a certificate of good conduct unless the individual has been resident for six months or more. Where a relevant Embassy or High Commission refuse to issue a certificate of good conduct, applicants must provide written confirmation from the Embassy of any refusal to the Licensing Team.

Right to work

- 3a.17 The Immigration Act 2016 amended existing licensing requirements in the UK to prevent illegal working in the hackney carriage and private hire licensing trade. With effect from 1 December 2016, the provisions in the Immigration Act 2016 prohibits all licensing authorities across the UK from issuing a licence to anyone who is disqualified by reason of their immigration status.
- 3a.18 All applicants must provide evidence of their right to work in the UK in accordance with the Home Office requirements. For further information see: <https://www.gov.uk/government/publications/licensing-authority-guide-to-right-to-work-checks>.

HMRC tax check

- 3a.19 The Finance Bill 2021 introduced new tax check requirements for applicants for a hackney carriage/private hire drivers licence. For further information see: <https://www.gov.uk/guidance/complete-a-tax-check-for-a-taxi-private-hire-or-scrap-metal-licence>.
- 3a.20 With effect from 4 April 2022, new applicants for a hackney carriage/private hire drivers licence, if applying for a licence for the first time, will be required to read HMRC guidance on their responsibilities and will be required to confirm via the application process that this has been done.
- 3a.21 Applicants applying to renew a hackney carriage/private hire drivers licence or new applicants that hold, or have held, a similar licence within the previous 12 months, will be subject to a tax check to demonstrate that they are registered for tax.

Non-conviction information

- 3a.22 In addition to conviction/caution information, applicants are expected to provide details, within 48 hours of all warnings, driving endorsements (driving convictions)/disqualification periods relating to traffic offences, fixed penalties, penalty charge notices, community resolutions and any other similar sanctions, together with any charges or arrests that they are the subject of in connection with criminal offences, whether or not actually charged with the offence, and details of any allegations of involvement in criminal activity or where they have been questioned in connection with any alleged criminal activity or inappropriate/unacceptable behaviour or any other relevant pending matter.
- 3a.23 Where an applicant is the subject of an outstanding charge or summons, their application may continue to be processed; however, depending on the circumstances, it is unlikely that a decision on the application will be made until the conclusion of the criminal proceedings. Where the outstanding charge or summons involves a serious offence and/or the individual's offending history and behaviour/conduct indicates a pattern of unlawful or unacceptable behaviour/character traits, then the application is likely to be refused.
- 3a.24 Where there is evidence/information that an applicant has been arrested or charged but not convicted of offences and the nature of this evidence/information suggests the applicant may not be a fit and proper person, the Council will give serious consideration to refusing an application or revoking an existing licence.

Period of licence

- 3a.25 Driver licences will be issued for a period of three years or for a lesser period as the Council deems appropriate in the circumstances of the case.
- 3a.26 Licences will not be issued for a period that exceeds the permission given by the Home Office to live and work in the UK.

Application process

- 3a.27 The application form must be fully completed and include all relevant information, supporting documentation and appropriate fee.

- 3a.28 The full fee for the licence is payable at the time the application is submitted. For new applicants this includes the cost of the DBS check, DVLA check, the Council's hackney carriage and private hire drivers and operators safeguarding and disability awareness course, the initial driver assessment and the initial knowledge test. Where a new applicant has subscribed to the DBS Update Service and able to provide a DBS certificate that meets the Council's requirements as set out at Part 3 – Licensable Activities, paragraph 3.5, the fee for the licence will not include the cost of the DBS check. For renewal applicants this includes the cost of the DVLA check and the Council's hackney carriage and private hire drivers and operators safeguarding and disability awareness course.
- 3a.29 If any part of the application is incomplete, or the fee is not paid, the application will not be processed until such a time as all the information/documentation is provided. If the applicant fails to provide all the information to complete the application, the application will be rejected.
- 3a.30 Once an application has been accepted by the Licensing Team as a valid application the application process must be completed within 6 months unless prevented from doing so by matters that are outside the applicant's control, e.g., external delays in the DBS process. When an application is not completed within this timescale the application will be referred to the Licensing Panel for determination where an officer with delegated authority will consider each case on its own individual merits and will determine what action is appropriate and proportionate to the circumstances of the case.

New applications

- 3a.31 All new applicants must have held a full DVLA category B or European Economic Area (EEA) driving licence or a driving licence as recognised by The Road Traffic Act 1988 (section 108) or The Driving Licence (Exchangeable Licences) Order 1999 for at least 3 years at the time of application. This includes Northern Ireland, Gibraltar, Andorra, Australia, Barbados, British Virgin Islands, Republic of Cyprus, The Falkland Islands, The Faroe Islands, Guernsey, Hong Kong, Isle of Man, Japan, Jersey, Republic of Korea, Malta, Monaco, New Zealand, Singapore, Switzerland and Zimbabwe licences. The 3 year period is calculated from the date of issue of the full driving licence.
- 3a.32 In addition, applicants must:
- Submit a completed application form, which includes five year address history form and DVLA mandate form
 - Pay the appropriate licence fee
 - Provide a passport sized photograph, taken within the last three months, which shows a true likeness to the applicant
 - Provide evidence of their right to work in the UK in accordance with the Home Office requirements (for additional information see: <https://www.gov.uk/government/publications/licensing-authority-guide-to-right-to-work-checks>)
 - Have an enhanced DBS certificate. On initial application, the Council will accept an Enhanced DBS disclosure certificate, issued as part of an application made through a separate organisation, providing the report meets the requirements set out in Part 3, paragraph 3.5 of the Policy
 - Provide the Council with the DBS certificate within 7 days of the date of receipt
 - Complete the Council's hackney carriage and private hire drivers and operators safeguarding and disability awareness course
 - Pass the Council's knowledge test

- Pass the road safety and driving ability test (driver assessment) or alternatively hold a current advanced motorist qualification undertaken in a motor car or minibus, and
- Submit a Group 2 medical report and certificate

3a.33 Once an application has been validated and accepted, the Council will:

- Issue appointments for completing a Disclosure and Barring Service (DBS) check, right to work check, completing the driver awareness course which includes the knowledge test, undertaking the driver assessment and completing the safeguarding and disability awareness course
- Make enquiries through the Councils adults and childrens social care teams, West Mercia Police (or other relevant force), other local authorities and any other organisation, agency or person that the Council has deemed appropriate to seek information from
- Complete an online DVLA driving licence check
- Make enquiries through the national register for hackney carriage and private hire licence revocations, refusals and suspensions (or equivalent if this is replaced)
- Where applicable, complete an online DBS Update Service check
- Where applicable, complete an online tax registration check

3a.34 It is a requirement of the Councils application process that the applicant must subscribe to the DBS Update Service within 30 calendar days of the issue date as stated on the DBS certificate.

3a.35 Providing Officers are satisfied that the applicant is a 'fit and proper' person, applying the Council's policy, a licence will be granted. In all other cases, the application will be referred to the Licensing Panel for determination. Each application will be decided on its merits. However, there is a presumption that unless an applicant can demonstrate exceptional circumstances the application will be refused. Whilst it is neither possible nor prudent to draw up a list of what might amount to exceptional circumstances, an applicant who claims that exceptional circumstances exist will be expected to be able to satisfy the Council that it would not frustrate the purposes of this Policy or compromise public safety if the licence were granted. The applicant will be notified in writing if their application is to be determined at a meeting of the Licensing Panel.

Renewal applications

3a.36 On renewal of an existing licence, applicants must:

- Submit a completed application form, which includes a five year address history form and DVLA mandate form
- Pay the appropriate licence fee
- Provide a passport sized photograph, taken within the last three months, which shows a true likeness to the applicant
- Complete a DBS disclosure. The Council will accept an Enhanced DBS disclosure report issued as part of an application made through a separate organisation providing the report meets the requirements set out in Part 3, paragraph 3.5 of the Policy
- Complete the Council's hackney carriage and private hire drivers and operators safeguarding and disability awareness course before an application is determined
- Where required, submit a Group 2 medical report and certificate (refer to paragraphs 3a.62 to 3a.70 below to determine whether a medical examination is/is not required)

3a.37 Once an application has been validated and accepted, the Council will:

- Issue appointments for completing a Disclosure and Barring Service (DBS) check, right to work check and completing the safeguarding and disability awareness course
- Make enquiries through the Councils adults and childrens social care teams, West Mercia Police (or other relevant force), other local authorities and any other organisation, agency or person that the Council has deemed appropriate to seek information from
- Complete an online DVLA driving licence check
- Complete an online DBS Update Service check
- Make enquiries through the national register for hackney carriage and private hire licence revocations, refusals and suspensions (or equivalent if this is replaced)
- Complete an online tax registration check

3a.38 It is a requirement of the Councils application process that the applicant must subscribe to the DBS Update Service within 30 calendar days of the issue date as stated on the DBS certificate.

3a.39 Providing the above are satisfied, the Council will renew the licence subject to the receipt of a satisfactory enhanced DBS certificate, satisfactory DVLA report and satisfactory reports through Councils adults and childrens social care teams, West Mercia Police (or other relevant force), other local authorities and any other organisation, agency or person that the Council has deemed appropriate to seek information from. It is the responsibility of the applicant to provide the Council with the DBS certificate within 7 days of the date of receipt. Failure to do so will result in the driver's licence being suspended or revoked.

3a.40 To allow continuous driving, a licence application must be received by the Council at least 10 working days prior to the expiry date of the current licence (unless there is satisfactory evidence of exceptional circumstances that are accepted by the Council) to allow the Council sufficient time to process the renewal application. It is the Council's intention to process all valid renewal applications within 10 working days; hence, where applicants fail to submit their renewal application within this timescale, the risk that their licence will expire increases. Once a licence expires, is revoked (subject to a statutory appeal process) or surrendered, it ceases to exist and applicants would not be permitted to drive a hackney carriage or private hire vehicle in these circumstances. **NB** Applicants are advised to ensure a renewal application is submitted in sufficient time to allow for the safeguarding and disability awareness course to be completed before their licence expires.

3a.41 Once a licence ceases to exist a renewal application will not be accepted by the Council (unless there is satisfactory evidence of exceptional circumstances that are accepted by the Council) and the applicant must submit a new driver's licence application which will be processed in accordance with the Council's new application procedures.

Arranging DBS, knowledge test, safeguarding and disability awareness course and driver assessment

3a.42 Appointments are made by the Council's licensing team with the applicant to complete a DBS application form, knowledge test, safeguarding and disability awareness course and driver assessment.

Language skills

3a.43 Applicants must be able to converse orally and in writing in English to a standard that would be reasonably expected of a person undertaking a role as a hackney carriage or private hire driver. A lack of language proficiency could impact on a driver's ability to communicate during an emergency and other challenging situations, and to understand written documents, such as policies and guidance, including those relating to the protection of children, young people and adults (including those with care and support needs). Drivers should be able to:

- Confidently read and understand the relevant policies and guidance to ensure they are fully aware of their duties and responsibilities
- Converse with passengers to demonstrate an understanding of the desired destination, an estimation of the time taken to get there and other common passenger requests
- Provide a customer with the correct change from a note or notes of a higher value than the requested fare, and
- Provide a legibly written receipt upon request

Hackney carriage and private hire drivers and operators safeguarding and disability awareness course

3a.44 Drivers must complete the Council's hackney carriage and private hire drivers and operators safeguarding and disability awareness course. Failure to complete this training will permit the Council to refuse to grant or to refuse to renew a driver's licence.

3a.45 Where an applicant arrives late and the safeguarding and disability awareness course has started, the applicant will be refused admission to the course. The Council will deem that the applicant has forfeited the course and the applicant will be required to take a subsequent course and pay the appropriate fee, unless the applicant is able to prove their late arrival was due to circumstances outside of their control. This is subject to a manager who has responsibility for licensing permitting a further course where the circumstances are considered appropriate.

3a.46 The charge for the initial safeguarding and disability awareness course is included in the licence fee. Once an appointment has been allocated for the course, the applicant must give 48 hours notice to cancel an appointment otherwise they will be required to pay the course fee.

Driver awareness course which includes the knowledge test

3a.47 Applicants for a licence to drive a hackney carriage or private hire vehicle will be required to take and pass the Council's knowledge test. This test is aimed at assessing the driver's knowledge of the Highway Code, the Councils Hackney Carriage and Private Hire Licensing Policy 2023-2027, equality and disability awareness, numeracy, writing a receipt and general geography of the Council's administrative area e.g., roads, in order to satisfy the Council that the applicant is fit and proper to hold a hackney carriage/private hire drivers licence. This test will be conducted in English. Details of the knowledge test requirements are provided on the Council's website and at the time the knowledge test booking is confirmed.

3a.48 Normal examination conditions will apply during the knowledge test. Any person found to be using unfair means during the test will be excluded from the test and will be required to take a fresh test and pay the appropriate fee. This may also affect their fitness and propriety to be granted a licence.

- 3a.49 Where an applicant arrives late and the knowledge test has started, the applicant will be refused admission to the course. The Council will deem that the applicant has forfeited the test and the applicant will be required to take a subsequent test and pay the appropriate fee, unless the applicant is able to prove their late arrival was due to circumstances outside of their control. This is subject to a manager who has responsibility for licensing permitting a further test or tests where the circumstances are considered appropriate.
- 3a.50 The charge for the initial knowledge test is included in the licence fee. Where an applicant fails the knowledge test there is an additional fee for every subsequent test and every missed test.
- 3a.51 Once an appointment has been allocated for the test, the applicant must give 48 hours notice to cancel an appointment otherwise they will be required to pay the test fee. In such circumstances the Council will deem that the applicant has failed the test.
- 3a.52 An applicant is permitted to take the knowledge test up to a maximum of 3 times per application, subject to the additional re-test fees being paid. Where an applicant fails the knowledge test three times, the application will be referred to the Licensing Panel where an officer with delegated authority may permit a further test or tests where an applicant can demonstrate that exceptional circumstances apply.
- 3a.53 The holder of a drivers licence may be required to satisfactorily undertake a further knowledge test or tests at the discretion/request of an officer with delegated authority (at a meeting of the Licensing Panel) or the Licensing and Safety Sub-Committee, as set out in Part 2, paragraph 2.14 of the Policy. An applicant is responsible for paying the fee for any subsequent knowledge tests.
- 3a.54 Failure to submit to or pass any knowledge test will permit the Council to refuse to grant or renew a driver's licence or to revoke or suspend the licence.

Road safety and ability test (driver assessment)

- 3a.55 Applicants for a licence to drive a hackney carriage or private hire vehicle will be required to take and pass the Council's driver assessment. This assessment aims to ensure drivers demonstrate a high degree of road safety awareness and excellent driving ability. Details of the assessment requirements are provided at the time the assessment booking is confirmed.

NB Applicants who hold a current advanced motorist qualification undertaken in a motor car or minibus may not be required to take and pass the Council's driver assessment.

- 3a.56 Where an applicant arrives late for the Council's driver assessment, the applicant will be turned away. The Council will deem that the applicant has forfeited the test and the applicant will be required to take a subsequent test and pay the appropriate fee, unless the applicant is able to prove their late arrival was due to circumstances outside of their control. This is subject to a manager who has responsibility for licensing permitting a further test or tests where the circumstances are considered appropriate.
- 3a.57 The charge for the initial driver assessment is included in the licence fee. Where an applicant fails the assessment there is an additional fee for every subsequent assessment and every missed assessment.

- 3a.58 Once an appointment has been allocated for the assessment, the applicant must give 48 hours notice to cancel an appointment otherwise they will be required to pay the assessment fee. In such circumstances the Council will deem that the applicant has failed the assessment.
- 3a.59 An applicant is permitted to take the assessment up to a maximum of 3 times per application, subject to the additional re-assessment fees being paid. Where an applicant fails the driver assessment 3 times, the application will be referred to the Licensing Panel where an officer with delegated authority may permit a further assessment or assessments where an applicant can demonstrate that exceptional circumstances apply.
- 3a.60 The holder of a drivers licence may be required to satisfactorily undertake a further driver assessment or assessments at the discretion/request of an officer with delegated authority (at a meeting of the Licensing Panel) or the Licensing and Safety Sub-Committee, as set out in Part 2, paragraph 2.14 of the Policy. An applicant is responsible for paying the fee for any subsequent driver assessments.
- 3a.61 Failure to pass any driver assessment will permit the Council to refuse to grant or renew a driver's licence or to revoke or suspend the licence.

Medical requirements

- 3a.62 The Council is permitted to satisfy itself that an applicant for a licence is mentally and physically fit and remains so during the currency of any licence. Consequently, all applicants for a hackney carriage or private hire vehicle driver's licence are required to undertake a medical examination on initial application, at defined intervals thereafter and at any other such time as the Council requires to ensure their fitness to drive. The standard required is the 'Group 2 Entitlement'. No grandfather rights are given by the Council in relation to medical matters. The standards required are set out in the DVLA publication 'Assessing fitness to drive – a guide for medical professionals' and can be found on the GOV.UK website at <https://www.gov.uk/government/publications/assessing-fitness-to-drive-a-guide-for-medical-professionals>.
- 3a.63 Applicants must undertake the medical examination and provide a satisfactory medical report and certificate before a licence is issued and then every 5 years from the age of 45, or sooner if stipulated by the examining doctor.
- 3a.64 Applicants over the age of 65 or who attain the age of 65 during a licensed period must undertake a medical examination and provide a satisfactory medical report and certificate annually.
- 3a.65 Applicants who have a condition identified within the DVLA publication 'Assessing fitness to drive – a guide for medical professionals' as requiring an annual review, will be required to provide a satisfactory medical report and certificate on an annual basis.
- 3a.66 In particular, applicants must consider the medical conditions listed in the DVLA publication 'Assessing fitness to drive – a guide for medical professionals' as the Council may refuse to grant an application or revoke an existing licence where an applicant is unable to meet the nationally recommended guidelines in respect of the listed medical conditions.
- 3a.67 If once licensed, the driver's medical circumstances change during the currency of the licence, the driver must inform the Council within 7 days. The Council may require the driver to immediately undertake a further medical examination and provide an approved medical report and certificate

confirming the outcome of this examination and the driver's fitness (or otherwise) to continue as a licensed driver. An applicant is responsible for paying the fee for any subsequent medical examinations.

- 3a.68 Should an authorised officer of the Council have reason to believe that a licensed hackney carriage or private hire vehicle driver has a medical condition that renders them unfit to drive, this includes but is not restricted to alcohol or drug misuse, a further independent medical examination will be requested, to a standard set by the Council, at a cost to the applicant.
- 3a.69 All medical examinations must be carried out by the applicant's registered General Practitioner (GP) or any registered GP/Medical Practitioner who confirms in writing that they have seen the applicant's medical records. The GP must be qualified and registered with the General Medical Council. The Council reserves the right to refer any medical matters to its own appointed Medical Officer who will review the medical fitness (or otherwise) of a driver to continue driving. The decision as to whether the driver can continue as a licensed driver will lie with an officer with delegated authority or the Licensing and Safety Sub-Committee (subject to the statutory right of appeal).
- 3a.70 The Council will not grant or renew, as the case may be, any driver's licence unless the foregoing provisions are complied with and the driver can demonstrate that they are medically fit to hold a drivers licence.
- 3a.71 With respect to current licence holders, if it is deemed necessary to do so, a licence may be revoked or suspended in the interests of protecting the public until further medical examination(s) has/have been carried out or if the licence holder is unable to demonstrate that they are medically fit to hold a drivers licence.

Medical exemption applications⁸

- 3a.72 Medical exemptions involving the carriage of disabled persons and assistance dogs may apply to new applicants or licensed drivers who suffer from certain medical conditions. Where this is the case, the applicant/licensed driver must apply for an exemption from the requirements under the Equality Act 2010.
- 3a.73 Applications for a medical exemption must be on the approved Shropshire Council medical exemption application form and must include sufficient proof that an applicant has a history of a specific medical problem(s) that meets the requirements for a medical exemption to be granted. The medical exemption application must be completed by an independent consultant or other specialist medical practitioner, who are not open to bias because of a commercial or personal connection to the applicant, who can provide up to date specialist medical information such as full diagnosis, details of ongoing investigations etc. and who can confirm in writing that they have seen the applicant's medical records. The consultant or specialist medical practitioner must be qualified and registered with the General Medical Council.
- 3a.74 The Council reserves the right to refer any medical matters to its own appointed Medical Officer who will review the medical fitness (or otherwise) of a driver to continue driving.
- 3a.75 The decision as to whether an exemption from the duties is granted will lie with an officer with delegated authority (at a meeting of the Licensing Panel) or the Licensing and Safety Sub-

⁸ <https://www.gov.uk/government/publications/access-to-taxis-and-private-hire-vehicles-for-disabled-users>

Committee (subject to the statutory right of appeal) who may resolve to grant the exemption for a limited or unlimited period or to refuse the exemption.

3a.76 The Council reserves the right to refuse to grant an exemption if sufficient medical proof is not provided and it is deemed appropriate to do so.

DVLA and other relevant driving licences

3a.77 A person applying for a drivers licence must have held a full DVLA category B or European Economic Area (EEA) driving licence or a driving licence as recognised by The Road Traffic Act 1988 (section 108) or The Driving Licence (Exchangeable Licences) Order 1999 for at least 3 years at the time of application. This includes Northern Ireland, Gibraltar, Andorra, Australia, Barbados, British Virgin Islands, Republic of Cyprus, The Falkland islands, The Faroe Islands, Guernsey, Hong Kong, Isle of Man, Japan, Jersey, Republic of Korea, Malta, Monaco, New Zealand, Singapore, Switzerland and Zimbabwe licences. The 3 year period is calculated from the date of issue of the full driving licence.

3a.78 Throughout the currency of the licence, the driver must possess a full driving licence in accordance with the above requirements.

3a.79 Applicants are required to produce the original of their driving licence. Copies will not be accepted. Where a driving licence has a photo card and counter-part paper licence, applicants must produce both parts and they must be of the same issue number.

3a.80 All applicants holding driving licences issued by agencies other than the DVLA must produce a certificate to show a driving record from the country of issue.

3a.81 As the Council is particularly concerned to ensure the safety of the travelling public, evidence that a full driving licence is held by an applicant or an existing licence holder in accordance with the above requirements is not necessarily sufficient evidence that a driver is a fit and proper person for the purposes of this Policy.

Working time directive

3a.82 Drivers are responsible for ensuring they do not work excessively long hours and put the safety of themselves and their passengers at risk. The Council strongly recommends that drivers monitor the hours worked and ensure adequate breaks and rest periods are taken. To this end, drivers must have regard to the European Union (EU) rules on driver hours and working time.

Disabled passengers: Duties of drivers

3a.83 Section 164A of the Equality Act 2010 imposes duties on the driver of a hackney carriage or private hire vehicle that has been hired by a disabled person or by another person who wishes to be accompanied by a disabled person, where:

- The hackney carriage or private hire vehicle is not included on a list of designated wheelchair accessible vehicles and where the passenger is disabled, including wheelchair users (with the assumption that the wheelchair user transfers to a passenger seat to travel)
- The hackney carriage or private hire vehicle is included on the list of designated wheelchair accessible vehicles and where the passenger is disabled but not in a wheelchair

3a.84 Section 166 of the Equality Act 2010 allows for drivers to apply for an exemption from the mobility assistance duties listed under section 164A of the Act on medical grounds or because the driver's physical condition makes it impossible or unreasonably difficult for them to comply with those duties. Further information can be found at paragraphs 3a.72 – 3a.76 of this section.

Disabled passengers: Assistance to identify and find vehicle

3a.85 Section 165A of the Equality Act 2010 imposes duties on the driver of a pre-booked hackney carriage or private hire vehicle that has been hired by or for a disabled person or by another person who wishes to be accompanied by a disabled person, where:

- The driver has been made aware before the start of the journey that the passenger requires assistance to identify or find their vehicle.

Disabled passengers in wheelchairs: Duties of drivers of designated wheelchair accessible vehicles

3a.86 Section 165 of the Equality Act 2010 imposes legal duties on the driver of a designated hackney carriage and private hire vehicle, which has been hired by or for a disabled person in a wheelchair, or by another person who wishes to be accompanied by a disabled person who is in a wheelchair.

3a.87 Section 166 of the Equality Act 2010 allows for drivers to apply for an exemption from the mobility assistance duties listed under section 165 of the Act on medical grounds or because the driver's physical condition makes it impossible or unreasonably difficult for them to comply with those duties. Further information can be found at paragraphs 3a.72 – 3a.76 of this section.

List of designated wheelchair accessible vehicles

3a.88 Section 167 of the Equality Act 2010 requires all local authorities to maintain a list of designated wheelchair accessible vehicles.

3a.89 All wheelchair accessible vehicles must be capable of transporting the user of a "reference wheelchair" and will be included within the Council's list of designated vehicles. Specifications for a "reference wheelchair" can be found at **Appendix J**.

3a.90 Proprietors have a responsibility to ensure that any Shropshire Council licensed driver who drives one of their wheelchair accessible vehicles is made aware of their duties in respect of carrying disabled persons in wheelchairs when driving a designated wheelchair accessible vehicle.

3a.91 Failure to comply with the duties listed under section 165 of the Equality Act 2010 is a criminal offence.

Production of records/documents

3a.92 Any records required to be retained in accordance with the licence and licence conditions must be produced, on request, to any authorised officer of the Council or to any police officer.

Licence conditions

3a.93 The applicable conditions with which a driver holding a hackney carriage or private hire drivers licence must comply are set out at **Appendix B**. These conditions are in addition to any matters prescribed by statute, byelaws and set out within the main body of the Policy.

Main legal requirements

3a.94 Paragraphs 3a.95 to 3a.110 is not exhaustive and unless otherwise specified please refer to the Town Police Clauses Act 1847 and the Local Government (Miscellaneous Provisions) Act 1976 for a full list of legal requirements, offences and the maximum penalty upon conviction.

3a.95 Production of documents

The driver must, on request, produce for inspection their driver's licence forthwith or within 5 days to either the Council's offices or a police station.

3a.96 Driver's badges and licences

The badge must be worn by the driver at all times when driving the licensed vehicle and the badge must be plainly and distinctly visible. This includes the requirement to display the duplicate driver's badge on the inside of the windscreen of the vehicle so as to be plainly visible at all times to fare paying passengers.

3a.97 All drivers of vehicles licensed for hackney purposes of which they are not the proprietor, must before commencing driving that vehicle, deposit a copy of their paper driver's licence with the proprietor for retention by him until such time as the driver ceases to be permitted or employed to drive the vehicle or any other vehicle of his.

3a.98 On ceasing to be a licensed driver through suspension, revocation, refusal to renew or expiry of the driver's licence, the licence holder must return the badge and licence to the Council within 7 days (or earlier if the Council so demands) of the suspension, revocation, refusal to renew or expiry becoming effective.

3a.99 Journeys

Drivers must not unnecessarily prolong a journey, in distance or in time.

3a.100 Vehicles permitted to be driven for private hire and hackney carriage purposes

Only vehicles licensed by the Council are permitted to be used for hackney carriage and private hire purposes, as specified by the Council's vehicle licence.

3a.101 Driving licensed vehicles

Only drivers who are licensed by the Council that licensed the vehicle are permitted to drive the licensed vehicle. The only exceptions to this are when the vehicle is undergoing an MOT test and needs to be driven by the MOT examiner or it is being driven by a vehicle tester⁹ for the purposes of a vehicle service, recovery or maintenance or otherwise permitted by legislation.

3a.102 Touting

A proprietor or driver of a hackney carriage, when standing or plying for hire, must not call out or otherwise importune any person to hire such vehicle and must not make use of the services of any other person for this purpose. This is an offence under the Criminal Justice and Public Order Act 1994, section 167.

⁹ As defined in section 62 (1) of the Vehicle Excise and Registration Act 1994

3a.103 Plying for hire

Drivers of private hire vehicles must NOT ‘ply for hire’. The Council’s interpretation of ‘plying for hire’ is set out at **Appendix H** and is based on relevant legislation and case law.

3a.104 Transporting children

As a minimum, drivers must comply with the requirements set out in the table below, for further guidance see <https://www.gov.uk/child-car-seats-the-rules/when-a-child-can-travel-without-a-car-seat>.

	Front seat	Rear seat	Who is responsible?
Child up to 3 years	Correct child restraints must be used	Correct child restraint must be used. If a restraint is not available in a licensed hackney carriage or private hire vehicle, the child may travel unrestrained.	Driver**
Child from 3rd birthday up to 135 cm in height or 12th birthday, whichever they reach first	Correct child restraints must be used	Where seat belts are fitted, the correct child restraint must be used. The child must use adult belt if the correct child restraint is not available as follows: in a licensed hackney carriage or private hire vehicle; or for a short distance in an unexpected necessity; or two occupied child restraints prevent fitting of a third. A child 3 years and over may travel unrestrained in the rear seat of a vehicle if seat belts are not fitted in the rear.	Driver**
Child over 135 cm in height or 12 or 13 years old	Seat belt must be worn if available*	Seat belt must be worn if available.	Driver**
Passengers aged 14 years and over	Seat belt must be worn if available*	Seat belt must be worn if available.	Passenger

*Vehicles built before 1965 are not required to have fitted seatbelts.

**Drivers must inform parents/carers that the decision to permit children to travel in the vehicle, without the correctly sized seat restraints (as permitted by relevant legislation) and with the obvious risks associated with such an action, remains with the parent/carer responsible for the children and not with the driver of the vehicle.

3a.105 Smoking in vehicles

Drivers must not, at any time, smoke or permit passengers to smoke in their vehicle as required by the Health Act 2006 and the Smoke-Free (Exemptions and Vehicles) Regulations 2007 (this includes electronic cigarettes and vaping).

3a.106 Refusing to convey passengers

A driver of a hackney carriage who is waiting at a rank/stand must not refuse to carry a passenger without a reasonable excuse.

3a.107 Overcharging

Drivers of hackney carriages must not charge more than is permitted under the current table of fares. Drivers undertaking journeys ending outside the Council's area and in respect of which no fare and no rate of fare was agreed before the journey commenced must not charge more than that indicated on the taximeter or more than the current table of fares allows.

3a.108 Persons riding without consent

Drivers of hackney carriages must not permit persons to be carried in the vehicle unless they have the consent from the person who is actually hiring the vehicle.

3a.109 Unlicensed drivers

Licensed drivers of hackney carriages must not allow any persons to drive a hackney carriage unless they are authorised to do so by the proprietor and hold an appropriate licence to do so.

3a.110 Obstruction

Hackney carriage drivers must not obstruct other hackney carriage drivers/vehicles from undertaking their normal hiring and driving activities.

Summary

- 3b.1 Hackney carriages are licensed in accordance with the provisions contained in the Town Police Clauses Act 1847 and the Local Government (Miscellaneous Provisions) Act 1976.
- 3b.2 Commonly known as ‘taxis’, hackney carriages are licensed to stand for hire at a taxi rank or can be hailed in the street in the administrative area of the council with which it is licensed and may also undertake pre-booked journeys anywhere in the country.
- 3b.3 The Council does not limit the number of hackney carriage licences that it will issue.
- 3b.4 The Council will not licence a vehicle for hire and reward which is licensed by another local authority or allow or permit a hackney carriage identification plate issued by another authority to be displayed on the vehicle.
- 3b.5 All hackney carriages, whilst plying for hire, must be immediately capable of providing for at least one wheelchair.
- 3b.6 All hackney carriages are required to be wheelchair accessible and capable of transporting the user of a “reference wheelchair”. Specifications for a “reference wheelchair” can be found at **Appendix J**.

Intended use of vehicles

- 3b.7 The Council operates an ‘Intended Use and Licensing of Hackney Carriages Policy’. All applicants are required to pay particular attention to this policy, in particular if your address falls outside the administrative area of Shropshire Council; full details are set out at **Appendix K**.

Applicant

- 3b.8 The applicant for a vehicle licence must be the person who is the legal owner of the vehicle concerned and entitled to have ownership of the vehicle¹⁰.

Fit and proper person

- 3b.9 The proprietor of a licensed hackney carriage provides a public service that impacts on public safety. On this basis, the Council will not licence a vehicle as a hackney carriage unless it is satisfied that the proprietor of the vehicle meets all the criteria to be deemed a fit and proper person as set out in **Appendix I**.

Proprietors who apply for a hackney carriage licence and who hold a valid Shropshire Council hackney carriage/private hire drivers licence or a valid Shropshire Council private hire operator licence

- 3b.10 The Council adopts the same principles when determining whether an applicant is a fit and proper person to hold a vehicle licence as it does to persons applying for a drivers licence. In this respect,

¹⁰ There is no legal definition of proprietor within relevant legislation; however, the Council has taken the view that proprietor means the legal owner based on common usage of the term.

applicants are required to have due regard, as appropriate, to the requirements and information set out at paragraphs 3a.4 to 3a.24 of the Policy.

Proprietors who apply for a hackney carriage licence and who do not hold a valid Shropshire Council hackney carriage/private hire drivers licence or a valid Shropshire Council private hire operator licence

- 3b.11 In considering the fit and proper person test, all applicants on initial application must provide a basic criminal record disclosure from the Disclosure and Barring Service. All applicants on renewal must provide a basic criminal record disclosure that has been issued by the Disclosure and Barring Service within the previous 12 months of the date that the application is received by the Council. On new and renewal applications the Council will also make additional enquiries through its adults and childrens social care teams, directly with West Mercia Police (and other relevant police forces, where appropriate), other relevant local authorities (particularly Telford & Wrekin Council and City of Wolverhampton Council) and any other appropriate organisation, agency or person in order to ensure the Council is in a position to make as accurate an assessment of the applicant's fitness to hold a licence as is reasonably practicable.
- 3b.12 With specific reference to existing licence holders, where there is any cause for a licence to be reviewed, the Council will make additional enquiries through its adults and childrens social care teams, directly with West Mercia Police (and other relevant police forces, where appropriate), other relevant local authorities (particularly Telford & Wrekin Council and City of Wolverhampton Council) and any other appropriate organisation, agency or person in order to ensure the Council is in a position to make as accurate an assessment of the licence holders fitness to hold a licence as is reasonably practicable. Depending on the circumstances of the case, the Council may request the licence holder to consent to a further basic criminal record disclosure, the cost of which lies with the licence holder. Where a licence holder refuses to consent to a further check the Council will take this into consideration in determining their continuing fitness to hold a licence.
- 3b.13 When assessing the fitness of an applicant to hold a hackney carriage proprietors licence, the Council will consider the applicant's criminal history as a whole, together with all other relevant evidence, information and intelligence including their history (e.g. complaints and positive comments from the public, compliance with licence conditions and willingness to co-operate with licensing officers) whilst holding a licence from the Council or any other authority. Particular attention will be given to patterns of behaviour, irrespective of the time-scale over which they have occurred, both in terms of proven criminal offences and other behaviour/conduct that may indicate the safety and welfare of the public may be at risk from the applicant.
- 3b.14 In addition, an important element associated with the fitness to hold a licence is the appearance and behaviour of an applicant. Consequently, the Council requires all applicants to maintain a reasonable standard of appearance and behaviour when in contact and dealing with all persons, including but not limited to, other road users, pedestrians, customers, the general public, other licensed operators and drivers of hackney carriage and private hire vehicles, Council officers and elected members at all times. Applicants must also co-operate with any reasonable request made by an authorised officer of the Council or any police officer.
- 3b.15 It must also be recognised that the Council will consider all relevant criminal history, behaviour and conduct irrespective of whether the specific history, behaviour or conduct occurred whilst applicants were directly engaged in hackney carriage or private hire licensed work at the time or whether they occurred during the applicants' own personal time. The Council considers a person or individual who has a propensity to commit offences and/or demonstrate unacceptable conduct

whilst not engaged in hackney carriage or private hire work to be equally as serious as offences and/or unacceptable conduct committed whilst engaged in hackney carriage or private hire work.

Criminal record disclosure

- 3b.16 All unspent convictions, including cautions, will be taken into account when considering a person's suitability to hold a licence. Consequently, applicants are required to provide details of all unspent convictions and cautions, including driving endorsements (driving convictions) and disqualification periods relating to traffic offences.
- 3b.17 Although cautions are generally not as serious as convictions, ordinarily as a result of the circumstances under which they are offered, they do require an admission of guilt before they can be issued which is equivalent to a guilty plea on prosecution. Consequently, a caution is regarded in exactly the same way as a conviction. Fixed penalties, community resolutions or similar sanctions will also be considered in the same way as a conviction on the basis that payment of a fixed penalty indicated an acceptance of guilt and a community resolution can only be imposed following an admission of guilt. As a result, each of these sanctions is a valuable indication as to an applicant's character and whether they are a fit and proper person to hold or be granted a licence.
- 3b.18 A criminal record does not automatically bar an applicant from holding a licence; however, it will be a significant factor when determining whether a licence ought to be granted or not. Where an applicant has previous criminal convictions, these will be considered in line with the guidance set out in **Appendix I**. However, the over-riding consideration will always be to ensure the safety and welfare of the public.
- 3b.19 Persons who have not been resident within the United Kingdom for the five years prior to submitting an application, will be required to produce a certificate of good conduct or equivalent document (at their own cost) issued by the relevant Embassy or High Commission. The certificate must be authenticated, translated and sealed by the Embassy or High Commission. In the event that an applicant is not able to obtain a certificate of good conduct, they may submit a statutory declaration with regard to their conduct, which must be completed in the presence of a practising solicitor. The Council may contact the relevant Embassy, High Commission, solicitor or other appropriate body to verify any documents provided. Contact details for Embassies and High Commissions can be found from the Foreign, Commonwealth & Development Office (FCDO) on the GOV.UK website at <https://www.gov.uk/government/world>. The FCDO may be contacted for further assistance by telephone on 020 7008 5000, by email at fcdo.correspondence@fcdo.gov.uk or by post at the FCDO, King Charles Street, London, SW1A 2AH.
- 3b.20 Applicants who have spent three continuous months or more living outside the United Kingdom, during the period of their licence, will be required to produce a certificate of good conduct or equivalent document at their own cost. This certificate must be issued by the relevant Embassy or High Commission for the country or countries lived in during this period and meet the requirements as set out at 3b.19 above. It is recognised that some countries will not provide a certificate of good conduct unless the individual has been resident for six months or more. Where a relevant Embassy or High Commission refuse to issue a certificate of good conduct, applicants must provide written confirmation from the Embassy of any refusal to the Licensing Team.

Non-conviction information

- 3b.21 In addition to conviction/caution information, applicants are expected to provide details, within 48 hours of all warnings, driving endorsements (driving convictions)/disqualification periods relating to traffic offences, fixed penalties, community resolutions and any other similar sanctions, together with any charges or arrests that they are the subject of in connection with criminal offences, whether or not actually charged with the offence, and details of any allegations of involvement in criminal activity or where they have been questioned in connection with any alleged criminal activity or inappropriate/unacceptable behaviour or any other relevant pending matter.
- 3b.22 Where an applicant is the subject of an outstanding charge or summons, their application may continue to be processed; however, depending on the circumstances, it is unlikely that a decision on the application will be made until the conclusion of the criminal proceedings. Where the outstanding charge or summons involves a serious offence and/or the individual's offending history and behaviour/conduct indicates a pattern of unlawful or unacceptable behaviour/character traits, then the application is likely to be refused.
- 3b.23 Where there is evidence/information that an applicant has been arrested or charged but not convicted of offences and the nature of this evidence/information suggests the applicant may not be a fit and proper person, the Council will give serious consideration to refusing an application or revoking an existing licence.

Period of licence

- 3b.24 Vehicle licences will be issued for a maximum period of 12 months.

Vehicle licence plates

- 3b.25 The external plates (front and rear) and the internal plate, identifying the vehicle as a hackney carriage, show the licence details on a white background with the Shropshire Council logo.

Vehicle specifications

- 3b.26 The Council requires all hackney carriage vehicles to comply with the following requirements:

Emissions/Age Restrictions*

- 3b.27 Wheelchair accessible vehicles must comply with the following:

Renewal/New Application	Fuel	Period	European Emission/Age Standard
New	Petrol	1 April 2023 to 31 March 2024	Euro 5
New	Petrol	1 April 2024 to 31 March 2028	Euro 5 and where the vehicle is less than 12 years old from date of first registration

New	Diesel	1 April 2023 to 31 August 2025	Euro 6/Euro 6d and where date of first registration is on or after 1 September 2016
New	Diesel	1 September 2025 to 31 March 2028	Euro 6 / Euro 6d and where the vehicle is less than 6 years old from date of first registration
New	Full electric	1 April 2023 to 31 March 2028	Any age
New	Hybrid petrol	1 April 2023 to 31 March 2028	Less than 12 years old from date of first registration
New	Hybrid diesel	1 April 2023 to 31 March 2028	Less than 10 years old from date of first registration
New	LPG	1 April 2023 to 31 March 2028	Less than 12 years old from date of first registration
Renewal	Petrol	1 April 2023 to 31 March 2024	Euro 5
Renewal	Petrol	1 April 2024 to 31 March 2028	Euro 5 and where the vehicle is less than 15 years old from date of first registration
Renewal	Diesel	1 April 2023 to 31 March 2025	Euro 5 / Euro 6 / Euro 6d and where the vehicle is less than 12 years old from date of first registration
Renewal	Diesel	1 April 2025 to 31 March 2028	Euro 6 / Euro 6d and where the vehicle is less than 12 years old from date of first registration
Renewal	Full electric	1 April 2023 to 31 March 2028	Any age
Renewal	Hybrid petrol	1 April 2023 to 31 March 2028	Less than 15 years old from date of first registration
Renewal	Hybrid diesel	1 April 2023 to 31 March 2028	Less than 12 years old from date of first registration

Renewal	LPG	1 April 2023 to 31 March 2028	Less than 15 years old from date of first registration
---------	-----	-------------------------------	--

* For whatever reason, legal or otherwise, an applicant is not required to licence a wheelchair accessible vehicle, the age/emissions restrictions as set out at Part 3c, Standard Private Hire Vehicles, paragraph 3c.26 will apply.

NB The chart above provides information for the licensing of vehicles up to 31 March 2028 and the maximum age for a vehicle to remain licensed. The Council does not currently intend to make any changes in the future to reduce the maximum age for a vehicle to remain licensed where a vehicle had already been licensed before 31 March 2028. However, the Policy will be subject to continuous evaluation and, if necessary, can be formally reviewed at any time.

Safety

- 3b.28 The Council will not licence any new vehicle that since the date of first registration has been recorded by the DVLA as having sustained structural damage resulting from a road traffic accident (an insurance 'Write Off' under the DVLA's Category S – Structural damage classification for vehicle that has sustained damage after 1 October 2017 or Category C where a vehicle has sustained damage, rendering it beyond economical repair, prior to 1 October 2017). This information can be found in Part 3 – Special Notes of the V5 Registration Certificate.
- 3b.29 Hackney carriages that have been specifically constructed or adapted for disability access and any M1 (not M2 or N1) vehicles that have been adapted to be a hackney carriage must provide one of the following documents in order to demonstrate that the vehicle has been converted to an acceptable standard:
- Where the vehicle has come off the production line as a purpose-built wheelchair accessible vehicle there will be a Vehicle Certification Agency (VCA) certificate, which demonstrates that the vehicle has been constructed to an acceptable safety standard, providing there have been no changes to the layout of the vehicle since the VCA was issued.
 - Where the vehicle is modified after production, but before first registration, there may be an Individual Approval Certificate (IAC) available, which will demonstrate that the adaptations have been tested by DVSA (VOSA) and are to an acceptable safety standard, providing there have been no changes to the conversion since the IAC was issued. This may be referred to as a Statutory Individual Vehicle Approval.
 - Vehicles that are converted for disability access after first registration must be submitted for a Basic Voluntary IVA (Individual Vehicle Approval). This is the route that vehicles are required to take where there is no VCA certificate or IAC available. Vehicles must be presented to the DVSA for a Basic Voluntary IVA inspection Class P – Personal Import. If the vehicle passes the inspection it will receive a Certificate of Compliance (IVA 6). The Voluntary IVA checks the whole of the vehicle, not only the parts that have been converted and is similar to a very strict MOT test.
- 3b.30 Where a proprietor has notified the Council that a licensed vehicle has sustained structural damage from a road traffic accident resulting in a DVLA classification under Category S – Structural damage (vehicle that has sustained damage after 1 October 2017) or Category C (vehicle has sustained damage, rendering it beyond economical repair, prior to 1 October 2017), any documents provided to meet the safety requirements of the policy as part of the previous application process (i.e. IVA certificate) will be invalid. The proprietor will be required to submit the vehicle for a new voluntary IVA check and provide a valid IVA certificate to the Licensing Team.

List of Designated Wheelchair Accessible Vehicles

- 3b.31 Section 167 of the Equality Act 2010 requires all local authorities to maintain a list of designated wheelchair accessible vehicles.
- 3b.32 All wheelchair accessible vehicles must be capable of transporting the user of a “reference wheelchair” and will be included within the Council’s list of designated vehicles. Specifications for a “reference wheelchair” can be found at **Appendix J**.
- 3b.33 Section 172 of the Equality Act 2010 provides for an appeal to be made against the decision to include a vehicle on the list of designated wheelchair accessible vehicles. Any appeal must be made to the Magistrates Court within 28 days of the vehicle being included on the list.
- 3b.34 Proprietors have a responsibility to ensure that any Shropshire Council licensed driver who drives one of their wheelchair accessible vehicles is made aware of their duties in respect of carrying disabled persons in wheelchairs when driving a designated wheelchair accessible vehicle.
- 3b.35 Failure to comply with the duties listed under section 165 of the Equality Act 2010 is a criminal offence.

Other Requirements

- 3b.36 Vehicles must not seat more than eight passengers (not including the driver) and:
- (a) Be a Light Passenger Vehicle as defined by section 85 of the Road Traffic Act 1988 and have a minimum of 4 wheels
 - (b) Provide sufficient means by which any person in the carriage may communicate with the driver
 - (c) Proprietors are encouraged to consider only using vehicles where the entire external bodywork of the vehicle is of a uniform black colour. This does not prohibit the display of advertisements, information, images or other material as authorised by the Council
 - (d) All paintwork must be maintained in a uniform colour (but note ‘c’ above) and free from dents, scratches or rust
 - (e) Have a watertight roof or covering
 - (f) Provide at least two windows on each side of the vehicle of which one window on one side must have a means of opening/closing
 - (g) Tinted windows will only be permitted in accordance with the manufacturers or specialist coachbuilder’s specification and must comply with the Road Vehicles (Construction & Use) Regulations 1986. The Council will not permit any form of additional film to darken or tint the glass on any part of the vehicle
 - (h) Have seats that are properly cushioned and covered
 - (i) Have a floor provided with a proper carpet, mat, or other suitable covering
 - (j) Have fittings (including fittings that are used to secure wheelchairs to the floor of the vehicle) and furniture in a clean condition and be well maintained and in every way fit for public service
 - (k) Provide means for securing luggage if the carriage is so constructed as to carry luggage
 - (l) Where tilting passenger seats are fitted the seat must:
 - Be forward facing (with the exception of the fold down seats fitted onto the bulkhead/partition of a purpose-built hackney carriage)
 - Be designed for use by an adult

- Have a three point seatbelt
As specified in the Road Vehicle (Construction and Use) Regulations 1986 (as amended)
- (m) Have a minimum of four passenger doors including an entry/exit point for the driver if a vehicle other than a purpose-built hackney carriage
- (n) Be maintained in a sound mechanical and structural condition at all times
- (o) Have a full size spare wheel or space saver design wheel and the tools to change a wheel OR a contract with a mobile tyre replacement specialist (in any event where a spare wheel has been used, it is only to permit the current fare to be completed and any defective wheel must be replaced before taking another fare to ensure passenger safety); all pneumatic tyres, including the spare, must comply with the vehicle manufacturer's specification and any relevant legislation
- (p) Be maintained in a clean and safe condition at all times from both exterior and interior perspectives
- (q) Have provision for the legal transportation of a minimum of one "reference wheelchair" at all times. Specifications for a "reference wheelchair" can be found at **Appendix J**
- (r) Where a mechanical ramp is fitted, comply with requirements of the Lifting Operations and Lifting Equipment Regulations 1998
- (s) Where a non mechanical ramp is fitted, comply with the relevant provisions of the Provision and Use of Work Equipment Regulations 1998
- (t) When transporting a wheelchair user, where a seat has to be removed in order to accommodate a passenger in a wheelchair, proprietors must store the seat securely away from the passengers and driver (e.g. in the boot)
- (u) When transporting a wheelchair user, where the wheelchair user chooses to transfer to a passenger seat, proprietors must store the wheelchair securely away from the passengers and driver (e.g. in the boot)

New application process

- 3b.37 The application form must be fully completed and include all relevant information, supporting documentation and appropriate fee.
- 3b.38 The full fee for the licence is payable at the time the application is submitted (this includes any application to transfer a vehicle licence onto another vehicle).
- 3b.39 If any part of the application form is incomplete or the relevant information or supporting documentation is not provided, the applicant will be requested to provide the missing information/documentation and informed that the application will not be processed until such time as all the information/documentation is provided. If the applicant fails to provide all the information to complete the application, the application will be rejected.
- 3b.40 Once an application has been accepted by the Licensing Team as a valid application the application process must be completed within 6 months unless prevented from doing so by matters that are outside the applicant's control. Where an application is not completed within this timescale the application will be referred to the Licensing Panel for determination where an officer with delegated authority will consider each case on its own individual merits and will determine what action is appropriate and proportionate to the circumstances of the case.
- 3b.41 Any person wishing to licence a hackney carriage vehicle must:
- Submit a completed application form

- Submit a completed reference form unless the applicant is the holder of a hackney carriage and private hire drivers licence or private hire operator licence issued by Shropshire Council (NB the referees must be from either professional or business sources who have known the applicant for at least two years. In addition, the Council will not accept references from family members, drivers, operators, vehicle proprietors licensed with any local authority or, where relevant, the applicant's future employer unless there is satisfactory evidence of exceptional circumstances that are accepted by the Council). The Council reserves the right to refuse a reference where the Council deems the referee is not acceptable
- Pay the appropriate licence fee
- Provide a basic criminal record disclosure from the Disclosure and Barring Service, unless the applicant is the holder of a hackney carriage and private hire drivers licence or private hire operator licence issued by Shropshire Council (applicants can apply to <https://www.gov.uk/request-copy-criminal-record>). A basic criminal record disclosure will only be accepted by the Council within 12 months of the date of issue from the Disclosure and Barring Service
- Provide a valid MOT (in accordance with the requirements set out at paragraph 3b.49 below)
- Provide a valid certificate of insurance for public hire, including proof of Public Liability insurance for a minimum of £5,000,000, in accordance with the requirements set out at paragraph 3b.53 below
- Provide the full V5 registration certificate (note the alternative interim measures outlined in paragraphs 3b.55 to 3b.58)
- Provide a valid certificate/report to confirm the vehicle is fitted with a taximeter in accordance with the requirements set out at paragraph 3b.47 below
- Evidence of compliance with the relevant European Emission/Age Standards as set out in paragraph 3b.27 either at the point of vehicle construction or by a subsequent adaption or conversion approved by the Council - the compliance must be relevant to the engine installed in the vehicle and this must be reflected in the V5 registration certificate
- Provide evidence of safety compliance as set out in paragraphs 3b.29 to 3b.30
- Where the vehicle is fitted with a mechanically operated ramp, provide a valid certificate/report confirming the ramp complies with the requirements of the Lifting Operations and Lifting Equipment Regulations 1998 (NB The proprietor is responsible for ensuring that a competent person carries out the necessary checks in accordance with these Regulations)
- Where non-mechanical ramps are used, provide confirmation from the proprietor of the vehicle that the ramps comply with the relevant provisions of the Provision and Use of Work Equipment Regulations 1998 (NB Licensing officers will check that the provision of non-mechanical ramps is being maintained by the vehicle proprietor)
- Where fittings are used to secure wheelchairs to the floor of a vehicle, provide a certificate/report confirming that all the fittings are intact and are free from damage and wear

3b.42 Once an application has been validated and accepted, the Council will:

- Make enquiries through the Councils adults and childrens social care teams, West Mercia Police (or other relevant force), other local authorities and any other organisation, agency or person that the Council has deemed appropriate to seek information from
- Where applicable, write to the referees provided

- 3b.43 **NB** For partnerships or companies, the requirements set out in paragraphs 3b.8 to 3b.23 apply to all partners and directors/company secretaries.
- 3b.44 Where an application is received to change the proprietor of a hackney carriage vehicle licence (transfer of licensee), the new proprietor must fulfil the requirements as set out in paragraphs 3b.8 to 3b.23.
- 3b.45 Paragraphs 3b.8 to 3b.23 do not apply to applications to transfer a vehicle licence onto another vehicle, on a temporary basis, by an accident management company.
- 3b.46 Providing the above are satisfied, Officers will grant the licence. In all other cases, the application will be referred to the Licensing Panel for determination. Each application will be decided on its merits. However, there is a presumption that unless an applicant can demonstrate exceptional circumstances the application will be refused. Whilst it is neither possible nor prudent to draw up a list of what might amount to exceptional circumstances, an applicant who claims that exceptional circumstances exist will be expected to be able to satisfy the Council that it would not frustrate the purposes of this Policy or compromise public safety if the licence were granted. The applicant will be notified in writing if their application is to be determined at a meeting of the Licensing Panel.

Taximeters

3b.47 Taximeters must:

- Be certified by a notified body in accordance with the Measuring Instruments Directive (MID) (2004/22/EC), in particular Annex 007
- Be fitted with a device, the use/action of which will bring the taximeter into action and cause the word 'HIRED' to appear on the face of the taximeter and such a device must be capable of being locked in a position such that the machinery of the taximeter is not in action and that no fare is recorded on the face of the taximeter
- Be calibrated to ensure the tariff charged does not exceed the maximum fares determined by the Council
- Be calendar controlled
- Be fixed to the vehicle with appropriate seals/appliances to prevent any person from tampering with the meter except by breaking, damaging, or permanently displacing the seals/appliances
- Have the word 'FARE' printed on the face of the meter in plain letters so as clearly to apply to the fare recorded thereon, and
- Be supported by a Shropshire Council certificate/report of compliance (the Council will only accept a certificate that has been issued within the previous 10 working days)

3b.48 With respect to a licensed vehicle, in the event that a proprietor fails to present to the Council a valid certificate/report of compliance (unless delayed or prevented by sufficient cause accepted and agreed by the Council), the Council may suspend the licence and require the proprietor of that hackney carriage to return all the plates to the Council subject to any appeal period.

MOT requirements¹¹

3b.49 MOTs are required in accordance with the following requirements:

¹¹ The requirement to submit an MOT will be in accordance with section 50 of the Local Government (Miscellaneous Provisions) Act 1976

- Vehicles, up to 9 years from date of first registration, must be submitted for an MOT inspection at 6-monthly intervals (and any other inspection deemed necessary by an authorised officer) and the applicant must produce valid MOT certificates to the Council in this respect.
- Once a vehicle reaches the age of 9 years, in addition to the MOT certificate submitted with an application, it must have two other MOT tests per year; tests being spaced evenly throughout the year at four monthly intervals and the applicant must produce valid MOT certificates to the Council in this respect.
- MOT certificates will only be accepted by the Council within 10 working days of the date of issue from the MOT testing centre.
- MOTs must be undertaken by a 'Nominated Tester' or Authorised Vehicle Examiner at a Vehicle Testing Station appointed under Section 45 of The Road Traffic Act 1988; the cost of all tests must be met by the vehicle proprietor.
- The vehicle must have a valid MOT throughout the licence period.

3b.50 With respect to a licensed vehicle, in the event that a proprietor fails to present to the Council an MOT test certificate as required (unless delayed or prevented by sufficient cause accepted and agreed by the Council), the Council may suspend the licence and require the proprietor of that hackney carriage to return all the plates to the Council subject to any appeal period.

MOT failures and advisories

3b.51 The Council's position in regards to MOT failures and advisories is as follows:

- Where a vehicle fails an MOT under the category dangerous (do not drive until repaired) defects, DVSA guidance states that this will have a direct and immediate risk which will put passengers and other road users at risk or have a serious impact on the environment. The Council requires all repairs to be undertaken and a new MOT test certificate issued before the vehicle is used as a hackney carriage.
- Where a vehicle fails an MOT under the category major (repair immediately) defects, the Council has a concern for the vehicle safety which may put passengers and other road users at risk or have an impact on the environment. The Council requires all repairs to be undertaken and a new MOT test certificate issued before the vehicle is used as a hackney carriage.

3b.52 Shropshire Council reserves the right to require proprietors to rectify any items listed under minor or advisory information on an MOT certificate and to provide evidence that the work has been completed to the Council within a timescale specified by the Council. In the event that a proprietor fails to rectify any items requested by the Council (unless delayed or prevented by sufficient cause accepted and agreed by the Council), the Council may suspend the licence and require the proprietor of that hackney carriage to return all the plates to the Council subject to any appeal period.

Insurance

3b.53 Certificates of insurance are required in accordance with the following requirements:

- The vehicle must have a valid certificate of insurance for public hire, including proof of Public Liability insurance for a minimum of £5,000,000, throughout the licence period.

- Certificates of insurance or cover notes issued to cover “any vehicle” or “any driver” must be accompanied by a schedule showing all the vehicles and drivers covered by the insurance as detailed in the certificate of insurance.
- Where a vehicle is insured by a proprietor and the proprietor allows another licensed Shropshire Council driver to drive their vehicle, or any vehicle is insured under a fleet insurance, the proprietor (as the policy holder) is responsible for ensuring that the driver of that vehicle is aware of the content of the policy, including its limitations and exclusions, and that the proprietor keeps records to this effect.
- Where an insurance cover note is provided a full certificate of insurance must be produced to the Council within 7 days of the certificate being received by the owner of the vehicle.
- The proprietor must also obtain information as to any requirement for them to have Employers Liability Indemnity; if there is such a requirement, it must be for a minimum of £1,000,000.

3b.54 With respect to a licensed vehicle, in the event that a proprietor fails to present to the Council a valid certificate of insurance as required (unless delayed or prevented by sufficient cause accepted and agreed by the Council), the Council may suspend the licence and require the proprietor of that hackney carriage to return all the plates to the Council subject to any appeal period.

V5 registration certificate

3b.55 The Council accepts that a full V5 registration certificate in the new owner’s name is not always available upon first licence or as part of an application to transfer the licensee; however, the green new keepers slip of the V5 form and proof of purchase must be produced. Where possible a full copy of the previous owners V5 registration certificate should be obtained and submitted alongside the green new keeper slip.

3b.56 A full V5 registration certificate and proof of purchase must be produced upon transfer of a vehicle licence. Where possible a full copy of the previous owners V5 registration certificate should be obtained and submitted alongside the V5 green section.

3b.57 Where the green section has been produced on first licensing the vehicle or as part of an application to transfer the licensee, a full V5 registration certificate in the new owner’s name must be produced to the Council within 7 days of the form being received by the owner of the vehicle.

3b.58 Where a licence is issued in advance of a full V5 registration certificate being received and where upon receipt of a full V5 registration certificate information is contained that indicates that a vehicle has, since the date of first registration, been recorded by the DVLA as having sustained structural damage resulting from a road traffic accident, as set out in paragraph 3b.28, the licence will be subject to review at a meeting of the Councils Licensing Panel.

Renewal of a licence

3b.59 To allow the vehicle’s licence to be renewed, a renewal application form must be received by the Council at least 10 working days prior to the expiry date of the original licence (unless there is satisfactory evidence of exceptional circumstances that are accepted by the Council) to allow the Council sufficient time to process the renewal application. It is the Council’s intention to process all valid renewal applications within 10 working days; hence, where applicants fail to submit their renewal application within this timescale, the risk that their licence will expire increases. Once a licence expires, is revoked (subject to a statutory appeal process) or surrendered, it ceases to exist

and applicants would not be permitted to drive the hackney carriage vehicle in these circumstances.

3b.60 Once a licence ceases to exist a renewal application will not be accepted by the Council (unless there is satisfactory evidence of exceptional circumstances that are accepted by the Council) and the applicant must submit a new vehicle licence application which will be processed in accordance with the Council's new application process.

Renewal application process

3b.61 The application form must be fully completed and include all relevant information, supporting documentation and appropriate fee.

3b.62 The full fee for the licence is payable at the time the application is submitted. (This includes any application to transfer a vehicle licence onto another vehicle)

3b.63 If any part of the application form is incomplete or the relevant information or supporting documentation is not provided, the applicant will be requested to provide the missing information/documentation and informed that the application will not be processed until such time as all the information/documentation is provided. If the applicant fails to provide all the information to complete the application, the application will be rejected.

3b.64 Once an application has been accepted by the Licensing Team as a valid application the application process must be completed within 6 months unless prevented from doing so by matters that are outside the applicant's control. When an application is not completed within this timescale the application will be referred to the Licensing Panel for determination where an officer with delegated authority will consider each case on its own individual merits and will determine what action is appropriate and proportionate to the circumstances of the case.

3b.65 Any person wishing to renew a licence for a hackney carriage vehicle must:

- Submit completed application form
- Pay the appropriate licence fee
- Provide a basic criminal record disclosure from the Disclosure and Barring Service, unless the applicant is the holder of a hackney carriage and private hire drivers licence issued by Shropshire Council (applicants can apply to <https://www.gov.uk/request-copy-criminal-record>). A basic criminal record disclosure will only be accepted by the Council within 12 months of the date of issue from the Disclosure and Barring Service
- Provide a valid MOT (in accordance with the requirements set out at paragraph 3b.70 below)
- Provide a valid certificate of insurance for public hire, including proof of Public Liability insurance for a minimum of £5,000,000, in accordance with the requirements set out at paragraph 3b.76 below
- Where the vehicle is fitted with a mechanically operated ramp, provide a valid certificate/report confirming the ramp complies with the requirements of the Lifting Operations and Lifting Equipment Regulations 1998 (NB The proprietor is responsible for ensuring that a competent person carries out the necessary checks in accordance with these Regulations.)
- Where non-mechanical ramps are used, provide confirmation from the proprietor of the vehicle that the ramps comply with the relevant provisions of the Provision and Use of

Work Equipment Regulations 1998. (NB Licensing officers will check that the provision of non-mechanical ramps is being maintained by the vehicle proprietor.), and

- Where fittings are used to secure wheelchairs to the floor of a vehicle, provide a certificate/report confirming that all the fittings are intact and are free from damage and wear

3b.66 Once an application has been validated and accepted, the Council will

- Complete an online check of the MOT history for the vehicle
- Where applicable, make enquiries through the Councils adults and childrens social care teams, West Mercia Police (or other relevant force), other local authorities and any other organisation, agency or person that the Council has deemed appropriate to seek information from

3b.67 **NB** For partnerships or companies, the requirements set out in paragraphs 3b.8 to 3b.23 apply to all partners and directors/company secretaries.

3b.68 Where an application is received to change the proprietor of a hackney carriage vehicle licence (transfer of licensee), the new proprietor must fulfil the requirements as set out in paragraphs 3b.8 to 3b.23 above.

3b.69 Providing the above are satisfied, Officers will grant the licence. In all other cases, the application will be referred to the Licensing Panel for determination. Each application will be decided on its merits. However, there is a presumption that unless an applicant can demonstrate exceptional circumstances the application will be refused. Whilst it is neither possible nor prudent to draw up a list of what might amount to exceptional circumstances, an applicant who claims that exceptional circumstances exist will be expected to be able to satisfy the Council that it would not frustrate the purposes of this Policy or compromise public safety if the licence were granted. The applicant will be notified in writing if their application is to be determined at a meeting of the Licensing Panel.

MOT requirements¹²

3b.70 MOTs are required in accordance with the following requirements:

- Vehicles, up to 9 years from date of first registration, must be submitted for an MOT inspection at 6-monthly intervals (and any other inspection deemed necessary by an authorised officer) and the applicant must produce valid MOT certificates to the Council in this respect.
- Once a vehicle reaches the age of 9 years, in addition to the MOT certificate submitted with an application, it must have two other MOT tests per year; tests being spaced evenly throughout the year at four monthly intervals and the applicant must produce valid MOT certificates to the Council in this respect.
- MOT certificates will only be accepted by the Council within 10 working days of the date of issue from the MOT testing centre.
- MOTs must be undertaken by a 'Nominated Tester' or Authorised Vehicle Examiner at a Vehicle Testing Station appointed under Section 45 of The Road Traffic Act 1988; the cost of all tests must be met by the vehicle proprietor.
- The vehicle must have a valid MOT throughout the licence period.

¹² The requirement to submit an MOT will be in accordance with section 50 of the Local Government (Miscellaneous Provisions) Act 1976

- 3b.71 The Council will check the MOT history of a licensed vehicle to ensure that the vehicle has not been used to fulfil any hackney carriage work on a failed MOT where the vehicle has failed for dangerous (do not drive until repaired) defects or category major (repair immediately) defects.
- 3b.72 With respect to a licensed vehicle, in the event of a proprietor failing to present to the Council an MOT test certificate as required (unless delayed or prevented by sufficient cause accepted and agreed by the Council), the Council may suspend the licence and require the proprietor of that hackney carriage to return all the plates to the Council subject to any appeal period.

MOT failures and advisories

- 3b.73 The Councils position in regards to MOT failures and advisories is as follows:
- Where a vehicle fails an MOT under the category dangerous (do not drive until repaired) defects, DVSA guidance states that this will have a direct and immediate risk which will put passengers and other road users at risk or have a serious impact on the environment. The Council requires all repairs to be undertaken and a new MOT test certificate issued before the vehicle is used as a hackney carriage.
 - Where a vehicle fails an MOT under the category major (repair immediately) defects, the Council has a concern for the vehicle safety which may put passengers and other road users at risk or have an impact on the environment. The Council requires all repairs to be undertaken and a new MOT test certificate issued before the vehicle is used as a hackney carriage.
- 3b.74 Where a proprietor permits a vehicle that has failed an MOT for dangerous (do not drive until repaired) defects, or major (repair immediately) defects, to be used as a hackney carriage, the licence will be referred to the Licensing Panel for review where an officer with delegated authority will consider each case on its own individual merits and will determine what action is appropriate and proportionate to the circumstances of the case.
- 3b.75 Shropshire Council reserves the right to require proprietors to rectify any items listed under minor or advisory information on an MOT certificate and to provide evidence that the work has been completed to the Council within a timescale specified by the Council. In the event that a proprietor fails to rectify any items requested by the Council (unless delayed or prevented by sufficient cause accepted and agreed by the Council), the Council may suspend the licence and require the proprietor of that hackney carriage to return all the plates to the Council subject to any appeal period.

Insurance

- 3b.76 Certificates of insurance are required in accordance with the following requirements:
- The vehicle must have a valid certificate of insurance for public hire, including proof of Public Liability insurance for a minimum of £5,000,000, throughout the licence period.
 - Certificates of insurance or cover notes issued to cover “any vehicle” or “any driver” must be accompanied by a schedule showing all the vehicles and drivers covered by the insurance as detailed in the certificate of insurance.
 - Where a vehicle is insured by a proprietor and the proprietor allows another licensed Shropshire Council driver to drive their vehicle, or any vehicle is insured under a fleet insurance, the proprietor (as the policy holder) is responsible for ensuring that the driver of

that vehicle is aware of the content of the policy, including its limitations and exclusions, and that the proprietor keeps records to this effect.

- Where an insurance cover note is provided a full certificate of insurance must be produced to the Council within 7 days of the certificate being received by the owner of the vehicle.
- The proprietor must also obtain information as to any requirement for them to have Employers Liability Indemnity; if there is such a requirement, it must be for a minimum of £1,000,000.

3b.77 With respect to a licensed vehicle, in the event of a proprietor failing to present to the Council a valid certificate of insurance as required (unless delayed or prevented by sufficient cause accepted and agreed by the Council), the Council may suspend the licence and require the proprietor of that hackney carriage to return all the plates to the Council subject to any appeal period.

Vehicle compliance process

3b.78 Once an application has been validated and accepted a member of the Licensing Team will contact the applicant to arrange a vehicle compliance appointment. At the appointment the vehicle will be subject to a compliance check to ensure:

- That the driver presenting the vehicle is capable of safely loading and securing a reference wheelchair into the vehicle (the vehicle, including seating, wheelchair restraint and ramp, will be photographed and the images held on the vehicle record file for future reference)
- The meter seal is intact and the serial number matches the number provided in the meter calibration certificate. Where a meter seal has been tampered with and/or the serial number no longer matches, a new certificate/report to confirm the vehicle is fitted with a taximeter in accordance with the requirements set out at paragraph 3b.47 will be required
- The vehicle has a full size spare wheel or space saver design wheel and the tools to change a wheel OR a contract with a mobile tyre replacement specialist
- At least one no smoking sign is on display in the vehicle
- A sign confirming the taxi is wheelchair accessible
- The drivers internal 'Vehicle Copy' of drivers badge is displayed ensuring that the licence details and photo are visible to passengers, and
- Where CCTV is fitted, a CCTV operating in this vehicle sign is on display in the vehicle

3b.79 Vehicle proprietors are required to return the existing licence plate (renewal/transfer vehicles only) at the compliance appointment. Where officers are satisfied that the vehicle meets the compliance checks, the new licence plates will be issued. If, however, the vehicle does not meet the compliance check, advice will be provided and a further appointment arranged.

Transfer of a licence (Change of vehicle)

3b.80 All requests to transfer a vehicle licence (change a vehicle) onto another vehicle will be treated as a new vehicle application (in accordance with the requirements set out at paragraphs 3b.37 to 3b.43).

3b.81 Where a proprietor has notified the Council that damage has occurred to a licensed wheelchair accessible vehicle, resulting in the transfer of licence to a temporary insurance replacement vehicle, proprietors will be required to provide evidence to demonstrate the damage which has occurred to the vehicle, i.e. insurance assessors report.

- 3b.82 Where the wheelchair accessible vehicle has sustained structural damage from a road traffic accident resulting in a DVLA classification under Category S – Structural damage (vehicle that has sustained damage after 1 October 2017) or Category C (vehicle has sustained damage, rendering it beyond economical repair, prior to 1 October 2017), any documents provided to meet the safety requirements of the policy as part of the previous application process (i.e. VCA certificate, IAC or IVA 6) may be invalid. In these circumstances the Council will require the proprietor to submit the vehicle for a new basic voluntary IVA check and provide a valid IVA 6 certificate to the Licensing Team before the licence can be transferred back to the original vehicle.
- 3b.83 Where the wheelchair accessible vehicle has sustained damage that does not affect the validity of the documents provided to meet the safety requirements of the policy as part of the previous application process (i.e. VCA certificate, IAC or IVA 6), provided any repairs have been made by a garage approved and authorised by the insurance company, the Council will require the proprietor to submit confirmation from the insurance company that the repairs have been completed in accordance with the insurance assessors report and a new MOT certificate (in accordance with the requirements set out at paragraph 3b.70 above) to the Licensing Team before the licence can be transferred back to the original vehicle.

Vehicle not fit for the conveyance of passengers

- 3b.84 Where a proprietor has notified the Council that damage has occurred to a vehicle, otherwise than in accordance with relevant road traffic legislation, the Council may require photographic evidence of the damage or for the vehicle to be presented for inspection by an authorised officer of the Council.
- 3b.85 If the authorised officer determines that a vehicle is not fit for the purpose of conveying passengers an authorised officer of the Council may at that time suspend the licence and require the proprietor of the vehicle to return all the vehicle plates to the Council. The suspension will be lifted and the plates returned at such time when the condition of the vehicle is demonstrated, to the satisfaction of the Council, to be fit for conveying passengers.
- 3b.86 The officer may require the proprietor to arrange for a further MOT test, or in respect of wheelchair accessible vehicles a basic voluntary IVA test, to be undertaken and certificate produced before the vehicle will be permitted to operate; this is at the discretion of the authorised officer.

Use of information on and in relation to hackney carriages

- 3b.87 Proprietors may display advertisements, information, images and other material on hackney carriages in accordance with the conditions set out at **Appendix L**. This is subject to prior written approval from the Council.
- Closed circuit television (CCTV)**
- 3b.88 Proprietors of hackney carriage vehicles are encouraged to install closed circuit television (CCTV) systems providing such systems are installed in accordance with the appropriate legal framework and the Council has been notified, in writing, of their intention to do so.
- 3b.89 Proprietors must register with the Information Commissioners Office (ICO) and maintain a valid registration throughout the duration of the licence or until such a time as the CCTV has been removed from the licensed vehicle.

Trailers

- 3b.90 Hackney carriages licensed by the Council are permitted to tow trailers when undertaking the licensable activity, providing the conditions set out at **Appendix M** are complied with at all times.

Ranks

- 3b.91 The Highways section of the Council is primarily responsible for the creation of ranks and will work with the hackney carriage trade, Licensing and West Mercia Police to determine where ranks/stands ought to be situated.

Parking/waiting

- 3b.92 Drivers of hackney carriage vehicles in the Council's area should, as soon as they have dropped passengers at their required destination and unless prevented from doing so by another booking, return to a suitably safe place to park that is not in contravention of road traffic legislation, traffic regulation orders and not likely to cause nuisance to others.
- 3b.93 Where a driver is plying for hire and is illegally parked or creating an obstruction, i.e. in contravention of road traffic legislation and traffic regulation orders, or if, in the opinion of an officer of the Council or police officer, the driver is plying for hire in a dangerous location (this does not include a legitimate period of time where a hackney carriage has stopped to drop off or pick up a fare), the driver's licence may be reviewed and such conduct may be deemed a reasonable cause to revoke or suspend the licence or to take any other appropriate action.

LPG converted vehicles

- 3b.94 The Council must be satisfied that any vehicle that has been converted to LPG has been converted correctly prior to a licence being issued. To this end, the Council will undertake checks with the UK LPG Vehicle Register.
- 3b.95 With respect to new applications, where it is established that a conversion has not been undertaken correctly and/or the vehicle is unsafe in any way, the Council will refuse the application.
- 3b.96 In the event that an LPG conversion has been undertaken on a vehicle during a current licensed period and the proprietor of the vehicle fails to notify the Council within 7 days of the conversion, an authorised officer of the Council will suspend the vehicle licence until such time as evidence is available on the UK LPG Vehicle Register.
- 3b.97 In the case of a conversion that has been undertaken on a vehicle during a current licensed period and it is subsequently established that the conversion has not been undertaken correctly and/or the vehicle is unsafe in any way, an authorised officer of the Council will suspend the licence until such time as the conversion has been undertaken correctly and/or it is demonstrated to the satisfaction of the Council that the vehicle is safe.

Hackney carriage fares

- 3b.98 The hackney carriage trade will be expected to apply for any change to the hackney carriage fares. The Council will consult with hackney carriage licence holders when a proposed change to the hackney carriage fares has been received. Proposals will be considered by the Strategic Licensing

Committee and advertised in the local press before they are adopted. This does not preclude the Council from putting forward changes to the fares or taking a decision not to accept the application from the trade.

Production of records/documents

3b.99 Any records required to be retained in accordance with the licence and licence conditions must be produced, on request, to any authorised officer of the Council or to any police officer.

Licence conditions

3b.100 The applicable conditions relevant to a hackney carriage licence are set out at **Appendix C**; these conditions must be complied with. These conditions are in addition to any matters set out within the main body of the Policy.

Main legal requirements

3b.101 Paragraphs 3b.102 to 3b.113 is not exhaustive and unless otherwise specified please refer to the Town Police Clauses Act 1847 and the Local Government (Miscellaneous Provisions) Act 1976 for a full list of legal requirements, offences and the maximum penalty upon conviction.

3b.102 Change of proprietor

The proprietor must give notice to the Council of any transfer in his interest in the hackney carriage vehicle to a person other than the proprietor whose name is specified in the licence. Such notice must be given, in writing, within 14 days specifying the name and address of the person to whom the vehicle has been transferred.

3b.103 Change of address

The proprietor of a hackney carriage must notify the Council in writing, within 7 days, of any change of their address.

3b.104 Retention of drivers licences

A proprietor of a hackney carriage must ensure that each driver's licence is lodged with the proprietor before the driver is employed to carry out work and must retain the licence in their possession for the period during which the driver remains in their employ. When a driver leaves the employ of a proprietor, the proprietor must return the driver's licence unless the licence holder has been guilty of misconduct in which case the operator may retain the licence and must issue a summons to have the cause of complaint determined by the Courts. (Note: If the Courts find that the licence has been improperly retained they have the powers to order its return and to award compensation.)

3b.105 Inspection

The proprietor must present their hackney carriage for inspection and testing by the Council as required, up to a maximum of 3 times during any one period of 12 months.

3b.106 The proprietor must provide, on request, the address where the hackney carriage is kept and allow the Council to inspect and test the vehicle at that address.

3b.107 Accidents

The proprietor, notwithstanding their responsibilities under relevant road traffic legislation, must also report to the Council any accident as soon as reasonably practicable. However, where the vehicle has suffered accident damage that materially affects the safety, performance or appearance of the vehicle, or the comfort or convenience of fare paying passengers, the driver must notify the Council within 72 hours.

3b.108 Production of documents

The proprietor must, on request by an authorised officer of the Council or a police officer, produce to the officer for inspection the hackney carriage vehicle licence and insurance certificate within 7 days.

3b.109 Return of identification plates

Where a licence is revoked, suspended or expires, the proprietor, when required by the Council to do so, must return all the identification plates within 7 days.

3b.110 Transporting children

As a minimum, vehicles must be capable of complying with the requirements set out in the table below, for further guidance see <https://www.gov.uk/child-car-seats-the-rules/when-a-child-can-travel-without-a-car-seat>.

	Front seat	Rear seat	Who is responsible?
Child up to 3 years	Correct child restraints must be used	Correct child restraint must be used. If a restraint is not available in a licensed hackney carriage or private hire vehicle, the child may travel unrestrained.	Driver**
Child from 3rd birthday to 12th birthday or 135 cm in height whichever they reach first	Correct child restraints must be used	Where seat belts are fitted, the correct child restraint must be used. The child must use adult belt if the correct child restraint is not available as follows: in a licensed hackney carriage or private hire vehicle; or for a short distance in an unexpected necessity; or two occupied child restraints prevent fitting of a third. A child 3 years and over may travel unrestrained in the rear seat of a vehicle if seat belts are not fitted in the rear.	Driver**
Child over 135 cm in height or 12 or 13 years old	Seat belt must be worn if available*	Seat belt must be worn if available.	Driver**
Passengers aged 14 years and over	Seat belt must be worn if available*	Seat belt must be worn if available.	Passenger

*Vehicles built before 1965 are not required to have fitted seatbelts.

**Drivers must inform parents/carers that the decision to permit children to travel in the vehicle, without the correctly sized seat restraints (as permitted by relevant legislation) and with the

obvious risks associated with such an action, remains with the parent/carer responsible for the children and not with the driver of the vehicle.

3b.111 Ranks

Hackney carriage ranks/stands are provided in accordance with the Local Government (Miscellaneous Provisions) Act 1976. The Council may appoint ranks/stands for hackney carriages. It is not a mandatory statutory requirement for the Council to do so. Before providing ranks/stands the Council will liaise with the police and the Highways section of the Council and where the location of a rank is on private land the Council must obtain permission of the landowner.

3b.112 Fares

Drivers of hackney carriages must not charge more than is permitted under the current table of fares. Drivers undertaking journeys ending outside the Council's area and in respect of which no fare and no rate of fare was agreed before the journey commenced must not charge more than that indicated on the taximeter or more than the current table of fares allows.

3b.113 Where a hackney carriage is used for a private hire contract the fare charged must not exceed the fares set down in the current table of fares. The fare or charge is calculated from the point at which the hirer commences the journey within the administrative area of Shropshire Council.

Summary

- 3c.1 Private hire vehicles are licensed in accordance with the provisions of the Local Government (Miscellaneous Provisions) Act 1976. Private hire vehicles must not have the appearance of a hackney carriage vehicle.
- 3c.2 When considering whether a vehicle is a private hire vehicle, by the nature of the work it does, Shropshire Council shall have regard to the document Private Hire Vehicle Licensing - A note for guidance from the Department for Transport (August 2011).
- 3c.3 The Council legally cannot limit the number of private hire vehicle licences that it will issue.
- 3c.4 The Council will not licence a vehicle for hire and reward which is licensed by another local authority or allow or permit a private hire vehicle identification plate issued by another authority to be displayed on the vehicle.

Applicant

- 3c.5 The applicant for a vehicle licence must be the person who is the legal owner of the vehicle concerned and entitled to have ownership of the vehicle¹³.

Fit and proper person

- 3c.6 The proprietor of a licensed private hire vehicle provides a public service that impacts on public safety. On this basis, the Council will not licence a vehicle as a private hire vehicle unless it is satisfied that the proprietor of the vehicle meets all the criteria to be deemed a fit and proper person as set out in **Appendix I**.

Proprietors who apply for a private hire vehicle licence and who hold a valid Shropshire Council hackney carriage/private hire drivers licence or a valid Shropshire Council private hire operator licence

- 3c.7 The Council adopts the same principles when determining whether an applicant is a fit and proper person to hold a vehicle licence as it does to persons applying for a drivers licence. In this respect, applicants are required to have due regard, as appropriate, to the requirements and information set out at paragraphs 3a.4 to 3a.24 of the Policy.

Proprietors who apply for a private hire vehicle licence and who do not hold a valid Shropshire Council hackney carriage/private hire drivers licence or a valid Shropshire Council private hire operator licence

- 3c.8 In considering the fit and proper person test, all applicants on initial application must provide a basic criminal record disclosure from the Disclosure and Barring Service. All applicants on renewal must provide a basic criminal record disclosure that has been issued by the Disclosure and Barring Service within the previous 12 months of the date that the application is received by the Council. On new and renewal applications the Council will also make additional enquiries through its adults

¹³ There is no legal definition of proprietor within relevant legislation; however, the Council has taken the view that proprietor means the legal owner based on common usage of the term.

and childrens social care teams, directly with West Mercia Police (and other relevant police forces, where appropriate), other relevant local authorities (particularly Telford & Wrekin Council and City of Wolverhampton Council) and any other appropriate organisation, agency or person in order to ensure the Council is in a position to make as accurate an assessment of the applicant's fitness to hold a licence as is reasonably practicable.

- 3c.9 With specific reference to existing licence holders, where there is any cause for a licence to be reviewed, the Council will make additional enquiries through its adults and childrens social care teams, directly with West Mercia Police (and other relevant police forces, where appropriate), other relevant local authorities (particularly Telford & Wrekin Council and City of Wolverhampton Council) and any other appropriate organisation, agency or person in order to ensure the Council is in a position to make as accurate an assessment of the licence holders fitness to hold a licence as is reasonably practicable. Depending on the circumstances of the case, the Council may request the licence holder to consent to a further basic criminal record disclosure, the cost of which lies with the licence holder. Where a licence holder refuses to consent to a further check the Council will take this into consideration in determining their continuing fitness to hold a licence.
- 3c.10 When assessing the fitness of an applicant to hold a private hire vehicle proprietors licence, the Council will consider the applicant's criminal history as a whole, together with all other relevant evidence, information and intelligence including their history (e.g. complaints and positive comments from the public, compliance with licence conditions and willingness to co-operate with licensing officers) whilst holding a licence from the Council or any other authority. Particular attention will be given to patterns of behaviour, irrespective of the time-scale over which they have occurred, both in terms of proven criminal offences and other behaviour/conduct that may indicate the safety and welfare of the public may be at risk from the applicant.
- 3c.11 In addition, an important element associated with the fitness to hold a licence is the appearance and behaviour of an applicant. Consequently, the Council requires all applicants to maintain a reasonable standard of appearance and behaviour when in contact and dealing with all persons, including but not limited to, other road users, pedestrians, customers, the general public, other licensed operators and drivers of hackney carriage and private hire vehicles, Council officers and elected members at all times. Applicants must also co-operate with any reasonable request made by an authorised officer of the Council or any police officer.
- 3c.12 It must also be recognised that the Council will consider all relevant criminal history, behaviour and conduct irrespective of whether the specific history, behaviour or conduct occurred whilst applicants were directly engaged in hackney carriage or private hire licensed work at the time or whether they occurred during the applicants' own personal time. The Council considers a person or individual who has a propensity to commit offences and/or demonstrate unacceptable conduct whilst not engaged in hackney carriage or private hire work to be equally as serious as offences and/or unacceptable conduct committed whilst engaged in hackney carriage or private hire work.

Criminal record disclosure

- 3c.13 All unspent convictions, including cautions, will be taken into account when considering a person's suitability to hold a licence. Consequently, applicants are required to provide details of all unspent convictions and cautions, including driving endorsements (driving convictions) and disqualification periods relating to traffic offences.
- 3c.14 Although cautions are generally not as serious as convictions, ordinarily as a result of the circumstances under which they are offered, they do require an admission of guilt before they can

be issued which is equivalent to a guilty plea on prosecution. Consequently, a caution is regarded in exactly the same way as a conviction. Fixed penalties, community resolutions or similar sanctions will also be considered in the same way as a conviction on the basis that payment of a fixed penalty indicated an acceptance of guilt and a community resolution can only be imposed following an admission of guilt. As a result, each of these sanctions is a valuable indication as to an applicant's character and whether they are a fit and proper person to hold or be granted a licence.

- 3c.15 A criminal record does not automatically bar an applicant from holding a licence; however, it will be a significant factor when determining whether a licence ought to be granted or not. Where an applicant has previous criminal convictions, these will be considered in line with the guidance set out in **Appendix I**. However, the over-riding consideration will always be to ensure the safety and welfare of the public.
- 3c.16 Persons who have not been resident within the United Kingdom for the five years prior to submitting an application, will be required to produce a certificate of good conduct or equivalent document (at their own cost) issued by the relevant Embassy or High Commission. The certificate must be authenticated, translated and sealed by the Embassy or High Commission. In the event that an applicant is not able to obtain a certificate of good conduct, they may submit a statutory declaration with regard to their conduct, which must be completed in the presence of a practising solicitor. The Council may contact the relevant Embassy, High Commission, solicitor or other appropriate body to verify any documents provided. Contact details for Embassies and High Commissions can be found from the Foreign, Commonwealth & Development Office (FCDO) on the GOV.UK website at <https://www.gov.uk/government/world>. The FCDO may be contacted for further assistance by telephone on 020 7008 5000, by email at fcdo.correspondence@fcdo.gov.uk or by post at the FCDO, King Charles Street, London, SW1A 2AH.
- 3c.17 Applicants who have spent three continuous months or more living outside the United Kingdom, during the period of their licence, will be required to produce a certificate of good conduct or equivalent document (at their own cost). This certificate must be issued by the relevant Embassy or High Commission for the country or countries lived in during this period and meet the requirements as set out at 3c.16 above. It is recognised that some countries will not provide a certificate of good conduct unless the individual has been resident for six months or more. Where a relevant Embassy or High Commission refuse to issue a certificate of good conduct, applicants must provide written confirmation from the Embassy of any refusal to the Licensing Team.

Non-conviction information

- 3c.18 In addition to conviction/caution information, applicants are expected to provide details, within 48 hours of all warnings, driving endorsements (driving convictions)/disqualification periods relating to traffic offences, fixed penalties, community resolutions and any other similar sanctions, together with any charges or arrests that they are the subject of in connection with criminal offences, whether or not actually charged with the offence, and details of any allegations of involvement in criminal activity or where they have been questioned in connection with any alleged criminal activity or inappropriate/unacceptable behaviour or any other relevant pending matter.
- 3c.19 Where an applicant is the subject of an outstanding charge or summons, their application may continue to be processed; however, depending on the circumstances, it is unlikely that a decision on the application will be made until the conclusion of the criminal proceedings. Where the outstanding charge or summons involves a serious offence and/or the individual's offending

history and behaviour/conduct indicates a pattern of unlawful or unacceptable behaviour/character traits, then the application is likely to be refused.

3c.20 Where there is evidence/information that an applicant has been arrested or charged but not convicted of offences and the nature of this evidence/information suggests the applicant may not be a fit and proper person, the Council will give serious consideration to refusing an application or revoking an existing licence.

Period of licence

3c.21 Vehicle licences will be issued for a maximum period of 12 months.

Vehicle licence plates

3c.22 The external plates (front and rear) and the internal plate, identifying the vehicle as a private hire vehicle, show the licence details on a yellow background with the Shropshire Council logo.

Vehicle specification

3c.23 The Council requires private hire vehicles to comply with the following requirements:

Emissions/Age Restrictions

3c.24 Vehicles that are not wheelchair accessible vehicles must comply with the following:

Renewal/New Application	Fuel	Period	European Emission / Age Standard
New	Petrol	1 April 2023 to 31 March 2024	Euro 5
New	Petrol	1 April 2024 to 31 March 2028	Euro 5 and where the vehicle is less than 10 years old from date of first registration
New	Diesel	1 April 2023 to 31 August 2025	Euro 6/Euro 6d and where date of first registration is on or after 1 September 2016
New	Diesel	1 September 2025 to 31 March 2028	Euro 6 / Euro 6d and where the vehicle is less than 6 years old from date of first registration
New	Full electric	1 April 2023 to 31 March 2028	Any age
New	Hybrid petrol	1 April 2023 to 31 March 2028	Less than 10 years old from date of first registration

New	Hybrid diesel	1 April 2023 to 31 March 2028	Less than 8 years old from date of first registration
New	LPG	1 April 2023 to 31 March 2028	Less than 10 years old from date of first registration
Renewal	Petrol	1 April 2023 to 31 March 2024	Euro 5
Renewal	Petrol	1 April 2024 to 31 March 2028	Euro 5 and where the vehicle is less than 12 years old from date of first registration
Renewal	Diesel	1 April 2023 to 31 March 2025	Euro 5 / Euro 6 / Euro 6d and where the vehicle is less than 10 years old from date of first registration
Renewal	Diesel	1 April 2025 to 31 March 2028	Euro 6 / Euro 6d and where the vehicle is less than 10 years old from date of first registration
Renewal	Full electric	1 April 2023 to 31 March 2028	Any age
Renewal	Hybrid petrol	1 April 2023 to 31 March 2028	Less than 12 years old from date of first registration
Renewal	Hybrid diesel	1 April 2023 to 31 March 2028	Less than 10 years old from date of first registration
Renewal	LPG	1 April 2023 to 31 March 2028	Less than 12 years old from date of first registration

3c.25 The following is applicable to **wheelchair accessible vehicles only**. Vehicles that **are** wheelchair accessible vehicles must comply with the following:

Renewal/New Application	Fuel	Period	European Emission / Age Standard
New	Petrol	1 April 2023 to 31 March 2024	Euro 5
New	Petrol	1 April 2024 to 31 March 2028	Euro 5 and where the vehicle is less than 12 years old from date of first registration

New	Diesel	1 April 2023 to 31 August 2025	Euro 6/Euro 6d and where date of first registration is on or after 1 September 2016
New	Diesel	1 September 2025 to 31 March 2028	Euro 6 / Euro 6d and where the vehicle is less than 6 years old from date of first registration
New	Full electric	1 April 2023 to 31 March 2028	Any age
New	Hybrid petrol	1 April 2023 to 31 March 2028	Less than 12 years old from date of first registration
New	Hybrid diesel	1 April 2023 to 31 March 2028	Less than 10 years old from date of first registration
New	LPG	1 April 2023 to 31 March 2028	Less than 12 years old from date of first registration
Renewal	Petrol	1 April 2023 to 31 March 2024	Euro 5
Renewal	Petrol	1 April 2024 to 31 March 2028	Euro 5 and where the vehicle is less than 15 years old from date of first registration
Renewal	Diesel	1 April 2023 to 31 March 2025	Euro 5 / Euro 6 / Euro 6d and where the vehicle is less than 12 years old from date of first registration
Renewal	Diesel	1 April 2025 to 31 March 2028	Euro 6 / Euro 6d and where the vehicle is less than 12 years old from date of first registration
Renewal	Full electric	1 April 2023 to 31 March 2028	Any age
Renewal	Hybrid petrol	1 April 2023 to 31 March 2028	Less than 15 years old from date of first registration
Renewal	Hybrid diesel	1 April 2023 to 31 March 2028	Less than 12 years old from date of first registration

Renewal	LPG	1 April 2023 to 31 March 2028	Less than 15 years old from date of first registration
---------	-----	-------------------------------	--

NB The charts above provide information for the licensing of vehicles up to 31 March 2028 and the maximum age for a vehicle to remain licensed. The Council does not currently intend to make any changes in the future to reduce the maximum age for a vehicle to remain licensed where a vehicle had already been licensed before 31 March 2028. However, the Policy will be subject to continuous evaluation and, if necessary, can be formally reviewed at any time.

Safety

3c.26 The Council will not licence any new vehicle that since the date of first registration has been recorded by the DVLA as having sustained structural damage resulting from a road traffic accident (an insurance 'Write Off' under the DVLA's Category S – Structural damage classification for vehicle that has sustained damage after 1 October 2017 or Category C where a vehicle has sustained damage, rendering it beyond economical repair, prior to 1 October 2017). This information can be found in the Special Notes section of the V5 registration Certificate.

3c.27 Vehicles must meet the following safety standards as defined by the European New Car Assessment Programme (NCAP). In this respect, the Overall Rating must be used. Where the Overall Rating is not available, the Adult Rating is the relevant standard:-

- All new vehicle applications submitted on or after 1 April 2023 are required to be NCAP 5 star.
- All renewal vehicle applications submitted on or after 1 April 2023 are required to be NCAP 5 star.

NB Applicants wishing to purchase a new vehicle that meets the requirements of the age/emissions section of this Policy, however, to which no NCAP safety rating has been applied, are advised to contact the Council for advice prior to purchase. An application may be considered if the applicant is able to demonstrate exceptional circumstances to satisfy the Council that it would not frustrate the purposes of this Policy or compromise public safety if the licence were granted.

3c.28 The requirements of 3c.27 do not apply to private hire vehicles that have been specifically constructed or converted for disability access and any M1 (not M2 or N1) vehicles that have been adapted to be a private hire vehicle (and has been accepted by an authorised officer of the council to be licensed only as a private hire vehicle) where:

- The vehicle has come off the production line as a purpose-built wheelchair accessible vehicle there will be a Vehicle Certification Agency (VCA) certificate which demonstrates that the vehicle has been constructed to an acceptable safety standard, providing there have been no changes to the layout of the vehicle since the VCA was issued.
- The vehicle is modified after production, but before first registration, there may be an Individual Approval Certificate (IAC) available, which will demonstrate that the adaptations have been tested by DVSA (VOSA) and are to an acceptable safety standard, providing there have been no changes to the conversion since the IAC was issued. This may be referred to as a Statutory Individual Vehicle Approval.

- Vehicles that are converted for disability access after first registration have been submitted for a Basic Voluntary IVA (Individual Vehicle Approval). This is the route that vehicles are required to take where there is no VCA certificate or IAC available. Vehicles must be presented to the DVSA for a Basic Voluntary IVA inspection Class P – Personal Import. If the vehicle passes the inspection it will receive a Certificate of Compliance (IVA 6). The Voluntary IVA checks the whole of the vehicle, not only the parts that have been converted and is similar to a very strict MOT test.

3c.29 Where a proprietor has notified the Council that a licensed vehicle has sustained structural damage from a road traffic accident resulting in a DVLA classification under Category S – Structural damage (vehicle that has sustained damage after 1 October 2017) or Category C (vehicle has sustained damage, rendering it beyond economical repair, prior to 1 October 2017), any documents provided to meet the safety requirements of the policy as part of the previous application process (i.e. NCAP safety report or IVA certificate) will be invalid. The proprietor will be required to submit the vehicle for a new voluntary IVA check and provide a valid IVA certificate to the Licensing Team.

List of Designated Wheelchair Accessible Vehicles

3c.30 Section 167 of the Equality Act 2010 requires all Local Authorities to maintain a list of designated wheelchair accessible vehicles.

3c.31 All wheelchair accessible vehicles must be capable of transporting the user of a “reference wheelchair” and will be included within Shropshire Councils list of designated vehicles. Specifications for a “reference wheelchair” can be found at **Appendix J**.

3c.32 Section 172 of the Equality Act 2010 provides for an appeal to be made against the decision to include a vehicle on the list of designated wheelchair accessible vehicles. Any appeal must be made to the Magistrates Court within 28 days of the vehicle being included on the list.

3c.33 Proprietors have a responsibility to ensure that any Shropshire Council licensed driver who drives one of their wheelchair accessible vehicles is made aware of their duties in respect of carrying disabled persons in wheelchairs when driving a designated wheelchair accessible vehicle.

3c.34 Failure to comply with the duties listed under section 165 of the Equality Act 2010 is a criminal offence.

Other Requirements

3c.35 Vehicles must not seat more than eight passengers (not including the driver) and:

- (a) Be a Light Passenger Vehicle as defined by section 85 of the Road Traffic Act 1988 and have a minimum of 4 wheels
- (b) Provide sufficient means by which any person in the carriage may communicate with the driver
- (c) Vehicle owners and operators are encouraged to use vehicles where the entire external bodywork of the vehicle is NOT black in colour. This does not prohibit the display of advertisements, information, images or other material as authorised by the Council
- (d) All paintwork must be maintained in a uniform colour and free from dents, scratches or rust
- (e) Have a watertight roof or covering

- (f) Provide at least two windows on each side of the vehicle of which one window on one side must have a means of opening/closing
- (g) Tinted windows will only be permitted in accordance with the manufacturers or specialist coachbuilder's specification and must comply with the Road Vehicles (Construction & Use) Regulations 1986 as amended. The Council will not permit any form of additional film to darken or tint the glass on any part of the vehicle
- (h) Have seats that are properly cushioned and covered
- (i) Have a floor provided with a proper carpet, mat, or other suitable covering
- (j) Have fittings (including fittings that are used to secure wheelchairs to the floor of the vehicle) and furniture in a clean condition and be well maintained and in every way fit for public service
- (k) Provide means for securing luggage if the carriage is so constructed as to carry luggage
- (l) Where tilting passenger seats are fitted the seat must:
 - Be forward facing (with the exception of the fold down seats fitted onto the bulkhead/partition of a purpose-built vehicle)
 - Designed for use by an adult
 - Have a three point seatbelt
- (m) Have a minimum of four passenger doors including an entry/exit point for the driver
- (n) Be maintained in a sound mechanical and structural condition at all times
- (o) Have a full size spare wheel or space saver design wheel and the tools to change a wheel OR a contract with a mobile tyre replacement specialist (in any event where a spare wheel has been used, it is only to permit the current fare to be completed and any defective wheel must be replaced before taking another fare to ensure passenger safety); all pneumatic tyres, including the spare, must comply with the vehicle manufacturer's specification and any relevant legislation
- (p) Be maintained in a clean and safe condition at all times from both exterior and interior perspectives
- (q) Proprietors are encouraged to have provision for the legal transportation of a minimum of one reference wheelchair at all times. Specifications for a "reference wheelchair" can be found at **Appendix J**
- (r) When transporting a wheelchair user, where a seat has to be removed in order to accommodate a passenger in a wheelchair, proprietors must store the seat securely away from the passengers and driver (e.g. in the boot or other suitable storage facility away from the vehicle)
- (s) Where a mechanical ramp is fitted, comply with requirements of the Lifting Operations and Lifting Equipment Regulations 1998
- (t) Where a non-mechanical ramp is fitted, comply with the relevant provisions of the Provision and Use of Work Equipment Regulations 1998, and
- (u) When transporting a wheelchair user, where the wheelchair user chooses to transfer to a passenger seat, proprietors must store the wheelchair securely away from the passengers and driver (e.g. in the boot)

New application process

- 3c.36 The application form must be fully completed and include all relevant information, supporting documentation and appropriate fee.
- 3c.37 The full fee for the licence is payable at the time the application is submitted. (This includes any application to transfer a vehicle licence onto another vehicle)

3c.38 If any part of the application form is incomplete or the relevant information or supporting documentation is not provided, the applicant will be requested to provide the missing information/documentation and informed that the application will not be processed until such time as all the information/documentation is provided. If the applicant fails to provide all the information to complete the application, the application will be rejected.

3c.39 Once an application has been accepted by the Licensing Team as a valid application the application process must be completed within 6 months unless prevented from doing so by matters that are outside the applicant's control. When an application is not completed within this timescale the application will be referred to the Licensing Panel for determination where an officer with delegated authority will consider each case on its own individual merits and will determine what action is appropriate and proportionate to the circumstances of the case.

3c.40 Any person wishing to licence a private hire vehicle must:

- Submit a completed application form
- Submit a completed reference form, unless the applicant is the holder of a hackney carriage and private hire drivers licence or private hire operator licence issued by Shropshire Council (NB the referees must be from either professional or business sources who have known the applicant for at least two years. In addition, the Council will not accept references from family members, drivers, operators, vehicle proprietors licensed with any local authority or, where relevant, the applicant's future employer unless there is satisfactory evidence of exceptional circumstances that are accepted by the Council). The Council reserves the right to refuse a reference where the Council deems the referee is not acceptable
- Pay the appropriate licence fee
- Provide a basic criminal record disclosure from the Disclosure and Barring Service, unless the applicant is the holder of a hackney carriage and private hire drivers licence or private hire operator licence issued by Shropshire Council (applicants can apply to <https://www.gov.uk/request-copy-criminal-record>). A basic criminal record disclosure will only be accepted by the Council within 12 months of the date of issue from the Disclosure and Barring Service
- Provide a valid MOT (in accordance with the requirements set out at paragraph 3c.47 below)
- Provide a valid certificate of insurance for private hire, including proof of Public Liability insurance for a minimum of £5,000,000, in accordance with the requirements set out at paragraph 3c.51 below
- Provide the full V5 registration certificate (note the alternative interim measure outlined in paragraphs 3c.53 to 3c.56)
- Where a meter is fitted, a valid certificate/report to confirm the vehicle is fitted with a taximeter in accordance with the requirements set out at paragraph 3c.46 below
- Provide evidence of compliance with the relevant European Emission/Age Standards as set out in paragraph 3c.24, or in the case of a wheelchair accessible vehicle as set out in paragraph 3c.25, either at the point of vehicle construction or by a subsequent adaption or conversion approved by the Council - the compliance must be relevant to the engine installed in the vehicle and this must be reflected in the V5 registration certificate
- Provide evidence of compliance with the relevant European New Car Assessment Programme (NCAP) rating as set out in paragraphs 3c.26 to 3c.28
- Where the vehicle is fitted with a mechanically operated ramp, provide a valid certificate/report confirming the ramp complies with the requirements of the Lifting Operations and Lifting Equipment Regulations 1998 (NB The proprietor is responsible for

ensuring that a competent person carries out the necessary checks in accordance with these Regulations.)

- Where non-mechanical ramps are used, provide confirmation from the proprietor of the vehicle that the ramps comply with the relevant provisions of the Provision and Use of Work Equipment Regulations 1998. (NB Licensing officers will check that the provision of non-mechanical ramps is being maintained by the vehicle proprietor.)
- Where fittings are used to secure wheelchairs to the floor of a vehicle, provide a certificate/report confirming that all the fittings are intact and are free from damage and wear

3c.41 Once an application has been validated and accepted, the Council will:

- Make enquiries through the Councils adults and childrens social care teams, West Mercia Police (or other relevant force), other local authorities and any other organisation, agency or person that the Council has deemed appropriate to seek information from, and
- Where applicable, write to the referees provided

3c.42 **NB** For partnerships or companies, the requirements set out in paragraphs 3c.5 to 3c.20 apply to all partners and directors/company secretaries.

3c.43 Where an application is received to change the proprietor of a private hire vehicle licence (transfer of licensee), the new proprietor must fulfil the requirements as set out in paragraphs 3c.5 to 3c.20 above.

3c.44 Paragraphs 3c.5 to 3c.20 above do not apply to applications to transfer a vehicle licence onto another vehicle, on a temporary basis, by an accident management company.

3c.45 Providing the above are satisfied, Officers will grant the licence. In all other cases, the application will be referred to the Licensing Panel for determination. Each application will be decided on its merits. However, there is a presumption that unless an applicant can demonstrate exceptional circumstances the application will be refused. Whilst it is neither possible nor prudent to draw up a list of what might amount to exceptional circumstances, an applicant who claims that exceptional circumstances exist will be expected to be able to satisfy the Council that it would not frustrate the purposes of this Policy or compromise public safety if the licence were granted. The applicant will be notified in writing if their application is to be determined at a meeting of the Licensing Panel.

Taximeters

3c.46 Private hire vehicles will not require a meter. However, if a meter is fitted, it must be:

- Certified by a notified body in accordance with the Measuring Instruments Directive (MID) (2004/22/EC), in particular Annex 007
- Fitted with a device, the use/action of which will bring the taximeter into action and cause the word 'HIRED' to appear on the face of the taximeter and such a device must be capable of being locked in a position such that the machinery of the taximeter is not in action and that no fare is recorded on the face of the taximeter
- Calibrated against a measured distance and by reference to the private hire operator's tariff
- Fixed to the vehicle with appropriate seals/appliances to prevent any person from tampering with the meter except by breaking, damaging, or permanently displacing the seals/appliances

- Have the word 'FARE' printed on the face of the meter in plain letters so as clearly to apply to the fare recorded thereon, and
- Supported by a Shropshire Council certificate/report of compliance (the Council will only accept a certificate that has been issued within the previous 10 working days)

MOT requirements¹⁴

3c.47 MOTs are required in accordance with the following requirements:

- Vehicles, up to 9 years from date of first registration, must be submitted for an MOT inspection at 6-monthly intervals (and any other inspection deemed necessary by an authorised officer) and the applicant must produce valid MOT certificates to the Council in this respect.
- Once a vehicle reaches the age of 9 years, in addition to the MOT certificate submitted with an application, it must have two other MOT tests per year; tests being spaced evenly throughout the year at four monthly intervals and the applicant must produce valid MOT certificates to the Council in this respect.
- MOT certificates will only be accepted by the Council within 10 working days of the date of issue from the MOT testing centre.
- MOTs must be undertaken by a 'Nominated Tester' or Authorised Vehicle Examiner at a Vehicle Testing Station appointed under Section 45 of The Road Traffic Act 1988; the cost of all tests must be met by the vehicle proprietor.
- The vehicle must have a valid MOT throughout the licence period.

3c.48 With respect to a licensed vehicle, in the event that a proprietor fails to present to the Council an MOT test certificate as required (unless delayed or prevented by sufficient cause accepted and agreed by the Council), the Council may suspend the licence and require the proprietor of that private hire vehicle to return all the plates to the Council subject to any appeal period.

MOT failures and advisories

3c.49 The Councils position in regards to MOT failures and advisories is as follows:

- Where a vehicle fails an MOT under the category dangerous (do not drive until repaired) defects, DVSA guidance states that this will have a direct and immediate risk which will put passengers and other road users at risk or have a serious impact on the environment. The Council requires all repairs to be undertaken and a new MOT test certificate issued before the vehicle is used as a private hire vehicle.
- Where a vehicle fails an MOT under the category major (repair immediately) defects, the Council has a concern for the vehicle safety which may put passengers and other road users at risk or have an impact on the environment. The Council requires all repairs to be undertaken and a new MOT test certificate issued before the vehicle is used as a private hire vehicle.

3c.50 Shropshire Council reserves the right to require proprietors to rectify any items listed under minor or advisory information on an MOT certificate and to provide evidence that the work has been completed to the Council within a timescale specified by the Council. In the event that a proprietor fails to rectify any items requested by the Council (unless delayed or prevented by sufficient cause accepted and agreed by the Council), the Council may suspend the licence and require the

¹⁴ The requirement to submit an MOT will be in accordance with section 50 of the Local Government (Miscellaneous Provisions) Act 1976

proprietor of that hackney carriage to return all the plates to the Council subject to any appeal period.

Insurance

3c.51 Certificates of insurance are required in accordance with the following requirements:

- The vehicle must have a valid certificate of insurance for private hire including proof of Public Liability insurance for a minimum of £5,000,000, throughout the licence period. Insurance stating covered for public hire will not be accepted for private hire vehicles.
- Certificates of insurance or cover notes issued to cover “any vehicle” or “any driver” must be accompanied by a schedule showing all the vehicles and drivers covered by the insurance as detailed in the certificate of insurance.
- Where a vehicle is insured by a proprietor and the proprietor allows another licensed Shropshire Council driver to drive their vehicle, or any vehicle is insured under a fleet insurance, the proprietor (as the policy holder) is responsible for ensuring that the driver of that vehicle is aware of the content of the policy, including its limitations and exclusions, and that the proprietor keeps records to this effect.
- Where an insurance cover note is provided a full certificate of insurance must be produced to the Council within 7 days of the certificate being received by the owner of the vehicle.
- The proprietor must also obtain information as to any requirement for them to have Employers Liability Indemnity; if there is such a requirement, it must be for a minimum of £1,000,000.

3c.52 With respect to a licensed vehicle, in the event that a proprietor fails to present to the Council a valid certificate of insurance as required (unless delayed or prevented by sufficient cause accepted and agreed by the Council), the Council may suspend the licence and require the proprietor of that private hire vehicle to return all the plates to the Council subject to any appeal period.

V5 registration certificate

3c.53 The Council accepts that a full V5 registration certificate in the new owner’s name is not always available upon first licence or as part of an application to transfer the licensee; however, the green new keepers slip of the V5 form and proof of purchase must be produced. Where possible a full copy of the previous owners V5 registration certificate should be obtained and submitted alongside the green new keepers slip.

3c.54 A full V5 registration certificate and proof of purchase must be produced upon transfer of a vehicle licence. Where possible a full copy of the previous owners V5 registration certificate should be obtained and submitted alongside the V5 green section.

3c.55 Where the green section has been produced on first licensing the vehicle or as part of an application to transfer the licensee, a full V5 registration certificate in the new owner’s name must be produced to the Council within 7 days of the form being received by the owner of the vehicle.

3c.56 Where a licence is issued in advance of a full V5 registration certificate being received and where upon receipt of a full V5 registration certificate information is contained that indicates that a vehicle has, since the date of first registration, been recorded by the DVLA as having sustained structural damage resulting from a road traffic accident, as set out in paragraph 3c.26, the licence will be subject to review at a meeting of the Councils Licensing Panel.

Renewal of a licence

- 3c.57 To allow the vehicle's licence to be renewed, a renewal application form must be received by the Council at least 10 working days prior to the expiry date of the original licence (unless there is satisfactory evidence of exceptional circumstances that are accepted by the Council) to allow the Council sufficient time to process the renewal application. It is the Council's intention to process all valid renewal applications within 10 working days; hence, where applicants fail to submit their renewal application within this timescale, the risk that their licence will expire increases. Once a licence expires, is revoked (subject to a statutory appeal process) or surrendered, it ceases to exist and applicants would not be permitted to drive the private hire vehicle in these circumstances.
- 3c.58 Once a licence ceases to exist a renewal application will not be accepted by the Council (unless there is satisfactory evidence of exceptional circumstances that are accepted by the Council) and the applicant must submit a new vehicle licence application which will be processed in accordance with the Council's new application process.

Renewal application process

- 3c.59 The application form must be fully completed and include all relevant information, supporting documentation and appropriate fee.
- 3c.60 The full fee for the licence is payable at the time the application is submitted. (This includes any application to transfer a vehicle licence onto another vehicle)
- 3c.61 If any part of the application form is incomplete or the relevant information or supporting documentation is not provided, the applicant will be requested to provide the missing information/documentation and informed that the application will not be processed until such time as all the information/documentation is provided. If the applicant fails to provide all the information to complete the application, the application will be rejected.
- 3c.62 Once an application has been accepted by the Licensing Team as a valid application the application process must be completed within 6 months unless prevented from doing so by matters that are outside the applicant's control. When an application is not completed within this timescale the application will be referred to the Licensing Panel for determination where an officer with delegated authority will consider each case on its own individual merits and will determine what action is appropriate and proportionate to the circumstances of the case.
- 3c.63 Any person wishing to renew a licence for a private hire vehicle must:
- Submit a completed application form
 - Pay the appropriate licence fee
 - Provide a basic criminal record disclosure from the Disclosure and Barring Service, unless the applicant is the holder of a hackney carriage and private hire drivers licence or private hire operator's licence issued by Shropshire Council (applicants can apply to <https://www.gov.uk/request-copy-criminal-record>). A basic criminal record disclosure will only be accepted by the Council within 12 months of the date of issue from the Disclosure and Barring Service
 - Provide a valid MOT (in accordance with the requirements set out at paragraph 3c.68 below)
 - Provide a valid certificate of insurance for private hire including proof of Public Liability insurance for a minimum of £5,000,000, insurance stating covered for public hire will not be

accepted for private hire vehicles, in accordance with the requirements set out at paragraph 3c.74 below

- Where the vehicle is fitted with a mechanically operated ramp, provide a valid certificate/report confirming the ramp complies with the requirements of the Lifting Operations and Lifting Equipment Regulations 1998 (NB The proprietor is responsible for ensuring that a competent person carries out the necessary checks in accordance with these Regulations.)
- Where non-mechanical ramps are used, provide confirmation from the proprietor of the vehicle that the ramps comply with the relevant provisions of the Provision and Use of Work Equipment Regulations 1998. (NB Licensing officers will check that the provision of non-mechanical ramps is being maintained by the vehicle proprietor), and
- Where fittings are used to secure wheelchairs to the floor of a vehicle, provide a certificate/report confirming that all the fittings are intact and are free from damage and wear

3c.64 Once an application has been validated and accepted, the Council will:

- Complete an online check of the MOT history for the vehicle
- Where applicable, make enquiries through the Councils adults and childrens social care teams, West Mercia Police (or other relevant force), other local authorities and any other organisation, agency or person that the Council has deemed appropriate to seek information from

3c.65 **NB** For partnerships or companies, the requirements set out in paragraphs 3c.5 to 3c.20 apply to all partners and directors/company secretaries.

3c.66 Where an application is received to change the proprietor of a private hire vehicle licence (transfer of licensee), the new proprietor must fulfil the requirements as set out in paragraphs 3c.5 to 3c.20 above.

3c.67 Providing the above are satisfied, Officers will grant the licence. In all other cases, the application will be referred to the Licensing Panel for determination. Each application will be decided on its merits. However, there is a presumption that unless an applicant can demonstrate exceptional circumstances the application will be refused. Whilst it is neither possible nor prudent to draw up a list of what might amount to exceptional circumstances, an applicant who claims that exceptional circumstances exist will be expected to be able to satisfy the Council that it would not frustrate the purposes of this Policy or compromise public safety if the licence were granted. The applicant will be notified in writing if their application is to be determined at a meeting of the Licensing Panel.

MOT requirements¹⁵

3c.68 MOTs are required in accordance with the following requirements:

- Vehicles, up to 9 years from date of first registration, must be submitted for an MOT inspection at 6-monthly intervals (and any other inspection deemed necessary by an authorised officer) and the applicant must produce valid MOT certificates to the Council in this respect.

¹⁵ The requirement to submit an MOT will be in accordance with section 50 of the Local Government (Miscellaneous Provisions) Act 1976

- Once a vehicle reaches the age of 9 years, in addition to the MOT certificate submitted with an application, it must have two other MOT tests per year; tests being spaced evenly throughout the year at four monthly intervals and the applicant must produce valid MOT certificates to the Council in this respect.
- MOT certificates will only be accepted by the Council within 10 working days of the date of issue from the MOT testing centre.
- MOTs must be undertaken by a 'Nominated Tester' or Authorised Vehicle Examiner at a Vehicle Testing Station appointed under Section 45 of The Road Traffic Act 1988; the cost of all tests must be met by the vehicle proprietor.
- The vehicle must have a valid MOT throughout the licence period.

3c.69 The Council will check the MOT history of a licensed vehicle to ensure that the vehicle has not been used to fulfil any private hire work on a failed MOT where the vehicle has failed for dangerous (do not drive until repaired) defects or category major (repair immediately) defects.

3c.70 With respect to a licensed vehicle, in the event that a proprietor fails to present to the Council an MOT test certificate as required (unless delayed or prevented by sufficient cause accepted and agreed by the Council), the Council may suspend the licence and require the proprietor of that private hire vehicle to return all the plates to the Council subject to any appeal period.

MOT failures and advisories

3c.71 The Councils position in regards to MOT failures and advisories is as follows:

- Where a vehicle fails an MOT under the category dangerous (do not drive until repaired) defects, DVSA guidance states that this will have a direct and immediate risk which will put passengers and other road users at risk or have a serious impact on the environment. The Council requires all repairs to be undertaken and a new MOT test certificate issued before the vehicle is used as a private hire vehicle.
- Where a vehicle fails an MOT under the category major (repair immediately) defects, the Council has a concern for the vehicle safety which may put passengers and other road users at risk or have an impact on the environment. The Council requires all repairs to be undertaken and a new MOT test certificate issued before the vehicle is used as a private hire vehicle.

3c.72 Where a proprietor permits a vehicle that has failed an MOT for dangerous (do not drive until repaired) defects, or major (repair immediately) defects, to be used as a private hire vehicle, the licence will be referred to the Licensing Panel for review where an officer with delegated authority will consider each case on its own individual merits and will determine what action is appropriate and proportionate to the circumstances of the case.

3c.73 Shropshire Council reserves the right to require proprietors to rectify any items listed under minor or advisory information on an MOT certificate and to provide evidence that the work has been completed to the Council within a timescale specified by the Council. In the event that a proprietor fails to rectify any items requested by the Council (unless delayed or prevented by sufficient cause accepted and agreed by the Council), the Council may suspend the licence and require the proprietor of that hackney carriage to return all the plates to the Council subject to any appeal period.

Insurance

3c.74 Certificates of insurance are required in accordance with the following requirements:

- The vehicle must have a valid certificate of insurance for private hire including proof of Public Liability insurance for a minimum of £5,000,000, throughout the licence period. Insurance stating covered for public hire will not be accepted for private hire vehicles.
- Certificates of insurance or cover notes issued to cover “any vehicle” or “any driver” must be accompanied by a schedule showing all the vehicles and drivers covered by the insurance as detailed in the certificate of insurance.
- Where a vehicle is insured by a proprietor and the proprietor allows another licensed Shropshire Council driver to drive their vehicle, or any vehicle is insured under a fleet insurance, the proprietor (as the policy holder) is responsible for ensuring that the driver of that vehicle is aware of the content of the policy, including its limitations and exclusions, and that the proprietor keeps records to this effect.
- Where an insurance cover note is provided a full certificate of insurance must be produced to the Council within 7 days of the certificate being received by the owner of the vehicle.
- The proprietor must also obtain information as to any requirement for them to have Employers Liability Indemnity; if there is such a requirement, it must be for a minimum of £1,000,000.

3c.75 With respect to a licensed vehicle, in the event that a proprietor fails to present to the Council a valid certificate of insurance as required (unless delayed or prevented by sufficient cause accepted and agreed by the Council), the Council may suspend the licence and require the proprietor of that private hire vehicle to return all the plates to the Council subject to any appeal period.

Vehicle compliance process

3c.76 Once an application has been validated and accepted a member of the Licensing Team will contact the applicant to arrange a vehicle compliance appointment. At the appointment a vehicle will be subject to a compliance check to ensure:

- That where the vehicle is sufficiently equipped for the provision of one reference wheelchair that the driver presenting the vehicle is capable of safely loading and securing the wheelchair into the vehicle (the vehicle, including seating, wheelchair restraint and ramp, will be photographed and the images held on the vehicle record file for future reference)
- That where fitted the meter seal is intact and the serial number matches the number provided in the meter calibration certificate. Where a meter seal has been tampered with and/or the serial number no longer matches a new certificate/report to confirm the vehicle is fitted with a taximeter in accordance with the requirements set out at paragraph 3c.46
- The vehicle has a full size spare wheel or space saver design wheel and the tools to change a wheel OR a contract with a mobile tyre replacement specialist
- At least one no smoking sign is on display in the vehicle
- That where a vehicle is wheelchair accessible a sign confirming the wheelchair accessibility is clearly displayed
- The drivers internal ‘Vehicle Copy’ of drivers badge is displayed ensuring that the licence details and photo are visible to passengers
- Where CCTV is fitted, a CCTV operating in this vehicle sign is on display in the vehicle

3c.77 Vehicle proprietors are required to return the existing licence plate (renewal/transfer vehicles only) at the compliance appointment. Where officers are satisfied that the vehicle meets the compliance checks, the new licence plates will be issued. If, however, the vehicle does not meet the compliance check, advice will be provided and a further appointment arranged.

Transfer of a licence (Change of vehicle)

3c.78 All requests to transfer a vehicle licence (change of vehicle) onto another vehicle will be treated as a new vehicle application (in accordance with the requirements set out at paragraphs 3c.36 to 3c.42).

3c.79 Where a proprietor has notified the Council that damage has occurred to a licensed vehicle, resulting in the transfer of licence to a temporary insurance replacement vehicle, proprietors will be required to provide evidence to demonstrate the damage which has occurred to the vehicle, i.e. insurance assessors report.

3c.80 Where a wheelchair accessible vehicle has sustained structural damage from a road traffic accident resulting in a DVLA classification under Category S – Structural damage (vehicle that has sustained damage after 1 October 2017) or Category C (vehicle has sustained damage, rendering it beyond economical repair, prior to 1 October 2017), any documents provided to meet the safety requirements of the policy as part of the previous application process (i.e. VCA certificate, IAC or IVA 6) may be invalid. In these circumstances the Council will require the proprietor to submit the vehicle for a new basic voluntary IVA check and provide a valid IVA 6 certificate to the Licensing Team before the licence can be transferred back to the original vehicle.

3c.81 Where a wheelchair accessible vehicle has sustained damage that does not affect the validity of the documents provided to meet the safety requirements of the policy as part of the previous application process (i.e. VCA certificate, IAC or IVA 6), provided any repairs have been made by a garage approved and authorised by the insurance company, the Council will require the proprietor to submit confirmation from the insurance company that the repairs have been completed in accordance with the insurance assessors report and a new MOT certificate (in accordance with the requirements set out at paragraph 3c.68 above) to the Licensing Team before the licence can be transferred back to the original vehicle.

Vehicle not fit for the conveyance of passengers

3c.82 Where a proprietor has notified the Council that damage has occurred to a vehicle, otherwise than in accordance with relevant road traffic legislation, the Council may require photographic evidence of the damage or for the vehicle to be presented for inspection by an authorised officer of the Council.

3c.83 If the authorised officer determines that a vehicle is not fit for the purpose of conveying passengers an authorised officer of the Council may at that time suspend the licence and require the proprietor of the vehicle to return all the vehicles plates to the Council. The suspension will be lifted and the plate returned at such time when the condition of the vehicle is demonstrated, to the satisfaction of the Council, to be fit for conveying passengers.

3c.84 The officer may require the proprietor to arrange for a further MOT test, or in respect of wheelchair accessible vehicles a basic voluntary IVA test, to be undertaken and certificate produced before the vehicle will be permitted to operate; this is at the discretion of the authorised officer.

Use of information on and in relation to private hire vehicles

- 3c.85 Proprietors may display advertisements, information, images and other material on private hire vehicles in accordance with the conditions set out at **Appendix L**. This is subject to prior written approval from the Council.
- 3c.86 Proprietors are encouraged to display an operator's name and/or trade name, as approved by the Council.

Closed circuit television (CCTV)

- 3c.87 Proprietors of private hire vehicles are encouraged to install closed circuit television (CCTV) systems providing such systems are installed in accordance with the appropriate legal framework and the Council has been notified, in writing, of their intention to do so.
- 3c.88 Proprietors of private hire vehicles must register with the Information Commissioners Office (ICO) and maintain a valid registration throughout the duration of the licence or until such a time as the CCTV has been removed from the licensed vehicle.

Trailers

- 3c.89 Private hire vehicles licensed by the Council are permitted to tow trailers when undertaking the licensed activity providing that the conditions set out at **Appendix M** are complied with at all times.

Parking/waiting

- 3c.90 Where a driver is illegally parked or creating an obstruction, i.e. in contravention of road traffic legislation and traffic regulation orders (this does not include a legitimate period of time where a private hire vehicle has stopped to drop off or pick up a fare), the driver's licence may be reviewed and such conduct may be deemed a reasonable cause to revoke or suspend the licence or to take any other appropriate action.

LPG converted vehicles

- 3c.91 The Council must be satisfied that any vehicle that has been converted to LPG has been converted correctly prior to a licence being issued. To this end, the Council will undertake checks with the UK LPG Vehicle Register.
- 3c.92 With respect to new applications, where it is established that a conversion has not been undertaken correctly and/or the vehicle is unsafe in any way, the Council will refuse the application.
- 3c.93 In the event that an LPG conversion has been undertaken on a vehicle during a current licensed period and the proprietor of the vehicle fails to notify the Council within 7 days of the conversion, an authorised officer of the Council will suspend the vehicle licence until such time as evidence is available on the UK LPG Vehicle Register.
- 3c.94 In the case of a conversion that has been undertaken on a vehicle during a current licensed period and it is subsequently established that the conversion has not been undertaken correctly and/or

the vehicle is unsafe in any way, an authorised officer of the Council will suspend the vehicle licence until such time as the conversion has been undertaken correctly and/or it is demonstrated to the satisfaction of the Council that the vehicle is safe.

Production of records/documents

3c.95 Any records required to be retained in accordance with the licence and licence conditions must be produced, on request, to any authorised officer of the Council or to any police officer.

Licence conditions

3c.96 The applicable conditions relevant to a private hire vehicle licence are set out at **Appendix D**; these conditions must be complied with. These conditions are in addition to any matters set out within the main body of the Policy.

Main legal requirements

3c.97 Paragraphs 3c.98 to 3c.105 is not exhaustive and unless otherwise specified please refer to the Local Government (Miscellaneous Provisions) Act 1976 for a full list of legal requirements, offences and the maximum penalty upon conviction.

3c.98 Change of proprietor

The proprietor must give notice to the Council of any transfer in his interest in the private hire vehicle to a person other than the proprietor whose name is specified in the licence. Such notice must be given, in writing, within 14 days specifying the name and address of the person to whom the vehicle has been transferred.

3c.99 Inspection

The proprietor must present their private hire vehicle for inspection and testing by the Council as required, up to a maximum of 3 times during any one period of 12 months.

3c.100 The proprietor must provide, on request, the address where the private hire vehicle is kept and allow the Council to inspect and test the vehicle at that address.

3c.101 Accidents

The proprietor, notwithstanding their responsibilities under relevant road traffic legislation, must also report to the Council any accident as soon as reasonably practicable. However, where the vehicle has suffered accident damage that materially affects the safety, performance or appearance of the vehicle, or the comfort or convenience of fare paying passengers, the driver must notify the Council within 72 hours.

3c.102 Production of documents

The proprietor must, on request by an authorised officer of the Council or a police officer, produce to the officer for inspection the private hire vehicle licence and insurance certificate within 7 days.

3c.103 Return of identification plates

Where a licence is revoked, suspended or expires, the proprietor, when required by the Council to do so must return the all identification plates within 7 days.

3c.104 Transporting children

As a minimum, private hire vehicles must be capable of complying with the requirements set out in the table below, for further guidance see <https://www.gov.uk/child-car-seats-the-rules/when-a-child-can-travel-without-a-car-seat>.

	Front seat	Rear seat	Who is responsible?
Child up to 3 years	Correct child restraints must be used	Correct child restraint must be used. If a restraint is not available in a licensed hackney carriage or private hire vehicle, the child may travel unrestrained.	Driver**
Child from 3rd birthday to 12th birthday or 135 cm in height whichever they reach first	Correct child restraints must be used	Where seat belts are fitted, the correct child restraint must be used. The child must use adult belt if the correct child restraint is not available as follows: in a licensed hackney carriage or private hire vehicle; or for a short distance in an unexpected necessity; or two occupied child restraints prevent fitting of a third. A child 3 years and over may travel unrestrained in the rear seat of a vehicle if seat belts are not fitted in the rear.	Driver**
Child over 135 cm in height or 12 or 13 years old	Seat belt must be worn if available*	Seat belt must be worn if available.	Driver**
Passengers aged 14 years and over	Seat belt must be worn if available*	Seat belt must be worn if available.	Passenger

*Vehicles built before 1965 are not required to have fitted seatbelts.

**Drivers must inform parents/carers that the decision to permit children to travel in the vehicle, without the correctly sized seat restraints (as permitted by relevant legislation) and with the obvious risks associated with such an action, remains with the parent/carer responsible for the children and not with the driver of the vehicle.

3c.105 Ranks/stands

A private hire vehicle must not wait (stop or park) on any rank/stand.

Summary

- 3d.1 Executive private hire vehicles are licensed in accordance with the provisions of the Local Government (Miscellaneous Provisions) Act 1976. Section 75(3) provides for the Council to issue an exemption notice. The Council will only consider an exemption where the applicant can demonstrate that the requirements of this section are fully satisfied. Executive private hire vehicles must not have the appearance of a hackney carriage or a standard private hire vehicle.
- 3d.2 When considering whether a vehicle is an executive private hire vehicle, by the nature of the work it does, Shropshire Council shall have regard to the document Private Hire Vehicle Licensing - A note for guidance from the Department for Transport (August 2011).
- 3d.3 The Council legally cannot limit the number of executive private hire vehicle licences that it will issue.
- 3d.4 The Council will not licence a vehicle for hire and reward which is licensed by another local authority or allow or permit a private hire vehicle identification plate issued by another authority to be displayed on the vehicle.

Business model for executive private hire vehicles

- 3d.5 Executive private hire vehicles must only be used for executive service, which is defined as the provision of a vehicle or vehicles that is/are **exclusively** used for executive private hire work and **not** for 'normal' or general purpose private hire use.
- 3d.6 The type of work that is considered 'executive service' includes, but is not restricted to:
- Exclusive business to business contracts, i.e. to transport employees and clients on business related journeys under a written contract to a company or person.
 - Bookings for certain clients (for example politicians and celebrities) who, for security or personal safety reasons, would not want the vehicle to be identifiable as a private hire vehicle.
 - Bookings for certain clients who want to hire an executive vehicle at a premium rate, where the applicant can demonstrate that the vehicle is used solely for the purposes of this type of hire.
- 3d.7 Bookings taken in respect of clients who require an executive private hire must be paid for on account. No payment can be made to the driver of the vehicle at time of hiring.
- 3d.8 Applicants must be able to demonstrate the vehicle will be used for executive service by:
- Providing written confirmation from their private hire operator that the vehicle will only undertake executive service.
 - Providing written confirmation that the vehicle will be used solely for executive service and not for 'normal' or general private hire use.

Applicant

- 3d.9 The applicant for a vehicle licence must be the person who is the legal owner of the vehicle concerned and entitled to have ownership of the vehicle¹⁶.

Fit and proper person

- 3d.10 The proprietor of a licensed executive private hire vehicle provides a public service that impacts on public safety. On this basis, the Council will not licence a vehicle as an executive private hire vehicle unless it is satisfied that the proprietor of the vehicle meets all the criteria to be deemed a fit and proper person as set out in **Appendix I**.

Proprietors who apply for an executive private hire vehicle licence and who hold a valid Shropshire Council hackney carriage/private hire drivers licence or a valid Shropshire Council private hire operator licence

- 3d.11 The Council adopts the same principles when determining whether an applicant is a fit and proper person to hold a vehicle licence as it does to persons applying for a drivers licence. In this respect, applicants are required to have due regard, as appropriate, to the requirements and information set out at paragraphs 3a.4 to 3a.24 of the Policy.

Proprietors who apply for an executive private hire vehicle licence and who do not hold a valid Shropshire Council hackney carriage/private hire drivers licence or a valid Shropshire Council private hire operator licence

- 3d.12 In considering the fit and proper person test, all applicants on initial application must provide a basic criminal record disclosure from the Disclosure and Barring Service. All applicants on renewal must provide a basic criminal record disclosure that has been issued by the Disclosure and Barring Service within the previous 12 months of the date that the application is received by the Council. On new and renewal applications the Council will also make additional enquiries through its adults and childrens social care teams, directly with West Mercia Police (and other relevant police forces, where appropriate), other relevant local authorities (particularly Telford & Wrekin Council and City of Wolverhampton Council) and any other appropriate organisation, agency or person in order to ensure the Council is in a position to make as accurate an assessment of the applicant's fitness to hold a licence as is reasonably practicable.
- 3d.13 With specific reference to existing licence holders, where there is any cause for a licence to be reviewed, the Council will make additional enquiries through its adults and childrens social care teams, directly with West Mercia Police (and other relevant police forces, where appropriate), other relevant local authorities (particularly Telford & Wrekin Council and City of Wolverhampton Council) and any other appropriate organisation, agency or person in order to ensure the Council is in a position to make as accurate an assessment of the licence holders fitness to hold a licence as is reasonably practicable. Depending on the circumstances of the case, the Council may request the licence holder to consent to a further basic criminal record disclosure, the cost of which lies with the licence holder. Where a licence holder refuses to consent to a further check the Council will take this into consideration in determining their continuing fitness to hold a licence.
- 3d.14 When assessing the fitness of an applicant to hold an executive private hire vehicle proprietors licence, the Council will consider the applicant's criminal history as a whole, together with all other

¹⁶ There is no legal definition of proprietor within relevant legislation, however, the Council has taken the view that proprietor means the legal owner based on common usage of the term.

relevant evidence, information and intelligence including their history (e.g. complaints and positive comments from the public, compliance with licence conditions and willingness to co-operate with licensing officers) whilst holding a licence from the Council or any other authority. Particular attention will be given to patterns of behaviour, irrespective of the time-scale over which they have occurred, both in terms of proven criminal offences and other behaviour/conduct that may indicate the safety and welfare of the public may be at risk from the applicant.

- 3d.15 In addition, an important element associated with the fitness to hold a licence is the appearance and behaviour of an applicant. Consequently, the Council requires all applicants to maintain a reasonable standard of appearance and behaviour when in contact and dealing with all persons, including but not limited to, other road users, pedestrians, customers, the general public, other licensed operators and drivers of hackney carriage and private hire vehicles, Council officers and elected members at all times. Applicants must also co-operate with any reasonable request made by an authorised officer of the Council or any police officer.
- 3d.16 It must also be recognised that the Council will consider all relevant criminal history, behaviour and conduct irrespective of whether the specific history, behaviour or conduct occurred whilst applicants were directly engaged in hackney carriage or private hire licensed work at the time or whether they occurred during the applicants' own personal time. The Council considers a person or individual who has a propensity to commit offences and/or demonstrate unacceptable conduct whilst not engaged in hackney carriage or private hire work to be equally as serious as offences and/or unacceptable conduct committed whilst engaged in hackney carriage or private hire work.

Criminal record disclosure

- 3d.17 All unspent convictions, including cautions, will be taken into account when considering a person's suitability to hold a licence. Consequently, applicants are required to provide details of all unspent convictions and cautions, including driving endorsements (driving convictions) and disqualification periods relating to traffic offences.
- 3d.18 Although cautions are generally not as serious as convictions, ordinarily as a result of the circumstances under which they are offered, they do require an admission of guilt before they can be issued which is equivalent to a guilty plea on prosecution. Consequently, a caution is regarded in exactly the same way as a conviction. Fixed penalties, community resolutions or similar sanctions will also be considered in the same way as a conviction on the basis that payment of a fixed penalty indicated an acceptance of guilt and a community resolution can only be imposed following an admission of guilt. As a result, each of these sanctions is a valuable indication as to an applicant's character and whether they are a fit and proper person to hold or be granted a licence.
- 3d.19 A criminal record does not automatically bar an applicant from holding a licence; however, it will be a significant factor when determining whether a licence ought to be granted or not. Where an applicant has previous criminal convictions, these will be considered in line with the guidance set out in **Appendix I**. However, the over-riding consideration will always be to ensure the safety and welfare of the public.
- 3d.20 Persons who have not been resident within the United Kingdom for the five years prior to submitting an application, will be required to produce a certificate of good conduct or equivalent document (at their own cost) issued by the relevant Embassy or High Commission. The certificate must be authenticated, translated and sealed by the Embassy or High Commission. In the event that an applicant is not able to obtain a certificate of good conduct, they may submit a statutory

declaration with regard to their conduct, which must be completed in the presence of a practising solicitor. The Council may contact the relevant Embassy, High Commission, solicitor or other appropriate body to verify any documents provided. Contact details for Embassies and High Commissions can be found from the Foreign, Commonwealth & Development Office (FCDO) on the GOV.UK website at <https://www.gov.uk/government/world>. The FCDO may be contacted for further assistance by telephone on 020 7008 5000, by email at fcdo.correspondence@fcdo.gov.uk or by post at the FCDO, King Charles Street, London, SW1A 2AH.

- 3d.21 Applicants who have spent three continuous months or more living outside the United Kingdom, during the period of their licence, will be required to produce a certificate of good conduct or equivalent document (at their own cost). This certificate must be issued by the relevant Embassy or High Commission for the country or countries lived in during this period and meet the requirements as set out at 3d.20 above. It is recognised that some countries will not provide a certificate of good conduct unless the individual has been resident for six months or more. Where a relevant Embassy or High Commission refuse to issue a certificate of good conduct, applicants must provide written confirmation from the Embassy of any refusal to the Licensing Team.

Non-conviction information

- 3d.22 In addition to conviction/caution information, applicants are expected to provide details, within 48 hours of all warnings, driving endorsements (driving convictions)/disqualification periods relating to traffic offences, fixed penalties, community resolutions and any other similar sanctions, together with any charges or arrests that they are the subject of in connection with criminal offences, whether or not actually charged with the offence, and details of any allegations of involvement in criminal activity or where they have been questioned in connection with any alleged criminal activity or inappropriate/unacceptable behaviour or any other relevant pending matter.
- 3d.23 Where an applicant is the subject of an outstanding charge or summons, their application may continue to be processed; however, depending on the circumstances, it is unlikely that a decision on the application will be made until the conclusion of the criminal proceedings. Where the outstanding charge or summons involves a serious offence and/or the individual's offending history and behaviour/conduct indicates a pattern of unlawful or unacceptable behaviour/character traits, then the application is likely to be refused.
- 3d.24 Where there is evidence/information that an applicant has been arrested or charged but not convicted of offences and the nature of this evidence/information suggests the applicant may not be a fit and proper person, the Council will give serious consideration to refusing an application or revoking an existing licence.

Period of licence

- 3d.25 Vehicle licences will be issued for a maximum period of 12 months.

Vehicle licence plates

- 3d.26 The external rear plate and the internal plate, identifying the vehicle as an executive private hire vehicle, show the licence details on a gold background with the Shropshire Council logo.

Vehicle specification

- 3d.27 The Council requires executive private hire vehicles to comply with the following requirements:
- 3d.28 The Council does not provide a list of specific vehicles that it will definitely consider appropriate to be licensed as executive private hire vehicles. However, any vehicle being plated as an executive vehicle must be classed as a large family vehicle, be of saloon, estate, hatchback or people carrier type.
- 3d.29 Relevant considerations as to whether a vehicle meets an executive standard include, but are not limited to, cost, reputation, specification, appearance, perception, superior comfort levels and seating specification, e.g., whether the vehicle offers additional space per passenger compared to standard vehicles.
- 3d.30 Applicants considering applying for an executive plate are strongly advised to contact the licensing team in advance of purchasing any vehicle to ensure it is appropriate to be licensed.
- 3d.31 Executive private hire vehicles must comply with the following requirements:
- Be in immaculate condition, in a uniform colour, with no visible defects and free from dents, scratches or rust to the external bodywork or internal trim and seating
 - Have high level interior trim and leather seating
 - Be large enough to carry at least 3 adult passengers and their luggage
 - Have air conditioning or climate control
 - Have alloy wheels
 - Be maintained to a very high standard
- 3d.32 In addition:
- The passenger capacity will be restricted to the number of seats for adults
 - Council executive plates must be displayed
 - The sale of alcohol in the vehicle must be covered by a separate licence in accordance with the Licensing Act 2003 (for further information please contact the Councils Licensing Team)
 - The advertising or display of information, images and other material in or on an executive vehicle is prohibited
 - A taxi meter must not be fitted

Emissions/Age Restrictions

- 3d.33 Vehicles that are **not** wheelchair accessible vehicles must comply with the following:

Renewal/New Application	Fuel	Period	European Emission / Age Standard
New	Petrol	1 April 2023 to 31 March 2024	Euro 5
New	Petrol	1 April 2024 to 31 March 2028	Euro 5 and where the vehicle is less than 10 years old

			from date of first registration
New	Diesel	1 April 2023 to 31 August 2025	Euro 6/Euro 6d and where date of first registration is on or after 1 September 2016
New	Diesel	1 September 2025 to 31 March 2028	Euro 6 / Euro 6d and where the vehicle is less than 6 years old from date of first registration
New	Full electric	1 April 2023 to 31 March 2028	Any age
New	Hybrid petrol	1 April 2023 to 31 March 2028	less than 10 years old from date of first registration
New	Hybrid diesel	1 April 2023 to 31 March 2028	less than 8 years old from date of first registration
New	LPG	1 April 2023 to 31 March 2028	less than 10 years old from date of first registration
Renewal	Petrol	1 April 2023 to 31 March 2024	Euro 5
Renewal	Petrol	1 April 2024 to 31 March 2028	Euro 5 and where the vehicle is less than 12 years old from date of first registration
Renewal	Diesel	1 April 2023 to 31 March 2025	Euro 5 / Euro 6 / Euro 6d and where the vehicle is less than 10 years old from date of first registration
Renewal	Diesel	1 April 2025 to 31 March 2028	Euro 6 / Euro 6d and where the vehicle is less than 10 years old from date of first registration
Renewal	Full electric	1 April 2023 to 31 March 2028	Any age
Renewal	Hybrid petrol	1 April 2023 to 31 March 2028	less than 12 years old from date of first registration

Renewal	Hybrid diesel	1 April 2023 to 31 March 2028	less than 10 years old from date of first registration
Renewal	LPG	1 April 2023 to 31 March 2028	less than 12 years old from date of first registration

3d.34 The following is applicable to **wheelchair accessible vehicles only**. Vehicles that **are** wheelchair accessible vehicles must comply with the following:

Renewal/New Application	Fuel	Period	European Emission / Age Standard
New	Petrol	1 April 2023 to 31 March 2024	Euro 5
New	Petrol	1 April 2024 to 31 March 2028	Euro 5 and where the vehicle is less than 12 years old from date of first registration
New	Diesel	1 April 2023 to 31 August 2025	Euro 6/Euro 6d and where date of first registration is on or after 1 September 2016
New	Diesel	1 September 2025 to 31 March 2028	Euro 6 / Euro 6d and where the vehicle is less than 6 years old from date of first registration
New	Full electric	1 April 2023 to 31 March 2028	Any age
New	Hybrid petrol	1 April 2023 to 31 March 2028	less than 12 years old from date of first registration
New	Hybrid diesel	1 April 2023 to 31 March 2028	less than 10 years old from date of first registration
New	LPG	1 April 2023 to 31 March 2028	less than 12 years old from date of first registration
Renewal	Petrol	1 April 2023 to 31 March 2024	Euro 5
Renewal	Petrol	1 April 2024 to 31 March 2028	Euro 5 and where the vehicle is less than 15 years old from date of first registration

Renewal	Diesel	1 April 2023 to 31 March 2025	Euro 5 / Euro 6 / Euro 6d and where the vehicle is less than 12 years old from date of first registration
Renewal	Diesel	1 April 2025 to 31 March 2028	Euro 6 / Euro 6d and where the vehicle is less than 12 years old from date of first registration
Renewal	Full electric	1 April 2023 to 31 March 2028	Any age
Renewal	Hybrid petrol	1 April 2023 to 31 March 2028	less than 15 years old from date of first registration
Renewal	Hybrid diesel	1 April 2023 to 31 March 2028	less than 12 years old from date of first registration
Renewal	LPG	1 April 2023 to 31 March 2028	less than 15 years old from date of first registration

NB The charts above provide information for the licensing of vehicles up to 31 March 2028 and the maximum age for a vehicle to remain licensed. The Council does not currently intend to make any changes in the future to reduce the maximum age for a vehicle to remain licensed where a vehicle had already been licensed before 31 March 2028. However, the Policy will be subject to continuous evaluation and, if necessary, can be formally reviewed at any time.

Safety

3d.35 The Council will not licence any new vehicle that since the date of first registration has been recorded by the DVLA as having sustained structural damage resulting from a road traffic accident (an insurance 'Write Off' under the DVLA's Category S – Structural damage classification for vehicle that has sustained damage after 1 October 2017 or Category C where a vehicle has sustained damage, rendering it beyond economical repair, prior to 1 October 2017). This information can be found in the Special Notes section of the V5 registration Certificate.

3d.36 Vehicles must meet the following safety standards as defined by the European New Car Assessment Programme (NCAP). In this respect, the Overall Rating must be used. Where the Overall Rating is not available, the Adult Rating is the relevant standard:

- All new vehicle applications submitted on or after 1 April 2023 are required to be NCAP 5 star.
- All renewal vehicle applications submitted on or after 1 April 2023 are required to be NCAP 5 star.

NB Applicants wishing to purchase a new vehicle that meets the requirements of the age/emissions section of this Policy, however, to which no NCAP safety rating has been applied, are advised to contact the Council for advice prior to purchase. An application may be considered

if the applicant is able to demonstrate exceptional circumstances to satisfy the Council that it would not frustrate the purposes of this Policy or compromise public safety if the licence were granted.

3d.37 The requirements of 3d.36 do not apply to private hire vehicles that have been specifically constructed or converted for disability access and any M1 (not M2 or N1) vehicle that has been adapted to be a private hire vehicle (and has been accepted by an authorised officer of the council to be licensed only as a private hire vehicle) where:

- The vehicle has come off the production line as a purpose-built wheelchair accessible vehicle there will be a Vehicle Certification Agency (VCA) certificate which demonstrates that the vehicle has been constructed to an acceptable safety standard, providing there have been no changes to the layout of the vehicle since the VCA was issued.
- The vehicle is modified after production, but before first registration, there may be an Individual Approval Certificate (IAC) available, which will demonstrate that the adaptations have been tested by DVSA (VOSA) and are to an acceptable safety standard, providing there have been no changes to the conversion since the IAC was issued. This may be referred to as a Statutory Individual Vehicle Approval.
- Vehicles that are converted for disability access after first registration have been submitted for a Basic Voluntary IVA (Individual Vehicle Approval). This is the route that vehicles are required to take where there is no VCA certificate or IAC available. Vehicles must be presented to the DVSA for a Basic Voluntary IVA inspection Class P – Personal Import. If the vehicle passes the inspection it will receive a Certificate of Compliance (IVA 6). The Voluntary IVA checks the whole of the vehicle, not only the parts that have been converted and is similar to a very strict MOT test.

3d.38 Where a proprietor has notified the Council that a licensed vehicle has sustained structural damage from a road traffic accident resulting in a DVLA classification under Category S – Structural damage (vehicle that has sustained damage after 1 October 2017) or Category C (vehicle has sustained damage, rendering it beyond economical repair, prior to 1 October 2017), any documents provided to meet the safety requirements of the policy as part of the previous application process (i.e. NCAP safety report or IVA certificate) will be invalid. The proprietor will be required to submit the vehicle for a new voluntary IVA check and provide a valid IVA certificate to the Licensing Team.

List of Designated Wheelchair Accessible Vehicles

3d.39 Section 167 of the Equality Act 2010 requires all local authorities to maintain a list of designated wheelchair accessible vehicles.

3d.40 All wheelchair accessible vehicles must be capable of transporting the user of a “reference wheelchair” and will be included within the Council’s list of designated vehicles. Specifications for a “reference wheelchair” can be found at **Appendix J**.

3d.41 Section 172 of the Equality Act 2010 provides for an appeal to be made against the decision to include a vehicle on the list of designated wheelchair accessible vehicles. Any appeal must be made to the Magistrates Court within 28 days of the vehicle being included on the list.

- 3d.42 Proprietors have a responsibility to ensure that any Shropshire Council licensed driver who drives one of their wheelchair accessible vehicles is made aware of their duties in respect of carrying disabled persons in wheelchairs when driving a designated wheelchair accessible vehicle.
- 3d.43 Failure to comply with the duties listed under section 165 of the Equality Act 2010 is a criminal offence.

Other Requirements

- 3d.44 Vehicles must not seat more than eight passengers (not including the driver) and:
- (a) Be a Light Passenger Vehicle as defined by section 85 of the Road Traffic Act 1988 and have a minimum of 4 wheels
 - (b) Provide sufficient means by which any person in the carriage may communicate with the driver
 - (c) Have a watertight roof or covering
 - (d) Provide at least two windows on each side of the vehicle of which one window on one side must have a means of opening/closing
 - (e) Tinted windows will only be permitted in accordance with the manufacturers or specialist coachbuilder's specification and must comply with the Road Vehicles (Construction & Use) Regulations 1986 as amended. The Council will not permit any form of additional film to darken or tint the glass on any part of the vehicle
 - (f) Have seats that are properly cushioned and covered
 - (g) Have a floor provided with a proper carpet, mat, or other suitable covering
 - (h) Have fittings (including fittings that are used to secure wheelchairs to the floor of the vehicle) and furniture in a clean condition and be well maintained and in every way fit for executive service
 - (i) Provide means for securing luggage if the carriage is so constructed as to carry luggage
 - (j) Where tilting passenger seats are fitted the seat must:
 - Be forward facing (with the exception of the fold down seats fitted onto the bulkhead/partition of a purpose-built vehicle)
 - Designed for use by an adult
 - Have a three point seatbelt
 - (k) Have a minimum of four passenger doors including an entry/exit point for the driver
 - (l) Be maintained in a sound mechanical and structural condition at all times
 - (m) Have a full size spare wheel or space saver design wheel and the tools to change a wheel OR a contract with a mobile tyre replacement specialist (in any event where a spare wheel has been used, it is only to permit the current fare to be completed and any defective wheel must be replaced before taking another fare to ensure passenger safety); all pneumatic tyres, including the spare, must comply with the vehicle manufacturer's specification and any relevant legislation
 - (n) Be maintained in a clean and safe condition at all times from both exterior and interior perspectives
 - (o) Proprietors are encouraged to have provision for the legal transportation of a minimum of one "reference wheelchair" at all times. Specifications for a "reference wheelchair" can be found at **Appendix J**
 - (p) When transporting a wheelchair user, where a seat has to be removed in order to accommodate a passenger in a wheelchair, proprietors must store the seat securely away from the passengers and driver (e.g. in the boot or other suitable storage facility away from the vehicle)

- (q) Where a mechanical ramp is fitted, comply with requirements of the Lifting Operations and Lifting Equipment Regulations 1998
- (r) Where a non-mechanical ramp is fitted, comply with the relevant provisions of the Provision and Use of Work Equipment Regulations 1998
- (s) When transporting a wheelchair user, where the wheelchair user chooses to transfer to a passenger seat, proprietors must store the wheelchair securely away from the passengers and driver (e.g. in the boot)

New application process

- 3d.45 The application form must be fully completed and include all relevant information, supporting documentation and appropriate fee.
- 3d.46 The full fee for the licence is payable at the time the application is submitted. (This includes any application to transfer a vehicle licence onto another vehicle)
- 3d.47 If any part of the application form is incomplete or the relevant information or supporting documentation is not provided, the applicant will be requested to provide the missing information/documentation and informed that the application will not be processed until such time as all the information/documentation is provided. If the applicant fails to provide all the information to complete the application, the application will be rejected.
- 3d.48 Once an application has been accepted by the Licensing Team as a valid application the application process must be completed within 6 months unless prevented from doing so by matters that are outside the applicant's control. When an application is not completed within this timescale the application will be referred to the Licensing Panel for determination where an officer with delegated authority will consider each case on its own individual merits and will determine what action is appropriate and proportionate to the circumstances of the case.
- 3d.49 Any person wishing to licence an executive private hire vehicle must:
- Submit a completed application form
 - Submit a completed reference form, unless the applicant is the holder of a hackney carriage and private hire drivers licence or private hire operator licence issued by Shropshire Council (NB the referees must be from either professional or business sources who have known the applicant for at least two years. In addition, the Council will not accept references from family members, drivers, operators, vehicle proprietors licensed with any local authority or, where relevant, the applicant's future employer unless there is satisfactory evidence of exceptional circumstances that are accepted by the Council). The Council reserves the right to refuse a reference where the Council deems the referee is not acceptable
 - Pay the appropriate licence fee
 - Provide written confirmation from their private hire operator that the vehicle will only undertake executive work, i.e. evidence of business to business contracts
 - Provide photographs to prove that the vehicle complies with the requirements of paragraphs 3d.27 to 3d.31 above
 - Provide a basic criminal record disclosure from the Disclosure and Barring Service, unless the applicant is the holder of a hackney carriage and private hire drivers licence or private hire operators licence issued by Shropshire Council (applicants can apply to <https://www.gov.uk/request-copy-criminal-record>). A basic criminal record disclosure will only be accepted by the Council within 12 months of the date of issue from the Disclosure and Barring Service

- Provide a valid MOT (in accordance with the requirements set out at paragraph 3d.55 below)
- Provide a valid certificate of insurance for private hire including proof of Public Liability insurance for a minimum of £5,000,000, insurance stating covered for public hire will not be accepted for private hire vehicles (in accordance with the requirements set out at paragraph 3d.59 below)
- Provide the full V5 registration certificate (note the alternative interim measure outlined in paragraphs 3d.61 to 3d.64)
- Provide evidence of compliance with the relevant European Emission/Age Standards as set out in paragraph 3d.33, or in the case of a wheelchair accessible vehicle as set out in paragraph 3d.34, either at the point of vehicle construction or by a subsequent adaptation or conversion approved by the Council - the compliance must be relevant to the engine installed in the vehicle and this must be reflected in the V5 registration certificate
- Provide evidence of compliance with the relevant European New Car Assessment Programme (NCAP) rating as set out in paragraphs 3d.35 to 3d.37
- Where the vehicle is fitted with a mechanically operated ramp, provide a valid certificate/report confirming the ramp complies with the requirements of the Lifting Operations and Lifting Equipment Regulations 1998 (NB The proprietor is responsible for ensuring that a competent person carries out the necessary checks in accordance with these Regulations.)
- Where non-mechanical ramps are used, provide confirmation from the proprietor of the vehicle that the ramps comply with the relevant provisions of the Provision and Use of Work Equipment Regulations 1998. (NB Licensing officers will check that the provision of non-mechanical ramps is being maintained by the vehicle proprietor.)
- Where fittings are used to secure wheelchairs to the floor of a vehicle, provide a certificate/report confirming that all the fittings are intact and are free from damage and wear

3d.50 Once an application has been validated and accepted, the Council will:

- Make enquiries through the Councils adults and childrens social care teams, West Mercia Police (or other relevant force), other local authorities and any other organisation, agency or person that the Council has deemed appropriate to seek information from
- Where applicable, write to the referees provided

3d.51 **NB** For partnerships or companies, the requirements set out in paragraphs 3d.9 to 3d.24 apply to all partners and directors/company secretaries.

3d.52 Where an application is received to change the proprietor of an executive private hire vehicle licence (transfer of licensee), the new proprietor must fulfil the requirements as set out in paragraphs 3d.9 to 3d.24 above.

3d.53 Paragraphs 3d.9 to 3d.24 above do not apply to applicants to transfer a vehicle licence onto another vehicle, on a temporary basis, by an accident management company.

3d.54 Providing the above are satisfied, Officers will grant the licence. In all other cases, the application will be referred to the Licensing Panel for determination. Each application will be decided on its merits. However, there is a presumption that unless an applicant can demonstrate exceptional circumstances the application will be refused. Whilst it is neither possible nor prudent to draw up a list of what might amount to exceptional circumstances, an applicant who claims that exceptional circumstances exist will be expected to be able to satisfy the Council that it would not

frustrate the purposes of this Policy or compromise public safety if the licence were granted. The applicant will be notified in writing if their application is to be determined at a meeting of the Licensing Panel.

MOT requirements¹⁷

3d.55 MOTs are required in accordance with the following requirements:

- Vehicles, up to 9 years from date of first registration, must be submitted for an MOT inspection at 6-monthly intervals (and any other inspection deemed necessary by an authorised officer) and the applicant must produce valid MOT certificates to the Council in this respect.
- Once a vehicle reaches the age of 9 years, in addition to the MOT certificate submitted with an application, it must have two other MOT tests per year; tests being spaced evenly throughout the year at four monthly intervals and the applicant must produce valid MOT certificates to the Council in this respect.
- MOT certificates will only be accepted by the Council within 10 working days of the date of issue from the MOT testing centre.
- MOTs must be undertaken by a 'Nominated Tester' or Authorised Vehicle Examiner at a Vehicle Testing Station appointed under Section 45 of The Road Traffic Act 1988; the cost of all tests must be met by the vehicle proprietor.
- The vehicle must have a valid MOT throughout the licence period.

3d.56 With respect to a licensed vehicle, in the event that a proprietor fails to present to the Council an MOT test certificate as required (unless delayed or prevented by sufficient cause accepted and agreed by the Council), the Council may suspend the licence and require the proprietor of that private hire vehicle to return all the plates to the Council subject to any appeal period.

MOT failures and advisories

3d.57 The Council's position in regards to MOT failures and advisories is as follows:

- Where a vehicle fails an MOT under the category dangerous (do not drive until repaired) defects, DVSA guidance states that this will have a direct and immediate risk which will put passengers and other road users at risk or have a serious impact on the environment. The Council requires all repairs to be undertaken and a new MOT test certificate issued before the vehicle is used as an executive private hire vehicle.
- Where a vehicle fails an MOT under the category major (repair immediately) defects, the Council has a concern for the vehicle safety which may put passengers and other road users at risk or have an impact on the environment. The Council requires all repairs to be undertaken and a new MOT test certificate issued before the vehicle is used as an executive private hire vehicle.

3d.58 Shropshire Council reserves the right to require proprietors to rectify any items listed under minor or advisory information on an MOT certificate and to provide evidence that the work has been completed to the Council within a timescale specified by the Council. In the event that a proprietor fails to rectify any items requested by the Council (unless delayed or prevented by sufficient cause accepted and agreed by the Council), the Council may suspend the licence and require the

¹⁷ The requirement to submit an MOT will be in accordance with section 50 of the Local Government (Miscellaneous Provisions) Act 1976

proprietor of that hackney carriage to return all the plates to the Council subject to any appeal period.

Insurance

3d.59 Certificates of insurance are required in accordance with the following requirements:

- The vehicle must have a valid certificate of insurance for private hire including proof of Public Liability insurance for a minimum of £5,000,000, throughout the licence period. Insurance stating covered for public hire will not be accepted for private hire vehicles.
- Certificates of insurance or cover notes issued to cover “any vehicle” or “any driver” must be accompanied by a schedule showing all the vehicles and drivers covered by the insurance as detailed in the certificate of insurance.
- Where a vehicle is insured by a proprietor and the proprietor allows another licensed Shropshire Council driver to drive their vehicle, or any vehicle is insured under a fleet insurance, the proprietor (as the policy holder) is responsible for ensuring that the driver of that vehicle is aware of the content of the policy, including its limitations and exclusions, and that the proprietor keeps records to this effect.
- Where an insurance cover note is provided a full certificate of insurance must be produced to the Council within 7 days of the certificate being received by the owner of the vehicle.
- The proprietor must also obtain information as to any requirement for them to have Employers Liability Indemnity; if there is such a requirement, it must be for a minimum of £1,000,000.

3d.60 With respect to a licensed vehicle, in the event that a proprietor fails to present to the Council a valid certificate of insurance as required (unless delayed or prevented by sufficient cause accepted and agreed by the Council), the Council may suspend the licence and require the proprietor of that private hire vehicle to return all the plates to the Council subject to any appeal period.

V5 registration certificate

3d.61 The Council accepts that a full V5 registration certificate in the new owner’s name is not always available upon first licence or as part of an application to transfer the licensee; however, the green new keepers slip of the V5 form and proof of purchase must be produced. Where possible a full copy of the previous owners V5 registration certificate should be obtained and submitted alongside the green new keepers slip.

3d.62 A full V5 registration certificate and proof of purchase must be produced upon transfer of a vehicle licence. Where possible a full copy of the previous owners V5 registration certificate should be obtained and submitted alongside the V5 green section.

3d.63 Where the green section has been produced on first licensing the vehicle or as part of an application to transfer the licensee, a full V5 registration certificate in the new owner’s name must be produced to the Council within 7 days of the form being received by the owner of the vehicle.

3d.64 Where a licence is issued in advance of a full V5 registration certificate being received and where upon receipt of a full V5 registration certificate information is contained that indicates that a vehicle has, since the date of first registration, been recorded by the DVLA as having sustained structural damage resulting from a road traffic accident, as set out in paragraph 3d.37, the licence will be subject to review at a meeting of the Councils Licensing Panel.

Renewal of a licence

- 3d.65 To allow the vehicle's licence to be renewed, a renewal application form must be received by the Council at least 10 working days prior to the expiry date of the original licence (unless there is satisfactory evidence of exceptional circumstances that are accepted by the Council) to allow the Council sufficient time to process the renewal application. It is the Council's intention to process all valid renewal applications within 10 working days; hence, where applicants fail to submit their renewal application within this timescale, the risk that their licence will expire increases. Once a licence expires, is revoked (subject to a statutory appeal process) or surrendered, it ceases to exist and applicants would not be permitted to drive the private hire vehicle in these circumstances.
- 3d.66 Once a licence ceases to exist a renewal application will not be accepted by the Council (unless there is satisfactory evidence of exceptional circumstances that are accepted by the Council) and the applicant must submit a new vehicle licence application which will be processed in accordance with the Council's new application process.

Renewal application process

- 3d.67 The application form must be fully completed and include all relevant information, supporting documentation and appropriate fee.
- 3d.68 The full fee for the licence is payable at the time the application is submitted. (This includes any application to transfer a vehicle licence onto another vehicle)
- 3d.69 If any part of the application form is incomplete or the relevant information or supporting documentation is not provided, the applicant will be requested to provide the missing information/documentation and informed that the application will not be processed until such time as all the information/documentation is provided. If the applicant fails to provide all the information to complete the application, the application will be rejected.
- 3d.70 Once an application has been accepted by the Licensing Team as a valid application the application process must be completed within 6 months unless prevented from doing so by matters that are outside the applicant's control. When an application is not completed within this timescale the application will be referred to the Licensing Panel for determination where an officer with delegated authority will consider each case on its own individual merits and will determine what action is appropriate and proportionate to the circumstances of the case.
- 3d.71 Any person wishing to renew a licence for an executive private hire vehicle must:
- Submit a completed application form
 - Pay the appropriate licence fee
 - Provide copies of the relevant private hire operator records to evidence the nature of the work carried out over the previous licence period. Operator records must also detail evidence of business to business contracts with clients which require vehicles supplied to be executive in nature
 - Provide a basic criminal record disclosure from the Disclosure and Barring Service, unless the applicant is the holder of a hackney carriage and private hire drivers licence or private hire operators licence issued by Shropshire Council (applicants can apply to <https://www.gov.uk/request-copy-criminal-record>). A basic criminal record disclosure will only be accepted by the Council within 12 months of the date of issue from the Disclosure and Barring Service

- Provide a valid MOT (in accordance with the requirements set out at paragraph 3d.76 below)
- Provide a valid certificate of insurance for private hire including proof of Public Liability insurance for a minimum of £5,000,000, insurance stating covered for public hire will not be accepted for private hire vehicles (in accordance with the requirements set out at paragraph 3d.82 below)
- Where the vehicle is fitted with a mechanically operated ramp, provide a valid certificate/report confirming the ramp complies with the requirements of the Lifting Operations and Lifting Regulations 1998 (NB The proprietor is responsible for ensuring that a competent person carries out the necessary checks in accordance with these Regulations.)
- Where non-mechanical ramps are used, provide confirmation from the proprietor of the vehicle that the ramps comply with the relevant provisions of the Provision and Use of Work Equipment Regulations 1998. (NB Licensing officers will check that the provision of non-mechanical ramps is being maintained by the vehicle proprietor.)
- Where fittings are used to secure wheelchairs to the floor of a vehicle, provide a certificate/report confirming that all the fittings are intact and are free from damage and wear

3d.72 Once an application has been validated and accepted, the Council will:

- Complete an online check of the MOT history for the vehicle
- Where applicable, make enquiries through the Councils adults and childrens social care teams, West Mercia Police (or other relevant force), other local authorities and any other organisation, agency or person that the Council has deemed appropriate to seek information from

3d.73 **NB** For partnerships or companies, the requirements set out in paragraphs 3d.9 to 3d.24 apply to all partners and directors/company secretaries.

3d.74 Where an application is received to change the proprietor of an executive private hire vehicle licence (transfer of licensee), the new proprietor must fulfil the requirements as set out in paragraphs 3d.9 to 3d.24 above.

3d.75 Providing the above are satisfied, Officers will grant the licence. In all other cases, the application will be referred to the Licensing Panel for determination. Each application will be decided on its merits. However, there is a presumption that unless an applicant can demonstrate exceptional circumstances the application will be refused. Whilst it is neither possible nor prudent to draw up a list of what might amount to exceptional circumstances, an applicant who claims that exceptional circumstances exist will be expected to be able to satisfy the Council that it would not frustrate the purposes of this Policy or compromise public safety if the licence were granted. The applicant will be notified in writing if their application is to be determined at a meeting of the Licensing Panel.

MOT requirements¹⁸

3d.76 MOTs are required in accordance with the following requirements:

¹⁸ The requirement to submit an MOT will be in accordance with section 50 of the Local Government (Miscellaneous Provisions) Act 1976

- Vehicles, up to 9 years from date of first registration, must be submitted for an MOT inspection at 6-monthly intervals (and any other inspection deemed necessary by an authorised officer) and the applicant must produce valid MOT certificates to the Council in this respect.
- Once a vehicle reaches the age of 9 years, in addition to the MOT certificate submitted with an application, it must have two other MOT tests per year; tests being spaced evenly throughout the year at four monthly intervals and the applicant must produce valid MOT certificates to the Council in this respect.
- MOT certificates will only be accepted by the Council within 10 working days of the date of issue from the MOT testing centre.
- MOTs must be undertaken by a 'Nominated Tester' or Authorised Vehicle Examiner at a Vehicle Testing Station appointed under Section 45 of The Road Traffic Act 1988; the cost of all tests must be met by the vehicle proprietor.
- The vehicle must have a valid MOT throughout the licence period.

3d.77 The Council will check the MOT history of a licensed vehicle to ensure that the vehicle has not been used to fulfil any executive private hire work on a failed MOT where the vehicle has failed for dangerous (do not drive until repaired) defects or category major (repair immediately) defects.

3d.78 With respect to a licensed vehicle, in the event that a proprietor fails to present to the Council an MOT test certificate as required (unless delayed or prevented by sufficient cause accepted and agreed by the Council), the Council may suspend the licence and require the proprietor of that private hire vehicle to return all the plates to the Council subject to any appeal period.

MOT failures and advisories

3d.79 The Councils position in regards to MOT failures and advisories is as follows:

- Where a vehicle fails an MOT under the category dangerous (do not drive until repaired) defects, DVSA guidance states that this will have a direct and immediate risk which will put passengers and other road users at risk or have a serious impact on the environment. The Council requires all repairs to be undertaken and a new MOT test certificate issued before the vehicle is used as an executive private hire vehicle.
- Where a vehicle fails an MOT under the category major (repair immediately) defects, the Council has a concern for the vehicle safety which may put passengers and other road users at risk or have an impact on the environment. The Council requires all repairs to be undertaken and a new MOT test certificate issued before the vehicle is used as an executive private hire vehicle.

3d.80 Where a proprietor permits a vehicle that has failed an MOT for dangerous (do not drive until repaired) defects, or major (repair immediately) defects, to be used as an executive private hire vehicle, the licence will be referred to the Licensing Panel for review where an officer with delegated authority will consider each case on its own individual merits and will determine what action is appropriate and proportionate to the circumstances of the case.

3d.81 Shropshire Council reserves the right to require proprietors to rectify any items listed under minor or advisory information on an MOT certificate and to provide evidence that the work has been completed to the Council within a timescale specified by the Council. In the event that a proprietor fails to rectify any items requested by the Council (unless delayed or prevented by sufficient cause accepted and agreed by the Council), the Council may suspend the licence and require the

proprietor of that hackney carriage to return all the plates to the Council subject to any appeal period.

Insurance

3d.82 Certificates of insurance are required in accordance with the following requirements:

- The vehicle must have a valid certificate of insurance for private hire including proof of Public Liability insurance for a minimum of £5,000,000, throughout the licence period. Insurance stating covered for public hire will not be accepted for private hire vehicles.
- Certificates of insurance or cover notes issued to cover “any vehicle” or “any driver” must be accompanied by a schedule showing all the vehicles and drivers covered by the insurance as detailed in the certificate of insurance.
- Where a vehicle is insured by a proprietor and the proprietor allows another licensed Shropshire Council driver to drive their vehicle, or any vehicle is insured under a fleet insurance, the proprietor (as the policy holder) is responsible for ensuring that the driver of that vehicle is aware of the content of the policy, including its limitations and exclusions, and that the proprietor keeps records to this effect.
- Where an insurance cover note is provided a full certificate of insurance must be produced to the Council within 7 days of the certificate being received by the owner of the vehicle.
- The proprietor must also obtain information as to any requirement for them to have Employers Liability Indemnity; if there is such a requirement, it must be for a minimum of £1,000,000.

3d.83 With respect to a licensed vehicle, in the event that a proprietor fails to present to the Council a valid certificate of insurance as required (unless delayed or prevented by sufficient cause accepted and agreed by the Council), the Council may suspend the licence and require the proprietor of that private hire vehicle to return all the plates to the Council subject to any appeal period.

Vehicle compliance process

3d.84 Once an application has been validated and accepted a member of the Licensing Team will contact the applicant to arrange a vehicle compliance appointment. At the appointment a vehicle will be subject to a compliance check to ensure:

- That where the vehicle is sufficiently equipped for the provision of one reference wheelchair that the driver presenting the vehicle is capable of safely loading and securing the wheelchair into the vehicle (the vehicle, including seating, wheelchair restraint and ramp, will be photographed and the images held on the vehicle record file for future reference)
- The vehicle has a full size spare wheel or space saver design wheel and the tools to change a wheel OR a contract with a mobile tyre replacement specialist
- At least one no smoking sign is on display in the vehicle
- That where a vehicle is wheelchair accessible a sign confirming the wheelchair accessibility is clearly displayed
- The drivers internal ‘Vehicle Copy’ of drivers badge is displayed ensuring that the licence details and photo are visible to passengers
- Where CCTV is fitted, a CCTV operating in this vehicle sign is on display in the vehicle

3d.85 Vehicle proprietors are required to return the existing licence plate (renewal/transfer vehicles only) at the compliance appointment. Where officers are satisfied that the vehicle meets the

compliance checks, the new licence plates will be issued. If, however, the vehicle does not meet the compliance check, advice will be provided and a further appointment arranged.

Transfer of a licence (Change of vehicle)

- 3d.86 All requests to transfer a vehicle licence (change of vehicle) onto another vehicle will be treated as a new vehicle application (in accordance with the requirements set out at paragraphs 3d.45 to 3d.51).
- 3d.87 Where a proprietor has notified the Council that damage has occurred to a licensed vehicle, resulting in the transfer of licence to a temporary insurance replacement vehicle, proprietors will be required to provide evidence to demonstrate the damage which has occurred to the vehicle, i.e. insurance assessors report.
- 3d.88 Where a wheelchair accessible vehicle has sustained sustained structural damage from a road traffic accident resulting in a DVLA classification under Category S – Structural damage (vehicle that has sustained damage after 1 October 2017) or Category C (vehicle has sustained damage, rendering it beyond economical repair, prior to 1 October 2017), any documents provided to meet the safety requirements of the policy as part of the previous application process (i.e. VCA certificate, IAC or IVA 6) may be invalid. In these circumstances the Council will require the proprietor to submit the vehicle for a new basic voluntary IVA check and provide a valid IVA 6 certificate to the Licensing Team before the licence can be transferred back to the original vehicle.
- 3d.89 Where a wheelchair accessible vehicle has sustained damage that does not affect the validity of the documents provided to meet the safety requirements of the policy as part of the previous application process (i.e. VCA certificate, IAC or IVA 6), provided any repairs have been made by a garage approved and authorised by the insurance company, the Council will require the proprietor to submit confirmation from the insurance company that the repairs have been completed in accordance with the insurance assessors report and a new MOT certificate (in accordance with the requirements set out at paragraph 3d.76 above) to the Licensing Team before the licence can be transferred back to the original vehicle.

Vehicle not fit for the conveyance of passengers

- 3d.90 Where a proprietor has notified the Council that damage has occurred to a vehicle, otherwise than in accordance with relevant road traffic legislation, the Council may require photographic evidence of the damage or for the vehicle to be presented for inspection by an authorised officer of the Council.
- 3d.91 If the authorised officer determines that a vehicle is not fit for the purpose of conveying passengers an authorised officer of the Council may at that time suspend the licence and require the proprietor of the vehicle to return all the vehicles plates to the Council. The suspension will be lifted and the plate returned at such time when the condition of the vehicle is demonstrated, to the satisfaction of the Council, to be fit for conveying passengers.
- 3d.92 The officer may require the proprietor to arrange for a further MOT test, or in respect of wheelchair accessible vehicles a basic voluntary IVA test, to be undertaken and certificate produced before the vehicle will be permitted to operate; this is at the discretion of the authorised officer.

Use of information on and in relation to executive private hire vehicles

- 3d.93 Proprietors must not display advertisements, information, images or other material on executive private hire vehicles.

Closed circuit television (CCTV)

- 3d.94 Proprietors of private hire vehicles are encouraged to install closed circuit television (CCTV) systems providing such systems are installed in accordance with the appropriate legal framework and the Council has been notified, in writing, of their intention to do so.
- 3d.95 Proprietors of executive private hire vehicles must register with the Information Commissioners Office (ICO) and maintain a valid registration throughout the duration of the licence or until such a time as the CCTV has been removed from the licensed vehicle.

Trailers

- 3d.96 Executive private hire vehicles licensed by the Council are permitted to tow trailers only when it is a requirement of the business to business contract and providing that the conditions set out at **Appendix M** are complied with at all times.

Parking/waiting

- 3d.97 Where a driver is illegally parked or creating an obstruction, i.e., in contravention of road traffic legislation and traffic regulation orders (this does not include a legitimate period of time where an executive private hire vehicle has stopped to drop off or pick up a client), the driver's licence may be reviewed and such conduct may be deemed a reasonable cause to revoke or suspend the licence or to take any other appropriate action.

LPG converted vehicles

- 3d.98 The Council must be satisfied that any vehicle that has been converted to LPG has been converted correctly prior to a licence being issued. To this end, the Council will undertake checks with the UK LPG Vehicle Register.
- 3d.99 With respect to new applications, where it is established that a conversion has not been undertaken correctly and/or the vehicle is unsafe in any way, the Council will refuse the application.
- 3d.100 In the event that an LPG conversion has been undertaken on a vehicle during a current licensed period and the proprietor of the vehicle fails to notify the Council within 7 days of the conversion, an authorised officer of the Council will suspend the vehicle licence until such time evidence is available on the UK LPG Vehicle Register.
- 3d.101 In the case of a conversion that has been undertaken on a vehicle during a current licensed period and it is subsequently established that the conversion has not been undertaken correctly and/or the vehicle is unsafe in any way, an authorised officer of the Council will suspend the licence until such time as the conversion has been undertaken correctly and/or it is demonstrated to the satisfaction of the Council that the vehicle is safe.

Production of records/documents

3d.102 Any records required to be retained in accordance with the licence and licence conditions must be produced, on request, to any authorised officer of the Council or to any police officer.

Licence conditions

3d.103 The applicable conditions relevant to an executive private hire vehicle licence are set out at **Appendix E**; these conditions must be complied with. These conditions are in addition to any matters set out within the main body of the Policy.

Main legal requirements

3d.104 Paragraphs 3d.105 to 3d.124 is not exhaustive and unless otherwise specified please refer to the Local Government (Miscellaneous Provisions) Act 1976 for a full list of legal requirements, offences and the maximum penalty upon conviction.

3d.105 Change of proprietor

The proprietor must give notice to the Council of any transfer in his interest in the executive private hire vehicle to a person other than the proprietor whose name is specified in the licence. Such notice must be given, in writing, within 14 days specifying the name and address of the person to whom the vehicle has been transferred.

3d.106 Inspection

The proprietor must present their executive private hire vehicle for inspection and testing by the Council as required, up to a maximum of 3 times during any one period of 12 months.

3d.107 The proprietor must provide, on request, the address where the executive private hire vehicle is kept and allow the Council to inspect and test the vehicle at that address.

3d.108 Accidents

The proprietor, notwithstanding their responsibilities under relevant road traffic legislation, must also report to the Council any accident as soon as reasonably practicable. However, where the vehicle has suffered accident damage that materially affects the safety, performance or appearance of the vehicle, or the comfort or convenience of their clients, the driver must notify the Council within 72 hours.

3d.109 Production of documents

The proprietor must, on request by an authorised officer of the Council or a police officer, produce to the officer for inspection the executive private hire vehicle licence and insurance certificate within 7 days.

3d.110 Return of identification plates

Where a licence is revoked, suspended or expires, the proprietor, when required by the Council to do so must return all the identification plates within 7 days.

3d.111 Transporting children

As a minimum, private hire vehicles must be capable of complying with the requirements set out in the table below, for further guidance see <https://www.gov.uk/child-car-seats-the-rules/when-a-child-can-travel-without-a-car-seat>.

	Front seat	Rear seat	Who is responsible?
Child up to 3 years	Correct child restraints must be used	Correct child restraint must be used. If a restraint is not available in a licensed hackney carriage or private hire vehicle, the child may travel unrestrained.	Driver**
Child from 3rd birthday to 12th birthday or 135 cm in height whichever they reach first	Correct child restraints must be used	Where seat belts are fitted, the correct child restraint must be used. The child must use adult belt if the correct child restraint is not available as follows: in a licensed hackney carriage or private hire vehicle; or for a short distance in an unexpected necessity; or two occupied child restraints prevent fitting of a third. A child 3 years and over may travel unrestrained in the rear seat of a vehicle if seat belts are not fitted in the rear.	Driver**
Child over 135 cm in height or 12 or 13 years old	Seat belt must be worn if available*	Seat belt must be worn if available.	Driver**
Passengers aged 14 years and over	Seat belt must be worn if available*	Seat belt must be worn if available.	Passenger

*Vehicles built before 1965 are not required to have fitted seatbelts.

**Drivers must inform parents/carers that the decision to permit children to travel in the vehicle, without the correctly sized seat restraints (as permitted by relevant legislation) and with the obvious risks associated with such an action, remains with the parent/carer responsible for the children and not with the driver of the vehicle.

3d.112 Ranks/stands

An executive private hire vehicle must not wait (stop or park) on any rank/stand.

3e. NOVELTY PRIVATE HIRE VEHICLES INCLUDING LIMOUSINES AND VINTAGE VEHICLES

Summary

- 3e.1 Novelty private hire vehicles are licensed in accordance with the provisions of the Local Government (Miscellaneous Provisions) Act 1976. Section 75(3) provides for the Council to issue an exemption notice. The Council will only consider an exemption where the applicant can demonstrate that the requirements of this section are fully satisfied. Novelty private hire vehicles must not have the appearance of a hackney carriage vehicle.
- 3e.2 When considering whether a vehicle is a novelty private hire vehicle by the nature of the work it does, Shropshire Council shall have regard to the document Private Hire Vehicle Licensing - A note for guidance from the Department for Transport (August 2011).
- 3e.3 The Council legally cannot limit the number of novelty private hire vehicle licences that it will issue.
- 3e.4 The Council will not licence a vehicle for hire and reward which is licensed by another local authority or allow or permit a private hire vehicle identification plate issued by another authority to be displayed on the vehicle.

Business model for novelty private hire vehicles

- 3e.5 Novelty private hire vehicles must only be used for special events, which are defined as the provision of a vehicle or vehicles for events such as but not limited to, weddings, proms, anniversaries, birthdays, stag and hen parties and **not** for 'normal' or general purpose private hire use.
- 3e.6 Bookings taken in respect of clients who require a novelty private hire must require a deposit to be paid for in advance.
- 3e.7 Applicants must be able to demonstrate the vehicle will only be used fulfil the provision of novelty private hire vehicle bookings at special events by:
- Providing written confirmation from their private hire operator that the vehicle will only undertake novelty private hire vehicle work for special events
 - Providing written confirmation that the vehicle will be used solely for novelty private hire vehicle work and not for 'normal' or general private hire use

Applicant

- 3e.8 The applicant for a vehicle licence must be the person who is the legal owner of the vehicle concerned and entitled to have ownership of the vehicle¹⁹.

Fit and proper person

- 3e.9 The proprietor of a licensed novelty private hire vehicle provides a public service that impacts on public safety. On this basis, the Council will not licence a vehicle as a novelty private hire vehicle

¹⁹ There is no legal definition of proprietor within relevant legislation, however, the Council has taken the view that proprietor means the legal owner based on common usage of the term.

unless it is satisfied that the proprietor of the vehicle meets all the criteria to be deemed a fit and proper person as set in **Appendix I**.

Proprietors who apply for a novelty private hire vehicle licence and who hold a valid Shropshire Council hackney carriage/private hire drivers licence or a valid Shropshire Council private hire operator licence

- 3e.10 The Council adopts the same principles when determining whether an applicant is a fit and proper person to hold a vehicle licence as it does to persons applying for a drivers licence. In this respect, applicants are required to have due regard, as appropriate, to the requirements and information set out at paragraphs 3a.4 to 3a.24 of the Policy.

Proprietors who apply for a novelty private hire vehicle licence and who do not hold a valid Shropshire Council hackney carriage/private hire drivers licence or a valid Shropshire Council private hire operator licence

- 3e.11 In considering the fit and proper person test, all applicants on initial application must provide a basic criminal record disclosure from the Disclosure and Barring Service. All applicants on renewal must provide a basic criminal record disclosure that has been issued by the Disclosure and Barring Service within the previous 12 months of the date that the application is received by the Council. On new or renewal applications the Council will also make additional enquiries through its adults and childrens social care teams, directly with West Mercia Police (and other relevant police forces, where appropriate), other relevant local authorities (particularly Telford & Wrekin Council and City of Wolverhampton Council) and any other appropriate organisation, agency or person in order to ensure the Council is in a position to make as accurate an assessment of the applicant's fitness to hold a licence as is reasonably practicable.
- 3e.12 With specific reference to existing licence holders, where there is any cause for a licence to be reviewed, the Council will make additional enquiries through its adults and childrens social care teams, directly with West Mercia Police (and other relevant police forces, where appropriate), other relevant local authorities (particularly Telford & Wrekin Council and City of Wolverhampton Council) and any other appropriate organisation, agency or person in order to ensure the Council is in a position to make as accurate an assessment of the licence holders fitness to hold a licence as is reasonably practicable. Depending on the circumstances of the case, the Council may request the licence holder to consent to a further basic criminal record disclosure, the cost of which lies with the licence holder. Where a licence holder refuses to consent to a further check the Council will take this into consideration in determining their continuing fitness to hold a licence.
- 3e.13 When assessing the fitness of an applicant to hold a novelty private hire vehicle proprietors licence, the Council will consider the applicant's criminal history as a whole, together with all other relevant evidence, information and intelligence including their history (e.g. complaints and positive comments from the public, compliance with licence conditions and willingness to co-operate with licensing officers) whilst holding a licence from the Council or any other authority. Particular attention will be given to patterns of behaviour, irrespective of the time-scale over which they have occurred, both in terms of proven criminal offences and other behaviour/conduct that may indicate the safety and welfare of the public may be at risk from the applicant.
- 3e.14 In addition, an important element associated with the fitness to hold a licence is the appearance and behaviour of an applicant. Consequently, the Council requires all applicants to maintain a reasonable standard of appearance and behaviour when in contact and dealing with all persons, including but not limited to, other road users, pedestrians, customers, the general public, other

licensed operators and drivers of hackney carriage and private hire vehicles, Council officers and elected members at all times. Applicants must also co-operate with any reasonable request made by an authorised officer of the Council or any police officer.

- 3e.15 It must also be recognised that the Council will consider all relevant criminal history, behaviour and conduct irrespective of whether the specific history, behaviour or conduct occurred whilst applicants were directly engaged in hackney carriage or private hire licensed work at the time or whether they occurred during the applicants' own personal time. The Council considers a person or individual who has a propensity to commit offences and/or demonstrate unacceptable conduct whilst not engaged in hackney carriage or private hire work to be equally as serious as offences and/or unacceptable conduct committed whilst engaged in hackney carriage or private hire work.

Criminal record disclosure

- 3e.16 All unspent convictions, including cautions, will be taken into account when considering a person's suitability to hold a licence. Consequently, applicants are required to provide details of all unspent convictions and cautions, including driving endorsements (driving convictions) and disqualification periods relating to traffic offences.
- 3e.17 Although cautions are generally not as serious as convictions, ordinarily as a result of the circumstances under which they are offered, they do require an admission of guilt before they can be issued which is equivalent to a guilty plea on prosecution. Consequently, a caution is regarded in exactly the same way as a conviction. Fixed penalties, community resolutions or similar sanctions will also be considered in the same way as a conviction on the basis that payment of a fixed penalty indicated an acceptance of guilt and a community resolution can only be imposed following an admission of guilt. As a result, each of these sanctions is a valuable indication as to an applicant's character and whether they are a fit and proper person to hold or be granted a licence.
- 3e.18 A criminal record does not automatically bar an applicant from holding a licence; however, it will be a significant factor when determining whether a licence ought to be granted or not. Where an applicant has previous criminal convictions, these will be considered in line with the guidance set out in **Appendix I**. However, the over-riding consideration will always be to ensure the safety and welfare of the public.
- 3e.19 Persons who have not been resident within the United Kingdom for the five years prior to submitting an application, will be required to produce a certificate of good conduct or equivalent document (at their own cost) issued by the relevant Embassy or High Commission. The certificate must be authenticated, translated and sealed by the Embassy or High Commission. In the event that an applicant is not able to obtain a certificate of good conduct, they may submit a statutory declaration with regard to their conduct, which must be completed in the presence of a practising solicitor. The Council may contact the relevant Embassy, High Commission, solicitor or other appropriate body to verify any documents provided. Contact details for Embassies and High Commissions can be found from the Foreign, Commonwealth & Development Office (FCDO) on the GOV.UK website at <https://www.gov.uk/government/world>. The FCDO may be contacted for further assistance by telephone on 020 7008 5000, by email at fcdo.correspondence@fcdo.gov.uk or by post at the FCDO, King Charles Street, London, SW1A 2AH.
- 3e.20 Applicants who have spent three continuous months or more living outside the United Kingdom, during the period of their licence, will be required to produce a certificate of good conduct or equivalent document (at their own cost). This certificate must be issued by the relevant Embassy

or High Commission for the country or countries lived in during this period and meet the requirements as set out at 3e.19 above. It is recognised that some countries will not provide a certificate of good conduct unless the individual has been resident for six months or more. Where a relevant Embassy or High Commission refuse to issue a certificate of good conduct, applicants must provide written confirmation from the Embassy of any refusal to the Licensing Team.

Non-conviction information

- 3e.21 In addition to conviction/caution information, applicants are expected to provide details, within 48 hours of all warnings, driving endorsements (driving convictions)/disqualification periods relating to traffic offences, fixed penalties, community resolutions and any other similar sanctions, together with any charges or arrests that they are the subject of in connection with criminal offences, whether or not actually charged with the offence, and details of any allegations of involvement in criminal activity or where they have been questioned in connection with any alleged criminal activity or inappropriate/unacceptable behaviour or any other relevant pending matter.
- 3e.22 Where an applicant is the subject of an outstanding charge or summons, their application may continue to be processed; however, depending on the circumstances, it is unlikely that a decision on the application will be made until the conclusion of the criminal proceedings. Where the outstanding charge or summons involves a serious offence and/or the individual's offending history and behaviour/conduct indicates a pattern of unlawful or unacceptable behaviour/character traits, then the application is likely to be refused.
- 3e.23 Where there is evidence/information that an applicant has been arrested or charged but not convicted of offences and the nature of this evidence/information suggests the applicant may not be a fit and proper person, the Council will give serious consideration to refusing an application or revoking an existing licence.

Period of licence

- 3e.24 Vehicle licences will be issued for a maximum period of 12 months.

Vehicle licence plates

- 3e.25 The external rear plate and the internal plate, identifying the vehicle as a novelty private hire vehicle, show the licence details on a yellow background with the Shropshire Council logo.

Vehicle specification

- 3e.26 The Council requires novelty private hire vehicles to comply with the following requirements:
- 3e.27 For the purpose of licensing a limousine is described as a luxurious vehicle that has been stretched by the insertion of an additional section not exceeding 3048 millimetres to extend the length of the vehicle. The vehicle shall be capable of carrying up to but not exceeding eight passengers. Applicants are directed towards the VOSA 'Guidance for Operators of Stretch Limousines' (March 2011)²⁰.

²⁰ <https://www.gov.uk/government/publications/guidance-for-operators-of-stretch-limousines>

- 3e.28 Limousines will be licensed by the Council; however, the over-riding consideration will be the safety of the vehicle. Such types of vehicle will only be licensed as novelty private hire vehicles. They will be subject to the production of specific documents, in original form or as copies certified by the vehicle builder (uncertified photocopies will not be accepted), and to conditions as set out below. These are in addition to the documents required and the conditions applicable to novelty private hire vehicle licensing.
- 3e.29 The following documentation must be produced prior to licensing:
- Evidence of compliance through the Single Vehicle Approval Scheme (SVA) or Individual Vehicle Approval Scheme (IVA)
 - Public Liability Insurance documentation for a minimum of £5,000,000
 - Documentation recording the overall weight of the vehicle (as displayed on the vehicle.)
- 3e.30 The following additional conditions apply:
- The tyres must be of an appropriate weight loading for the limousine, novelty vehicles and vintage vehicles.
 - The sale of alcohol in the vehicle must be covered by a separate licence in accordance with the Licensing Act 2003.
- 3e.31 In addition to stretched limousines, novelty vehicles, e.g. fire engines, and vintage vehicles will also be considered for licensing. Such vehicles do not have to comply with the New Car Assessment Programme (NCAP) rating or the requirements set out in paragraphs 3c.28 to 3c.30 of the Standard Private Hire Vehicle section.
- 3e.32 Applicants considering applying for a novelty private hire vehicle are strongly advised to contact the licensing team in advance of purchasing any vehicle to ensure it is appropriate to be licensed.

Safety

- 3e.33 The Council will not licence any new vehicle that since the date of first registration has been recorded by the DVLA as having sustained structural damage resulting from a road traffic accident (an insurance 'Write Off' under the DVLA's Category S – Structural damage classification for vehicle that has sustained damage after 1 October 2017 or Category C where a vehicle has sustained damage, rendering it beyond economical repair, prior to 1 October 2017). This information can be found in the Special Notes section of the V5 registration Certificate.
- 3e.34 Where a proprietor has notified the Council that a licensed vehicle has sustained structural damage from a road traffic accident resulting in a DVLA classification under Category S – Structural damage (vehicle that has sustained damage after 1 October 2017) or Category C (vehicle has sustained damage, rendering it beyond economical repair, prior to 1 October 2017), any documents provided to meet the safety requirements of the policy as part of the previous application process (i.e. SVA certificate or IVA certificate) will be invalid. The proprietor will be required to submit the vehicle for a new voluntary IVA check and provide a valid IVA certificate to the Licensing Team.

List of Designated Wheelchair Accessible Vehicles

- 3e.35 Section 167 of the Equality Act 2010 requires all local authorities to maintain a list of designated wheelchair accessible vehicles.

- 3e.36 All wheelchair accessible vehicles must be capable of transporting the user of a “reference wheelchair” and will be included within the Council’s list of designated vehicles. Specifications for a “reference wheelchair” can be found at **Appendix J**.
- 3e.37 Section 172 of the Equality Act 2010 provides for an appeal to be made against the decision to include a vehicle on the list of designated wheelchair accessible vehicles. Any appeal must be made to the Magistrates Court within 28 days of the vehicle being included on the list.
- 3e.38 Proprietors have a responsibility to ensure that any Shropshire Council licensed driver who drives one of their wheelchair accessible vehicles is made aware of their duties in respect of carrying disabled persons in wheelchairs when driving a designated wheelchair accessible vehicle.
- 3e.39 Failure to comply with the duties listed under section 165 of the Equality Act 2010 is a criminal offence.

Drivers of novelty private hire vehicles including limousines and vintage private hire vehicles

- 3e.40 Proprietors are required to ensure that the driver of a novelty private hire vehicle has the correct DVLA driving licence for the size of vehicle that they will be driving.
- 3e.41 Proprietors are required to ensure that the driver of a small limousine holds a full DVLA (category B) driving licence, providing the vehicle does not exceed 3.5 tonnes.

Other Requirements

- 3e.42 Vehicles must not seat more than eight passengers (not including the driver) and:
- (a) Be a Light Passenger Vehicle as defined by section 85 of the Road Traffic Act 1988 and have a minimum of 4 wheels
 - (b) Provide sufficient means by which any person in the carriage may communicate with the driver
 - (c) Vehicle owners and operators are encouraged to use vehicles where the entire external bodywork of the vehicle is NOT black in colour. This does not prohibit the display of advertisements, information, images and other material as authorised by the Council
 - (d) All paintwork must be maintained free from dents, scratches or rust
 - (e) Have a watertight roof or covering
 - (f) Provide at least two windows on each side of the vehicle of which one window on one side must have a means of opening/closing
 - (g) Tinted windows will only be permitted in accordance with the manufacturers or specialist coachbuilder’s specification and must comply with the Road Vehicles (Construction & Use) Regulations 1986 as amended. The Council will not permit any form of additional film to darken or tint the glass on any part of the vehicle
 - (h) Have seats that are properly cushioned and covered
 - (i) Have a floor provided with a proper carpet, mat, or other suitable covering
 - (j) Have fittings (including fittings that are used to secure wheelchairs to the floor of the vehicle) and furniture in a clean condition and be well maintained and in every way fit for public service
 - (k) Provide means for securing luggage if the carriage is so constructed as to carry luggage
 - (l) Where tilting passenger seats are fitted the seat must:

- Be forward facing (with the exception of the fold down seats fitted onto the bulkhead/partition of a purpose-built hackney carriage)
 - Designed for use by an adult
 - Have a three point seatbelt
- (m) Have a minimum of four passenger doors including an entry/exit point for the driver
- (n) Be maintained in a sound mechanical and structural condition at all times
- (o) Have a full size spare wheel or space saver design wheel and the tools to change a wheel OR a contract with a mobile tyre replacement specialist (in any event where a spare wheel has been used, it is only to permit the current fare to be completed and any defective wheel must be replaced before taking another fare to ensure passenger safety); all pneumatic tyres, including the spare, must comply with the vehicle manufacturer's specification and any relevant legislation
- (p) Be maintained in a clean and safe condition at all times from both exterior and interior perspectives
- (q) Proprietors are encouraged to have provision for the legal transportation of a minimum of one "reference wheelchair" at all times. Specifications for a "reference wheelchair" can be found at **Appendix J**
- (r) When transporting a wheelchair user, where a seat has to be removed in order to accommodate a passenger in a wheelchair, proprietors must store the seat securely away from the passengers and driver (e.g. in the boot or other suitable storage facility away from the vehicle)
- (s) Where a mechanical ramp is fitted, comply with requirements of the Lifting Operations and Lifting Equipment Regulations 1998
- (t) Where a non-mechanical ramp is fitted, comply with the relevant provisions of the Provision and Use of Work Equipment Regulations 1998
- (u) When transporting a wheelchair user, where the wheelchair user chooses to transfer to a passenger seat, proprietors must store the wheelchair securely away from the passengers and driver (e.g. in the boot)

New application process

- 3e.43 The application form must be fully completed and include all relevant information, supporting documentation and appropriate fee.
- 3e.44 The full fee for the licence is payable at the time the application is submitted. (This includes any application to transfer a vehicle licence onto another vehicle)
- 3e.45 If any part of the application form is incomplete or the relevant information or supporting documentation is not provided, the applicant will be requested to provide the missing information/documentation and informed that the application will not be processed until such time as all the information/documentation is provided. If the applicant fails to provide all the information to complete the application, the application will be rejected.
- 3e.46 Once an application has been accepted by the Licensing Team as a valid application the application process must be completed within 6 months unless prevented from doing so by matters that are outside the applicant's control. When an application is not completed within this timescale the application will be referred to the Licensing Panel for determination where an officer with delegated authority will consider each case on its own individual merits and will determine what action is appropriate and proportionate to the circumstances of the case.
- 3e.47 Any person wishing to licence a novelty private hire vehicle must

- Submit a completed application form
- Submit a completed reference form, unless the applicant is the holder of a hackney carriage and private hire drivers licence or private hire operator licence issued by Shropshire Council (NB the referees must be from either professional or business sources who have known the applicant for at least two years. In addition, the Council will not accept references from family members, drivers, operators, vehicle proprietors licensed with any local authority or, where relevant, the applicant's future employer unless there is satisfactory evidence of exceptional circumstances that are accepted by the Council). The Council reserves the right to refuse a reference where the Council deems the referee is not acceptable
- Pay the appropriate licence fee
- Provide a basic criminal record disclosure from the Disclosure and Barring Service, unless the applicant is the holder of a hackney carriage and private hire drivers licence or private hire operator licence issued by Shropshire Council (applicants can apply to <https://www.gov.uk/request-copy-criminal-record>). A basic criminal record disclosure will only be accepted by the Council within 12 months of the date of issue from the Disclosure and Barring Service
- Provide evidence of compliance through the Single Vehicle Approval Scheme (SVA) or Individual Vehicle Approval Scheme (IVA)
- Provide documentation recording the overall weight of the vehicle (as displayed on the vehicle)
- Provide a valid MOT (in accordance with the requirements set out at paragraph 3e.54 below)
- Provide a valid certificate of insurance for private hire including proof of public liability insurance for a minimum of £5,000,000, insurance stating covered for public hire will not be accepted for private hire vehicles (in accordance with the requirements set out at paragraph 3e.58 below)
- Provide the full V5 registration certificate (note the alternative interim measures outlined in paragraph 3e.60 to 3e.63)
- Where a meter is fitted, provide a valid certificate/report to confirm the vehicle is fitted with a taximeter in accordance with the requirements set out at paragraph 3e.53 below
- Where the vehicle is fitted with a mechanically operated ramp, provide a valid certificate/report confirming the ramp complies with the requirements of the Lifting Operations and Lifting Equipment Regulations 1998 (NB The proprietor is responsible for ensuring that a competent person carries out the necessary checks in accordance with these Regulations.)
- Where non-mechanical ramps are used, provide confirmation from the proprietor of the vehicle that the ramps comply with the relevant provisions of the Provision and Use of Work Equipment Regulations 1998. (NB Licensing officers will check that the provision of non-mechanical ramps is being maintained by the vehicle proprietor.)
- Where fittings are used to secure wheelchairs to the floor of a vehicle, provide a certificate/report confirming that all the fittings are intact and are free from damage and wear

3e.48 Once an application has been validated and accepted, the Council will:

- Make enquiries through the Councils adults and childrens social care teams, West Mercia Police (or other relevant force), other local authorities and any other organisation, agency or person that the Council has deemed appropriate to seek information from; and
- Where applicable, write to the referees provided

- 3e.49 **NB** For partnerships or companies, the requirements set out in paragraphs 3e.8 to 3e.23 apply to all partners and directors/company secretaries.
- 3e.50 Where an application is received to change the proprietor of a novelty private hire vehicle licence (transfer of licensee), the new proprietor must fulfil the requirements as set out in paragraphs 3e.8 to 3e.23 above.
- 3e.51 Paragraphs 3e.8 to 3e.23 above do not apply to applicants to transfer a vehicle licence onto another vehicle, on a temporary basis, by an accident management company.
- 3e.52 Providing the above are satisfied, Officers will grant the licence. In all other cases, the application will be referred to the Licensing Panel for determination. Each application will be decided on its merits. However, there is a presumption that unless an applicant can demonstrate exceptional circumstances the application will be refused. Whilst it is neither possible nor prudent to draw up a list of what might amount to exceptional circumstances, an applicant who claims that exceptional circumstances exist will be expected to be able to satisfy the Council that it would not frustrate the purposes of this Policy or compromise public safety if the licence were granted. The applicant will be notified in writing if their application is to be determined at a meeting of the Licensing Panel.

Taximeters

- 3e.53 Novelty private hire vehicles will not require a meter. However, if a meter is fitted, it must be:
- Certified by a notified body in accordance with the Measuring Instruments Directive (MID) (2004/22/EC), in particular Annex 007
 - Fitted with a device, the use/action of which will bring the taximeter into action and cause the word 'HIRED' to appear on the face of the taximeter and such a device must be capable of being locked in a position such that the machinery of the taximeter is not in action and that no fare is recorded on the face of the taximeter
 - Calibrated against a measured distance and by reference to the private hire operator's tariff
 - Fixed to the vehicle with appropriate seals/appliances to prevent any person from tampering with the meter except by breaking, damaging, or permanently displacing the seals/appliances
 - Have the word 'FARE' printed on the face of the meter in plain letters so as clearly to apply to the fare recorded thereon
 - Supported by a Shropshire Council certificate/report of compliance (the Council will only accept a certificate that has been issued within the previous 10 working days)

MOT requirements²¹

- 3e.54 MOTs are required in accordance with the following requirements:
- Vehicles, up to 9 years from date of first registration, must be submitted for an MOT inspection at 6-monthly intervals (and any other inspection deemed necessary by an authorised officer) and the applicant must produce valid MOT certificates to the Council in this respect.

²¹ The requirement to submit an MOT will be in accordance with section 50 of the Local Government (Miscellaneous Provisions) Act 1976

- Once a vehicle reaches the age of 9 years, in addition to the MOT certificate submitted with an application, it must have two other MOT tests per year; tests being spaced evenly throughout the year at four monthly intervals and the applicant must produce valid MOT certificates to the Council in this respect.
- MOT certificates will only be accepted by the Council within 10 working days of the date of issue from the MOT testing centre.
- MOTs must be undertaken by a 'Nominated Tester' or Authorised Vehicle Examiner at a Vehicle Testing Station appointed under Section 45 of The Road Traffic Act 1988; the cost of all tests must be met by the vehicle proprietor.
- The vehicle must have a valid MOT throughout the licence period.

3e.55 With respect to a licensed vehicle, in the event of a proprietor failing to present to the Council an MOT test certificate as required (unless delayed or prevented by sufficient cause accepted and agreed by the Council), the Council may suspend the licence and require the proprietor of that hackney carriage to return all the plates to the Council subject to any appeal period.

MOT failures and advisories

3e.56 The Councils position in regards to MOT failures and advisories is as follows:

- Where a vehicle fails an MOT under the category dangerous (do not drive until repaired) defects, DVSA guidance states that this will have a direct and immediate risk which will put passengers and other road users at risk or have a serious impact on the environment. The Council requires all repairs to be undertaken and a new MOT test certificate issued before the vehicle is used as a novelty private hire vehicle.
- Where a vehicle fails an MOT under the category major (repair immediately) defects, the Council has a concern for the vehicle safety which may put passengers and other road users at risk or have an impact on the environment. The Council requires all repairs to be undertaken and a new MOT test certificate issued before the vehicle is used as a novelty private hire vehicle.

3e.57 Shropshire Council reserves the right to require proprietors to rectify any items listed under minor or advisory information on an MOT certificate and to provide evidence that the work has been completed to the Council within a timescale specified by the Council. In the event that a proprietor fails to rectify any items requested by the Council (unless delayed or prevented by sufficient cause accepted and agreed by the Council), the Council may suspend the licence and require the proprietor of that hackney carriage to return all the plates to the Council subject to any appeal period.

Insurance

3e.58 Certificates of insurance are required in accordance with the following requirements:

- The vehicle must have a valid certificate of insurance for private hire including proof of Public Liability insurance for a minimum of £5,000,000, throughout the licence period. Insurance stating covered for public hire will not be accepted for private hire vehicles.
- Certificates of insurance or cover notes issued to cover "any vehicle" or "any driver" must be accompanied by a schedule showing all the vehicles and drivers covered by the insurance as detailed in the certificate of insurance.
- Where a vehicle is insured by a proprietor and the proprietor allows another licensed Shropshire Council driver to drive their vehicle, or any vehicle is insured under a fleet

insurance, the proprietor (as the policy holder) is responsible for ensuring that the driver of that vehicle is aware of the content of the policy, including its limitations and exclusions, and that the proprietor keeps records to this effect.

- Where an insurance cover note is provided a full certificate of insurance must be produced to the Council within 7 days of the certificate being received by the owner of the vehicle.
- The proprietor must also obtain information as to any requirement for them to have Employers Liability Indemnity; if there is such a requirement, it must be for a minimum of £1,000,000.

3e.59 With respect to a licensed vehicle, in the event that a proprietor fails to present to the Council a valid certificate of insurance as required (unless delayed or prevented by sufficient cause accepted and agreed by the Council), the Council may suspend the licence and require the proprietor of that private hire vehicle to return all the plates to the Council subject to any appeal period.

V5 registration certificate

3e.60 The Council accepts that a full V5 registration certificate in the new owner's name is not always available upon first licence or as part of an application to transfer the licensee; however, the green new keepers slip of the V5 form and proof of purchase must be produced. Where possible a full copy of the previous owners V5 registration certificate should be obtained and submitted alongside the green new keepers slip.

3e.61 A full V5 registration certificate and proof of purchase must be produced upon transfer of a vehicle licence. Where possible a full copy of the previous owners V5 registration certificate should be obtained and submitted alongside the V5 green section.

3e.62 Where the green section has been produced on first licensing the vehicle or as part of an application to transfer the licensee, a full V5 registration certificate in the new owner's name must be produced to the Council within 7 days of the form being received by the owner of the vehicle.

3e.63 Where a licence is issued in advance of a full V5 registration certificate being received and where upon receipt of a full V5 registration certificate information is contained that indicates that a vehicle has, since the date of first registration, been recorded by the DVLA as having sustained structural damage resulting from a road traffic accident, as set out in paragraph 3e.33, the licence will be subject to review at a meeting of the Councils Licensing Panel.

Renewal of a licence

3e.64 To allow the vehicle's licence to be renewed, a renewal application form must be received by the Council at least 10 working days prior to the expiry date of the original licence (unless there is satisfactory evidence of exceptional circumstances that are accepted by the Council) to allow the Council sufficient time to process the renewal application. It is the Council's intention to process all valid renewal applications within 10 working days; hence, where applicants fail to submit their renewal application within this timescale, the risk that their licence will expire increases. Once a licence expires, is revoked (subject to a statutory appeal process) or surrendered, it ceases to exist and applicants would not be permitted to drive the private hire vehicle in these circumstances.

3e.65 Once a licence ceases to exist a renewal application will not be accepted by the Council (unless there is satisfactory evidence of exceptional circumstances that are accepted by the Council) and the applicant must submit a new vehicle licence application which will be processed in accordance with the Council's new application process.

Renewal application process

- 3e.66 The application form must be fully completed and include all relevant information, supporting documentation and appropriate fee.
- 3e.67 The full fee for the licence is payable at the time the application is submitted. (This includes any application to transfer a vehicle licence onto another vehicle)
- 3e.68 If any part of the application form is incomplete or the relevant information or supporting documentation is not provided, the applicant will be requested to provide the missing information/documentation and informed that the application will not be processed until such time as all the information/documentation is provided. If the applicant fails to provide all the information to complete the application, the application will be rejected.
- 3e.69 Once an application has been accepted by the Licensing Team as a valid application the application process must be completed within 6 months unless prevented from doing so by matters that are outside the applicant's control. When an application is not completed within this timescale the application will be referred to the Licensing Panel for determination where an officer with delegated authority will consider each case on its own individual merits and will determine what action is appropriate and proportionate to the circumstances of the case.
- 3e.70 Any person wishing to renew a licence for a novelty private hire vehicle must:
- Submit a completed application form
 - Pay the appropriate licence fee
 - Provide a basic criminal record disclosure from the Disclosure and Barring Service, unless the applicant is the holder of a hackney carriage and private hire drivers licence or private hire operators licence issued by Shropshire Council (applicants can apply to <https://www.gov.uk/request-copy-criminal-record>). A basic criminal record disclosure will only be accepted by the Council within 12 months of the date of issue from the Disclosure and Barring Service
 - Provide a valid MOT (in accordance with the requirements set out at paragraph 3e.75 below)
 - Provide a valid certificate of insurance for private hire including proof of Public Liability insurance for a minimum of £5,000,000, insurance stating covered for public hire will not be accepted for private hire vehicles (in accordance with the requirements set out at paragraph 3e.81 below)
 - Where the vehicle is fitted with a mechanically operated ramp, provide a valid certificate/report confirming the ramp complies with the requirements of the Lifting Operations and Lifting Equipment Regulations 1998 (NB The proprietor is responsible for ensuring that a competent person carries out the necessary checks in accordance with these Regulations.)
 - Where non-mechanical ramps are used, provide confirmation from the proprietor of the vehicle that the ramps comply with the relevant provisions of the Provision and Use of Work Equipment Regulations 1998. (NB Licensing officers will check that the provision of non-mechanical ramps is being maintained by the vehicle proprietor.)
 - Where fittings are used to secure wheelchairs to the floor of a vehicle, provide a certificate/report confirming that all the fittings are intact and are free from damage and wear

3e.71 Once an application has been validated and accepted, the Council will:

- Complete an online check of the MOT history for the vehicle
- Where applicable, make enquiries through the Councils adults and childrens social care teams, West Mercia Police (or other relevant force), other local authorities and any other organisation, agency or person that the Council has deemed appropriate to seek information from

3e.72 **NB** For partnerships or companies, the requirements set out in paragraphs 3e.8 to 3e.23 apply to all partners and directors/company secretaries.

3e.73 Where an application is received to change the proprietor of a novelty private hire vehicle licence (transfer of licensee), the new proprietor must fulfil the requirements as set out in paragraphs 3e.8 to 3e.23 above.

3e.74 Providing the above are satisfied, Officers will grant the licence. In all other cases, the application will be referred to the Licensing Panel for determination. Each application will be decided on its merits. However, there is a presumption that unless an applicant can demonstrate exceptional circumstances the application will be refused. Whilst it is neither possible nor prudent to draw up a list of what might amount to exceptional circumstances, an applicant who claims that exceptional circumstances exist will be expected to be able to satisfy the Council that it would not frustrate the purposes of this Policy or compromise public safety if the licence were granted. The applicant will be notified in writing if their application is to be determined at a meeting of the Licensing Panel.

MOT requirements²²

3e.75 MOTs are required in accordance with the following requirements:

- Vehicles, up to 9 years from date of first registration, must be submitted for an MOT inspection at 6-monthly intervals (and any other inspection deemed necessary by an authorised officer) and the applicant must produce valid MOT certificates to the Council in this respect.
- Once a vehicle reaches the age of 9 years, in addition to the MOT certificate submitted with an application, it must have two other MOT tests per year; tests being spaced evenly throughout the year at four monthly intervals and the applicant must produce valid MOT certificates to the Council in this respect.
- MOT certificates will only be accepted by the Council within 10 working days of the date of issue from the MOT testing centre.
- MOTs must be undertaken by a 'Nominated Tester' or Authorised Vehicle Examiner at a Vehicle Testing Station appointed under Section 45 of The Road Traffic Act 1988; the cost of all tests must be met by the vehicle proprietor.
- The vehicle must have a valid MOT throughout the licence period.

3e.76 The Council will check the MOT history of a licensed vehicle to ensure that the vehicle has not been used to fulfil any novelty private hire work on a failed MOT where the vehicle has failed for dangerous (do not drive until repaired) defects or category major (repair immediately) defects.

²² The requirement to submit an MOT will be in accordance with section 50 of the Local Government (Miscellaneous Provisions) Act 1976

3e.77 With respect to a licensed vehicle, in the event that a proprietor fails to present to the Council an MOT test certificate as required (unless delayed or prevented by sufficient cause accepted and agreed by the Council), the Council may suspend the licence and require the proprietor of that novelty private hire vehicle to return all the plates to the Council subject to any appeal period.

MOT failures and advisories

3e.78 The Council's position in regards to MOT failures and advisories is as follows:

- Where a vehicle fails an MOT under the category dangerous (do not drive until repaired) defects, DVSA guidance states that this will have a direct and immediate risk which will put passengers and other road users at risk or have a serious impact on the environment. The Council requires all repairs to be undertaken and a new MOT test certificate issued before the vehicle is used as a novelty private hire vehicle.
- Where a vehicle fails an MOT under the category major (repair immediately) defects, the Council has a concern for the vehicle safety which may put passengers and other road users at risk or have an impact on the environment. The Council requires all repairs to be undertaken and a new MOT test certificate issued before the vehicle is used as a novelty private hire vehicle.

3e.79 Where a proprietor permits a vehicle that has failed an MOT for dangerous (do not drive until repaired) defects, or major (repair immediately) defects, to be used as a novelty private hire vehicle, the licence will be referred to the Licensing Panel for review where an officer with delegated authority will consider each case on its own individual merits and will determine what action is appropriate and proportionate to the circumstances of the case.

3e.80 Shropshire Council reserves the right to require proprietors to rectify any items listed under minor or advisory information on an MOT certificate and to provide evidence that the work has been completed to the Council within a timescale specified by the Council. In the event that a proprietor fails to rectify any items requested by the Council (unless delayed or prevented by sufficient cause accepted and agreed by the Council), the Council may suspend the licence and require the proprietor of that hackney carriage to return all the plates to the Council subject to any appeal period.

Insurance

3e.81 Certificates of insurance are required in accordance with the following requirements:

- The vehicle must have a valid certificate of insurance for private hire including proof of Public Liability insurance for a minimum of £5,000,000, throughout the licence period. Insurance stating covered for public hire will not be accepted for private hire vehicles.
- Certificates of insurance or cover notes issued to cover "any vehicle" or "any driver" must be accompanied by a schedule showing all the vehicles and drivers covered by the insurance as detailed in the certificate of insurance.
- Where a vehicle is insured by a proprietor and the proprietor allows another licensed Shropshire Council driver to drive their vehicle, or any vehicle is insured under a fleet insurance, the proprietor (as the policy holder) is responsible for ensuring that the driver of that vehicle is aware of the content of the policy, including its limitations and exclusions, and that the proprietor keeps records to this effect.
- Where an insurance cover note is provided a full certificate of insurance must be produced to the Council within 7 days of the certificate being received by the owner of the vehicle.

- The proprietor must also obtain information as to any requirement for them to have Employers Liability Indemnity; if there is such a requirement, it must be for a minimum of £1,000,000.

3e.82 With respect to a licensed vehicle, in the event that a proprietor fails to present to the Council a valid certificate of insurance as required (unless delayed or prevented by sufficient cause accepted and agreed by the Council), the Council may suspend the licence and require the proprietor of that private hire vehicle to return all the plates to the Council subject to any appeal period.

Vehicle compliance process

3e.83 Once an application has been validated and accepted a member of the Licensing Team will contact the applicant to arrange a vehicle compliance appointment. At the appointment a vehicle will be subject to a compliance check to ensure:

- That where the vehicle is sufficiently equipped for the provision of one reference wheelchair that the driver presenting the vehicle is capable of safely loading and securing the wheelchair into the vehicle (the vehicle, including seating, wheelchair restraint and ramp, will be photographed and the images held on the vehicle record file for future reference)
- That where fitted the meter seal is intact and the serial number matches the number provided in the meter calibration certificate. Where a meter seal has been tampered with and/or the serial number no longer matches a new certificate/report to confirm the vehicle is fitted with a taximeter in accordance with the requirements set out at paragraph 3e.53
- The vehicle has a full size spare wheel or space saver design wheel and the tools to change a wheel OR a contract with a mobile tyre replacement specialist
- At least one no smoking sign is on display in the vehicle
- That where a vehicle is wheelchair accessible a sign confirming the wheelchair accessibility is clearly displayed
- The drivers internal 'Vehicle Copy' of drivers badge is displayed ensuring that the licence details and photo are visible to passengers
- Where CCTV is fitted, a CCTV operating in this vehicle sign is on display in the vehicle

3e.84 Vehicle proprietors are required to return the existing licence plate (renewal/transfer vehicles only) at the compliance appointment. Where officers are satisfied that the vehicle meets the compliance checks, the new licence plates will be issued. If, however, the vehicle does not meet the compliance check, advice will be provided and a further appointment arranged.

Transfer of a licence (Change of vehicle)

3e.85 All requests to transfer a vehicle licence (change of vehicle) onto another vehicle will be treated as a new vehicle application (in accordance with the requirements set out at paragraphs 3e.43 to 3e.49).

3e.86 Where a proprietor has notified the Council that damage has occurred to a licensed vehicle, resulting in the transfer of licence to a temporary insurance replacement vehicle, proprietors will be required to provide evidence to demonstrate the damage which has occurred to the vehicle, i.e. insurance assessors report.

3e.87 Where a vehicle has sustained structural damage from a road traffic accident resulting in a DVLA classification under Category S – Structural damage (vehicle that has sustained damage after 1

October 2017) or Category C (vehicle has sustained damage, rendering it beyond economical repair, prior to 1 October 2017), any documents provided to meet the safety requirements of the policy as part of the previous application process (i.e. SVA certificate or IVA certificate) may be invalid. In these circumstances the Council will require the proprietor to submit the vehicle for a new basic voluntary IVA check and provide a valid IVA 6 certificate to the Licensing Team before the licence can be transferred back to the original vehicle.

3e.88 Where a wheelchair accessible vehicle has sustained damage that does not affect the validity of the documents provided to meet the safety requirements of the policy as part of the previous application process (i.e. VCA certificate, IAC or IVA 6), provided any repairs have been made by a garage approved and authorised by the insurance company, the Council will require the proprietor to submit confirmation from the insurance company that the repairs have been completed in accordance with the insurance assessors report and a new MOT certificate (in accordance with the requirements set out at paragraph 3e.77 above) to the Licensing Team before the licence can be transferred back to the original vehicle.

Vehicle not fit for the conveyance of passengers

3e.89 Where a proprietor has notified the Council that damage has occurred to a vehicle, otherwise than in accordance with relevant road traffic legislation, the Council may require photographic evidence of the damage or for the vehicle to be presented for inspection by an authorised officer of the Council.

3e.90 If the authorised officer determines that a vehicle is not fit for the purpose of conveying passengers an authorised officer of the Council may at that time suspend the licence and require the proprietor of the vehicle to return all the vehicles plates to the Council. The suspension will be lifted and the plate returned at such time when the condition of the vehicle is demonstrated, to the satisfaction of the Council, to be fit for conveying passengers.

3e.91 The officer may require the proprietor to arrange for a further MOT test, or in respect of wheelchair accessible vehicles a basic voluntary IVA test, to be undertaken and certificate produced before the vehicle will be permitted to operate; this is at the discretion of the authorised officer.

Use of information on and in relation to novelty private hire vehicles

3e.92 Proprietors may display advertisements, information, images and other material on novelty private hire vehicles in accordance with the conditions set out at **Appendix L**. This is subject to prior written approval from the Council.

Closed circuit television (CCTV)

3e.93 Proprietors of private hire vehicles are encouraged to install closed circuit television (CCTV) systems providing such systems are installed in accordance with the appropriate legal framework and the Council has been notified, in writing, of their intention to do so.

3e.94 Proprietors of private hire vehicles must register with the Information Commissioners Office (ICO) and maintain a valid registration throughout the duration of the licence or until such a time as the CCTV has been removed from the licensed vehicle.

Trailers

- 3e.95 Private hire vehicles licensed by the Council are permitted to tow trailers when undertaking the licensed activity providing that the conditions set out at **Appendix M** are complied with at all times.

Parking/waiting

- 3e.96 Where a driver is illegally parked or creating an obstruction, i.e. in contravention of road traffic legislation and traffic regulation orders (this does not include a legitimate period of time where a novelty private hire vehicle has stopped to drop off or pick up a fare), the driver's licence may be reviewed and such conduct may be deemed a reasonable cause to revoke or suspend the licence or to take any other appropriate action.

LPG converted vehicles

- 3e.97 The Council must be satisfied that any vehicle that has been converted to LPG has been converted correctly prior to a licence being issued. To this end, the Council will undertake checks with the UK LPG Vehicle Register.
- 3e.98 With respect to new applications, where it is established that a conversion has not been undertaken correctly and/or the vehicle is unsafe in any way, the Council will refuse the application.
- 3e.99 In the event that an LPG conversion has been undertaken on a vehicle during a current licensed period and the proprietor of the vehicle fails to notify the Council within 7 days of the conversion, an authorised officer of the Council will suspend the vehicle licence until such time evidence is available on the UK LPG Vehicle Register
- 3e.100 In the case of a conversion that has been undertaken on a vehicle during a current licensed period and it is subsequently established that the conversion has not been undertaken correctly and/or the vehicle is unsafe in any way, an authorised officer of the Council will suspend the licence until such time as the conversion has been undertaken correctly and/or it is demonstrated to the satisfaction of the Council that the vehicle is safe.

Production of records/documents

- 3e.101 Any records required to be retained in accordance with the licence and licence conditions must be produced, on request, to any authorised officer of the Council or to any police officer.

Licence conditions

- 3e.102 The applicable conditions relevant to a novelty private hire vehicle licence are set out at **Appendix F**; these conditions must be complied with. These conditions are in addition to any matters set out within the main body of the Policy.

Main legal requirements

- 3e.103 Paragraphs 3e.104 to 3e.111 is not exhaustive and unless otherwise specified please refer to the Local Government (Miscellaneous Provisions) Act 1976 for a full list of legal requirements, offences and the maximum penalty upon conviction.**

3e.104 Change of proprietor

The proprietor must give notice to the Council of any transfer in his interest in the private hire vehicle to a person other than the proprietor whose name is specified in the licence. Such notice must be given, in writing, within 14 days specifying the name and address of the person to whom the vehicle has been transferred.

3e.105 Inspection

The proprietor must present their private hire vehicle for inspection and testing by the Council as required, up to a maximum of 3 times during any one period of 12 months.

3e.106 The proprietor must provide, on request, the address where the private hire vehicle is kept and allow the Council to inspect and test the vehicle at that address.

3e.107 Accidents

The proprietor, notwithstanding their responsibilities under relevant road traffic legislation, must also report to the Council any accident as soon as reasonably practicable. However, where the vehicle has suffered accident damage that materially affects the safety, performance or appearance of the vehicle, or the comfort or convenience of fare paying passengers, the driver must notify the Council within 72 hours.

3e.108 Production of documents

The proprietor must, on request by an authorised officer of the Council or a police officer, produce to the officer for inspection the private hire vehicle licence and insurance certificate within 7 days.

3e.109 Return of identification plates

Where a licence is revoked, suspended or expires, the proprietor, when required by the Council to do so must return all the identification plates within 7 days.

3e.110 Transporting children

As a minimum, private hire vehicles must be capable of complying with the requirements set out in the table below, for further guidance see <https://www.gov.uk/child-car-seats-the-rules/when-a-child-can-travel-without-a-car-seat>.

	Front seat	Rear seat	Who is responsible?
Child up to 3 years	Correct child restraints must be used	Correct child restraint must be used. If a restraint is not available in a licensed hackney carriage or private hire vehicle, the child may travel unrestrained.	Driver**
Child from 3rd birthday to 12th birthday or 135 cm in height whichever they reach first	Correct child restraints must be used	Where seat belts are fitted, the correct child restraint must be used. The child must use adult belt if the correct child restraint is not available as follows: in a licensed hackney carriage or private hire vehicle; or for a short distance in an unexpected necessity; or two occupied child restraints prevent fitting of a third.	Driver**

		A child 3 years and over may travel unrestrained in the rear seat of a vehicle if seat belts are not fitted in the rear.	
Child over 135 cm in height or 12 or 13 years old	Seat belt must be worn if available*	Seat belt must be worn if available.	Driver**
Passengers aged 14 years and over	Seat belt must be worn if available*	Seat belt must be worn if available.	Passenger

*Vehicles built before 1965 are not required to have fitted seatbelts.

**Drivers must inform parents/carers that the decision to permit children to travel in the vehicle, without the correctly sized seat restraints (as permitted by relevant legislation) and with the obvious risks associated with such an action, remains with the parent/carer responsible for the children and not with the driver of the vehicle.

3e.111 Ranks/stands

A novelty private hire vehicle must not wait (stop or park) on any rank/stand.

Summary

- 3f.1 Private hire operators are licensed in accordance with the Local Government (Miscellaneous Provisions) Act 1976. Any person who wishes to take bookings, in the course of a business, for a private hire vehicle must hold a private hire operator licence.

Applicant

- 3f.2 All applicants (including sole traders, partnerships and companies) for a private hire operator licence must prove that they are a fit and proper person to hold an operator licence.

Fit and proper person

- 3f.3 Licensed private hire operators provide a public service and have a direct impact on public safety. On this basis, the Council will not licence anyone as a private hire operator unless it is satisfied that they meet all the criteria to be deemed a fit and proper person as set in **Appendix I**.

Applicants for a private hire operator licence who hold a valid Shropshire Council hackney carriage/private hire drivers licence

- 3f.4 The Council adopts the same principles when determining whether an applicant is a fit and proper person to hold a private hire operator licence as it does to persons applying for a drivers licence. In this respect, applicants are required to have due regard, as appropriate, to the requirements and information set out at paragraphs 3a.4 to 3a.24 of the Policy.

Applicants for a private hire operator licence who do not hold a valid Shropshire Council hackney carriage/private hire drivers licence

- 3f.5 In considering the fit and proper person test, all applicants on initial application must provide a basic criminal record disclosure from the Disclosure and Barring Service. All applicants on renewal must provide a basic criminal record disclosure that has been issued by the Disclosure and Barring Service within the previous 12 months of the date that the application is received by the Council. On new and renewal applications the Council will also make additional enquiries through its adults and childrens social care teams, directly with West Mercia Police (and other relevant police forces, where appropriate), other relevant local authorities (particularly Telford & Wrekin Council and City of Wolverhampton Council) and any other appropriate organisation, agency or person in order to ensure the Council is in a position to make as accurate an assessment of the applicant's fitness to hold a licence as is reasonably practicable.
- 3f.6 Once a licence has been granted an operator will be required to provide a basic disclosure for all partners, directors/company secretaries on an annual basis, unless the partner, directors/company secretary is a hackney carriage and private hire driver licensed by the Council.
- 3f.7 With specific reference to existing licence holders, where there is any cause for a licence to be reviewed, the Council will make additional enquiries through its adults and childrens social care teams, directly with West Mercia Police (and other relevant police forces, where appropriate), other relevant local authorities (particularly Telford & Wrekin Council and City of Wolverhampton Council) and any other appropriate organisation, agency or person in order to ensure the Council

is in a position to make as accurate an assessment of the licence holders fitness to hold a licence as is reasonably practicable. Depending on the circumstances of the case, the Council may request the licence holder to consent to a further basic criminal record disclosure, the cost of which lies with the licence holder. Where a licence holder refuses to consent to a further check the Council will take this into consideration in determining their continuing fitness to hold a licence.

- 3f.8 When assessing the fitness of an applicant to hold a private hire operators licence, the Council will consider the applicant's criminal history as a whole, together with all other relevant evidence, information and intelligence including their history (e.g. complaints and positive comments from the public, compliance with licence conditions and willingness to co-operate with licensing officers) whilst holding a licence from the Council or any other authority. Particular attention will be given to patterns of behaviour, irrespective of the time-scale over which they have occurred, both in terms of proven criminal offences and other behaviour/conduct that may indicate the safety and welfare of the public may be at risk from the applicant.
- 3f.9 In addition, an important element associated with the fitness to hold a licence is the appearance (be clean and respectable in their dress and person and maintain a high standard of personal hygiene) and behaviour of an applicant. Consequently, the Council requires all applicants to maintain a reasonable standard of appearance and behaviour when in contact and dealing with all persons, including but not limited to, other road users, pedestrians, customers, the general public, other licensed operators and drivers of hackney carriage and private hire vehicles, Council officers and elected members at all times. Applicants must also co-operate with any reasonable request made by an authorised officer of the Council or any police officer.
- 3f.10 It must also be recognised that the Council will consider all relevant criminal history, behaviour and conduct irrespective of whether the specific history, behaviour or conduct occurred whilst applicants were directly engaged in hackney carriage or private hire licensed work at the time or whether they occurred during the applicants' own personal time. The Council considers a person or individual who has a propensity to commit offences and/or demonstrate unacceptable conduct whilst not engaged in hackney carriage or private hire work to be equally as serious as offences and/or unacceptable conduct committed whilst engaged in hackney carriage or private hire work.

Criminal record disclosure

- 3f.11 All unspent convictions, including cautions, will be taken into account when considering a person's suitability to hold a licence. Consequently, applicants are required to provide details of all unspent convictions and cautions, including driving endorsements (driving convictions) and disqualification periods relating to traffic offences.
- 3f.12 Although cautions are generally not as serious as convictions, ordinarily as a result of the circumstances under which they are offered, they do require an admission of guilt before they can be issued which is equivalent to a guilty plea on prosecution. Consequently, a caution is regarded in exactly the same way as a conviction. Fixed penalties, community resolutions or similar sanctions will also be considered in the same way as a conviction on the basis that payment of a fixed penalty indicated an acceptance of guilt and a community resolution can only be imposed following an admission of guilt. As a result, each of these sanctions is a valuable indication as to an applicant's character and whether they are a fit and proper person to hold or be granted a licence.
- 3f.13 A criminal record does not automatically bar an applicant from holding a licence; however, it will be a significant factor when determining whether a licence ought to be granted or not. Where an

applicant has previous criminal convictions, these will be considered in line with the guidance set out in **Appendix I**. However, the over-riding consideration will always be to ensure the safety and welfare of the public.

- 3f.14 Persons who have not been resident within the United Kingdom for the five years prior to submitting an application, will be required to produce a certificate of good conduct or equivalent document (at their own cost) issued by the relevant Embassy or High Commission. The certificate must be authenticated, translated and sealed by the Embassy or High Commission. In the event that an applicant is not able to obtain a certificate of good conduct, they may submit a statutory declaration with regard to their conduct, which must be completed in the presence of a practising solicitor. The Council may contact the relevant Embassy, High Commission, solicitor or other appropriate body to verify any documents provided. Contact details for Embassies and High Commissions can be found from the Foreign, Commonwealth & Development Office (FCDO) on the GOV.UK website at <https://www.gov.uk/government/world>. The FCDO may be contacted for further assistance by telephone on 020 7008 5000, by email at fcdo.correspondence@fcdo.gov.uk or by post at the FCDO, King Charles Street, London, SW1A 2AH.
- 3f.15 Applicants who have spent three continuous months or more living outside the United Kingdom, during the period of their licence, will be required to produce a certificate of good conduct or equivalent document at their own cost. This certificate must be issued by the relevant Embassy or High Commission for the country or countries lived in during this period and meet the requirements as set out at 3f.14 above. It is recognised that some countries will not provide a certificate of good conduct unless the individual has been resident for six months or more. Where a relevant Embassy or High Commission refuse to issue a certificate of good conduct, applicants must provide written confirmation from the Embassy of any refusal to the Licensing Team.

Right to work

- 3f.16 The Immigration Act 2016 amended existing licensing requirements in the UK to prevent illegal working in the hackney carriage and private hire licensing trade. With effect from 1 December 2016, the provisions in the Immigration Act 2016 prohibits all licensing authorities across the UK from issuing a licence to anyone who is disqualified by reason of their immigration status.
- 3f.17 All applicants must provide evidence of their right to work in the UK in accordance with the Home Office requirements. For further information see: <https://www.gov.uk/government/publications/licensing-authority-guide-to-right-to-work-checks>.

HMRC tax check

- 3f.18 The Finance Bill 2021 introduced new tax check requirements for applicants for a private hire operators drivers licence. For further information see: <https://www.gov.uk/guidance/complete-a-tax-check-for-a-taxi-private-hire-or-scrap-metal-licence>.
- 3f.19 With effect from 4 April 2022, new applicants for a private hire operators licence, if applying for a licence for the first time, will be required to read HMRC guidance on their responsibilities and will be required to confirm via the application process that this has been done.
- 3f.20 Applicants applying to renew a private hire operators licence or new applicants that hold, or have held, a similar licence within the previous 12 months, will be subject to a tax check to demonstrate that they are registered for tax.

Non-conviction information

- 3f.21 In addition to conviction/caution information, applicants are expected to provide details, within 48 hours of all warnings, driving endorsements (driving convictions)/disqualification periods relating to traffic offences, fixed penalties, penalty charge notices, community resolutions and any other similar sanctions, together with any charges or arrests that they are the subject of in connection with criminal offences, whether or not actually charged with the offence, and details of any allegations of involvement in criminal activity or where they have been questioned in connection with any alleged criminal activity or inappropriate/unacceptable behaviour or any other relevant pending matter.
- 3f.22 Where an applicant is the subject of an outstanding charge or summons, their application may continue to be processed; however, depending on the circumstances, it is unlikely that a decision on the application will be made until the conclusion of the criminal proceedings. Where the outstanding charge or summons involves a serious offence and/or the individual's offending history and behaviour/conduct indicates a pattern of unlawful or unacceptable behaviour/character traits, then the application is likely to be refused.
- 3f.23 Where there is evidence/information that an applicant has been arrested or charged but not convicted of offences and the nature of this evidence/information suggests the applicant may not be a fit and proper person, the Council will give serious consideration to refusing an application or revoking an existing licence.

Period of licence

- 3f.24 Operator licences will be issued for a period of five years or for such lesser period as the Council think appropriate in the circumstances of the case.

Drivers of executive private hire vehicles

- 3f.25 Operators are encouraged to ensure that executive drivers undertake an advanced motoring qualification.

Use of executive private hire vehicles

- 3f.26 Executive private hire vehicles must only be used for executive service, which is defined as the provision of a vehicle or vehicles that is/are **exclusively** used for executive private hire work and **not** for 'normal' or general purpose private hire use.
- 3f.27 The type of work that is considered 'executive service' includes, but is not restricted to:
- Exclusive business to business contracts, i.e. to transport employees and clients on business related journeys under a written contract to a company or person.
 - Bookings for certain clients (for example politicians and celebrities) who, for security or personal safety reasons, would not want the vehicle to be identifiable as a private hire vehicle.
 - Bookings for certain clients who want to hire an executive vehicle at a premium rate, where the applicant can demonstrate that the vehicle is used solely for the purposes of this type of hire.

- 3f.28 Bookings taken in respect of clients who require an executive private hire must be paid for on account. No payment can be made to the driver of the vehicle at time of hiring.
- 3f.29 Operators must be able to demonstrate the vehicle will be used for executive service by providing written confirmation that the vehicle will only undertake executive service.

New application process

- 3f.30 The application form must be fully completed and include all relevant information, supporting documentation and appropriate fee.
- 3f.31 The full fee for the licence is payable at the time the application is submitted.
- 3f.32 If any part of the application form is incomplete or the relevant information or supporting documentation is not provided, the applicant will be requested to provide the missing information/documentation and informed that the application will not be processed until such time as all the information/documentation is provided. If the applicant fails to provide all the information to complete the application, the application will be rejected.
- 3f.33 Once an application has been accepted by the Licensing Team as a valid application the application process must be completed within 6 months unless prevented from doing so by matters that are outside the applicant's control. When an application is not completed within this timescale the application will be referred to the Licensing Panel for determination where an officer with delegated authority will consider each case on its own individual merits and will determine what action is appropriate and proportionate to the circumstances of the case.
- 3f.34 Any person (including a sole trader, partnership or company) wishing to become a licensed private hire operator must:
- Submit a completed application form (where the application relates to a partnership or a company, the application form must provide the name, address and date of birth of all partners, directors/company secretaries, as appropriate)
 - Submit a completed reference form, unless the applicant is the holder of a hackney carriage and private hire drivers licence or private hire operator licence issued by Shropshire Council (NB the referees must be from either professional or business sources who have known the applicant for at least two years. In addition, the Council will not accept references from family members, drivers, operators, vehicle proprietors licensed with any local authority or, where relevant, the applicant's future employer unless there is satisfactory evidence of exceptional circumstances that are accepted by the Council). The Council reserves the right to refuse a reference where the Council deems the referee is not acceptable
 - Pay the appropriate licence fee
 - Provide evidence of their right to work in the UK in accordance with the Home Office requirements (where the application relates to a partnership or a company, the evidence must be provided for all partners, directors/company secretaries, as appropriate – for additional information see <https://www.gov.uk/government/publications/licensing-authority-guide-to-right-to-work-checks>)
 - Provide a basic criminal record disclosure from the Disclosure and Barring Service, unless the applicant is the holder of a hackney carriage and private hire drivers licence issued by Shropshire Council (applicants can apply to <https://www.gov.uk/request-copy-criminal-record>). A basic criminal record disclosure will only be accepted by the Council within 12 months of the date of issue from the Disclosure and Barring Service

- Provide proof that the person nominated in the application form as the Designated Person (DP) has completed the Council's hackney carriage and private hire drivers and operators safeguarding and disability awareness course, unless the nominated DP is the holder of a hackney carriage and private hire drivers licence issued by Shropshire Council and has completed the Councils safeguarding and disability awareness course in the previous two years
- Provide a business plan/model; a business plan/model should include, but is not restricted to, a description of your business, premises location plan, competitive environment, a marketing plan, information on how you intend to grow/sustain the business and any other relevant information about how you will operate as a business
- Provide a policy on employing ex-offenders which meets the requirements set out in Appendix G, paragraphs 1.6 to 1.8
- Provide the proposed company advertisements, information, images and other material, including branding/logo

3f.35 Once an application has been validated and accepted, the Council will:

- Make enquiries through the Councils adults and childrens social care teams, West Mercia Police (or other relevant force), other local authorities and any other organisation, agency or person that the Council has deemed appropriate to seek information from
- Where applicable, write to the referees provided
- Arrange an inspection of the operators business premises
- Where applicable, complete an online tax registration check

3f.36 **NB** For partnerships or companies, the requirements set out in paragraphs 3f.2 to 3f.23 apply to all partners and directors/company secretaries.

3f.37 Providing the above are satisfied and there are no other concerns about the application, Officers will grant the licence. In all other cases, the application will be referred to the Licensing Panel for determination. Each application will be decided on its merits. However, there is a presumption that unless an applicant can demonstrate exceptional circumstances the application will be refused. Whilst it is neither possible nor prudent to draw up a list of what might amount to exceptional circumstances, an applicant who claims that exceptional circumstances exist will be expected to be able to satisfy the Council that it would not frustrate the purposes of this Policy or compromise public safety if the licence were granted. The applicant will be notified in writing if their application is to be determined at a meeting of the Licensing Panel.

Renewal of a licence

3f.38 To allow the operators licence to be renewed, a renewal application form must be received by the Council at least 10 working days prior to the expiry date of the original licence (unless there is satisfactory evidence of exceptional circumstances that are accepted by the Council) to allow the Council sufficient time to process the renewal application. It is the Council's intention to process all valid renewal applications within 10 working days; hence, where applicants fail to submit their renewal application within this timescale, the risk that their licence will expire increases. Once a licence expires, is revoked (subject to a statutory appeal process) or surrendered, it ceases to exist and applicants would not be permitted to take any bookings for, or dispatch any, private hire vehicles in these circumstances.

3f.39 Once a licence ceases to exist a renewal application will not be accepted by the Council (unless there is satisfactory evidence of exceptional circumstances that are accepted by the Council) and

the applicant must submit a new private hire operators licence application which will be processed in accordance with the Council's new application procedures.

Renewal application process

- 3f.40 The application form must be fully completed and include all relevant information, supporting documentation and appropriate fee.
- 3f.41 The full fee for the licence is payable at the time the application is submitted.
- 3f.42 If any part of the application form is incomplete or the relevant information or supporting documentation is not provided, the applicant will be requested to provide the missing information/documentation and informed that the application will not be processed until such time as all the information/documentation is provided. If the applicant fails to provide all the information to complete the application, the application will be rejected.
- 3f.43 Once an application has been accepted by the Licensing Team as a valid application the application process must be completed within 6 months unless prevented from doing so by matters that are outside the applicant's control. When an application is not completed within this timescale the application will be referred to the Licensing Panel for determination where an officer with delegated authority will consider each case on its own individual merits and will determine what action is appropriate and proportionate to the circumstances of the case.
- 3f.44 Any person (including a sole trader, partnership or company) wishing to renew a private hire operator licence must:
- Submit a completed application form (where the application relates to a partnership or a company, the application form must provide the name, address and date of birth of all partners, directors/company secretaries, as appropriate)
 - Pay the appropriate licence fee
 - Provide evidence of their right to work in the UK in accordance with the Home Office requirements (where the application relates to a partnership or a company, the evidence must be provided for all partners, directors/company secretaries, as appropriate – for additional information see <https://www.gov.uk/government/publications/licensing-authority-guide-to-right-to-work-checks>)
 - Provide a basic criminal record disclosure from the Disclosure and Barring Service, unless the applicant is the holder of a hackney carriage and private hire drivers licence issued by Shropshire Council (applicants can apply to <https://www.gov.uk/request-copy-criminal-record>). A basic criminal record disclosure will only be accepted by the Council within 12 months of the date of issue from the Disclosure and Barring Service
 - Provide proof that the person nominated in the application form as the Designated Person (DP) has completed the Council's hackney carriage and private hire drivers and operators safeguarding and disability awareness course
 - Provide a list of the vehicles and drivers which they operate
 - Provide a policy on employing ex-offenders which meets the requirements set out in Appendix G, paragraphs 1.6 to 1.8
- 3f.45 Once an application has been validated and accepted, the Council will:

- Make enquiries through the Councils adults and childrens social care teams, West Mercia Police (or other relevant force), other local authorities and any other organisation, agency or person that the Council has deemed appropriate to seek information from
- Arrange an inspection of the operators business premises
- Complete an online tax registration check

3f.46 **NB** For partnerships or companies, the requirements set out in paragraphs 3f.2 to 3f.23 apply to all partners and directors/company secretaries.

3f.47 Providing the above are satisfied and there are no other concerns about the application, Officers will grant the licence. In all other cases, the application will be referred to the Licensing Panel for determination. Each application will be decided on its merits. However, there is a presumption that unless an applicant can demonstrate exceptional circumstances the application will be refused. Whilst it is neither possible nor prudent to draw up a list of what might amount to exceptional circumstances, an applicant who claims that exceptional circumstances exist will be expected to be able to satisfy the Council that it would not frustrate the purposes of this Policy or compromise public safety if the licence were granted. The applicant will be notified in writing if their application is to be determined at a meeting of the Licensing Panel.

Contracting of private hire drivers and employment of other staff

3f.48 An operator is deemed to be responsible for the actions of any manager, supervisor, office based administrative and telephony staff, contracted private hire drivers or any other person appointed to run or play any part in the private hire operator business, whilst undertaking work for or behalf of the operator.

3f.49 An operator must take reasonable, appropriate and robust steps to reduce to a minimum the risk of employing or being employed by, engaging in partnership with, or allowing any involvement in the licensed operation any person who is unlikely to satisfy the Council's 'fit and proper person' test and therefore an operator must have regard to the information in paragraphs 3a.4 to 3a.24 of this Policy.

3f.50 An operator must take all reasonable, appropriate and robust steps to reduce to a minimum the risk of allowing any involvement in the licensed operation any person who may be working in 'regulated activity' as defined by the Safeguarding Vulnerable Groups Act 2006. It is an offence for an operator to knowingly allow a barred individual to work in regulated activity.

3f.51 An operator must make and retain individual records of the steps they have taken to demonstrate how they are satisfied that an individual, including all private hire drivers, managers, office based administrative and telephony staff and agency staff, is a fit and proper person. These steps must include, but are not restricted to:

- Face to face interviews with individuals
- Checks to ensure that the information provided by applicants is verified
- Independent professional and character references are requested and scrutinised
- Identity checks, right to work in the UK checks, national insurance number checks and relevant qualifications checks (if any) are verified as original documents
- Checks on previous employment history and experience
- Steps that are taken to verify that the individual has the health and physical capacity for the role

- A record of any discrepancies or anomalies, how they have been investigated and satisfactorily resolved

- 3f.52 An operator is responsible for ensuring that all new managers, office based administrative and telephony staff and agency staff²³ have undertaken a basic criminal record check from the Disclosure and Barring Service (applicants can apply to <https://www.gov.uk/request-copy-criminal-record>) in order to satisfy the Council's 'fit and proper person' test as set out in **Appendix I**.
- 3f.53 An operator is responsible for ensuring that all managers, office based administrative and telephony staff and agency staff continue to satisfy the 'fit and proper' test and where they have spent three continuous months or more living outside the United Kingdom, during the period of their employment, operators must ensure that each member of staff produces a certificate of good conduct or equivalent document at their own cost. This certificate must be issued by the relevant Embassy or High Commission for the country or countries lived in during this period. The operator must retain the certificate on an individual's record file. It is recognised that some countries will not provide a certificate of good conduct unless the individual has been resident for six months or more. Where a relevant Embassy or High Commission refuse to issue a certificate of good conduct, written confirmation from the Embassy of any refusal must be provided to the operator.
- 3f.54 An operator is responsible for ensuring that all private hire drivers and employees are made aware of and fully understand the meaning of 'plying for hire' and, in particular, that private hire drivers are NOT permitted to 'ply for hire' under any circumstances. The Council's interpretation of 'plying for hire' is set out at **Appendix H** and is based on relevant legislation and case law.
- 3f.55 An operator is responsible for ensuring that all private hire drivers, managers, office based administrative and telephony staff and agency staff have undertaken training in the General Data Protection Regulations (GDPR) and the Equality Act 2010.
- 3f.56 An operator is responsible for ensuring that all managers, office based administrative and telephony staff and agency staff have undertaken training in awareness of child, young persons and adults (including those with care and support needs) related exploitation (including sexual exploitation), hate crime, equalities, in particular as it relates to disabilities, and modern day slavery and trafficking.
- 3f.57 An operator is responsible for ensuring that all managers, office based administrative and telephony staff and agency staff afford all customers and prospective customers the highest level of customer service and care.
- 3f.58 An operator is responsible for ensuring that all private hire drivers, managers, office based administrative and telephony staff and agency staff are fully aware that their individual training records file will be made available, on request, to an authorised officer of the Council or to a police officer.
- 3f.59 An operator is responsible for ensuring drivers do not work excessively long hours and put the safety of themselves and their passengers at risk. The Council strongly recommends that operators monitor the hours that a driver works and ensures adequate breaks and rest periods are taken. To this end, operators must have regard to the European Union (EU) rules on driver hours and working time.

²³ Operators are responsible for ensuring that the agency has undertaken the necessary checks to satisfy the requirements of 3f.52

Designated person

- 3f.60 Operators must have a suitably trained Designated Person (DP) with specific responsibility for safeguarding and promoting matters of equality, through relevant policies.
- 3f.61 The DP is responsible for ensuring:
- That they are available to receive any matters of concern which may relate to the safety of children, young persons and adults (including those with care and support needs)
 - A record is maintained of all matters of concern received and the action taken
 - That they actively promote equalities in general and specifically in relation to hate crime and disability matters
 - That any matters of concern reported to them are forwarded to the relevant authorities
- 3f.62 Operators must ensure that the DP completes the Council's hackney carriage and private hire drivers and operators safeguarding and disability awareness course.
- 3f.63 Unless the DP is the holder of a hackney carriage and private hire drivers licence issued by Shropshire Council and required to complete the training as part of the driver application process, operators are responsible for ensuring that the DP satisfactorily completes a safeguarding and disability awareness course every two years.
- 3f.64 Where a new person is appointed as a DP, the operator is responsible for ensuring that the new DP completes the Council's hackney carriage and private hire drivers and operators safeguarding and disability awareness course within six weeks of commencement in the role of DP, unless the new DP is the holder of a hackney carriage and private hire drivers licence issued by Shropshire Council and required to complete the training as part of the driver application process.
- 3f.65 Failure to complete this training, in accordance with the requirements of paragraphs 3f.62 to 3f.64 above, will permit the Council to refuse to grant/refuse to renew a private hire operator licence or, in the case of an existing licence, will result in the matter being referred to a meeting of the Licensing Panel for a decision as to whether the private hire operator licence ought to be suspended or revoked.

Operator trading name and telephone number

- 3f.66 An operator's name and/or trade name must be approved by the Council. This name will appear on the operator's licence issued by the Council.
- 3f.67 The name must not include the words 'taxi' or 'cab' in the singular or plural or the word 'hire' unless the word 'hire' forms part of the trading name.
- 3f.68 An operator may only include the word 'executive' in the trading name where the operator provides an executive service with licensed executive private hire vehicles.
- 3f.69 An operator must provide a telephone number to be used for the receipt of bookings. This telephone number will appear on the operator's licence issued by the Council.

Use of information on and in relation to hackney carriages and private hire vehicles

- 3f.70 Operators may display advertisements, information, images and other material on private hire vehicles in accordance with the conditions set out at **Appendix L**. This is subject to prior written approval from the Council.
- 3f.71 Operators are encouraged to ensure that any private hire vehicle being dispatched by them displays the operator's name and/or trade name, as approved by the Council.
- 3f.72 Any advertising/promotion of the operators business must be in accordance with the conditions set out in **Appendix L**. This is subject to prior written approval from the Council. Artwork must be submitted with the application.

Operator premises

- 3f.73 The Council will grant an operator licence in the absence of the appropriate planning consent required to operate the business; however, applicants are strongly advised to demonstrate to the Council that they do have/are obtaining the appropriate planning consent if required.
- 3f.74 The Council will only grant operator licences applicable to the physical premises from which the operator business will be run.
- 3f.75 The Council will not grant an operator licence to apply to any physical premises that falls outside the administrative area of Shropshire Council.
- 3f.76 All requests to transfer the business address to a new premises will be treated as a new private hire operator application (in accordance with the requirements set out at paragraphs 3f.30 to 3f.36).

NB An operator is not permitted to take bookings at or to dispatch vehicle from the new premises until the application has been processed and a licence granted.

- 3f.77 There are a number of specific conditions set out in the operator licence conditions that apply to premises. Operators must be particularly mindful of complying with these and should they fail to do so the Council will consider suspending or revoking the operator licence.

Insurance

- 3f.78 Any premises that provide access to members of the public must be covered by Public Liability insurance for a minimum of £5,000,000.
- 3f.79 The operator must also obtain information as to any requirement for them to have Employers Liability Indemnity; if there is such a requirement, it must be for a minimum of £1,000,000.
- 3f.80 Where any vehicle is insured under a fleet insurance, an operator (as the policy holder) is responsible for ensuring that the driver of that vehicle is aware of the content of the policy, including its limitations and exclusions, and that they keep records to this effect.

Standards of service

- 3f.81 The Council is concerned to ensure the safety and protection of consumers.

- 3f.82 The Council considers that where the hirer of a private hire vehicle has booked a journey through a Shropshire Council licensed operator, it is the hirer's intention that a Shropshire Council licensed vehicle will fulfil this booking.
- 3f.83 Operators have a duty to ensure that their fare structure is transparent and made available. Operators are encouraged to inform customers, at the point of booking, and prior to the booking being accepted as to the fare that will be charged for the journey.

Record keeping

- 3f.84 Operators must keep records in accordance with the conditions attached to their licence. The conditions of licence as detailed in **Appendix G**, paragraphs 1.56 to 1.58 are associated with bookings made by telephone, online, app, Interactive Voice Response (IVR) or other electronic means, e.g. "taxi butler". If an operator intends to use an alternative booking system the requirements of paragraphs 1.47 to 1.58 still apply.
- 3f.85 Such records must be produced when requested by an authorised officer of the Council or a police officer. Operators must produce, when requested by an authorised officer of the Council or a police officer, any information necessary to assist in the prosecution of criminal offences, e.g. witness statement.

Vehicle not fit for the conveyance of passengers

- 3f.86 Where an operator has notified the Council that damage has occurred to a vehicle, otherwise than in accordance with relevant road traffic legislation, the Council may require photographic evidence of the damage or for the vehicle to be presented for inspection by an authorised officer of the Council.

Closed circuit television (CCTV)

- 3f.87 Operators are encouraged to install closed circuit television (CCTV) systems in premises to which the public have access to make bookings or to wait providing such systems are installed in accordance with the appropriate legal framework and the Council has been notified, in writing, of their intention to do so.
- 3f.88 Operators must register with the Information Commissioners Office (ICO) and maintain a valid registration throughout the duration of the operators licence or until such a time as the CCTV system has been removed from the premises.

Disabled passengers: Operator requirements

- 3f.89 Operators have a responsibility to ensure that any Shropshire Council licensed driver is made aware of their duties in respect of carrying disabled persons where:
- The hackney carriage or private hire vehicle is not included on a list of designated wheelchair accessible vehicles and where the passenger is disabled, including wheelchair users (with the assumption that the wheelchair user transfers to a passenger seat to travel)
 - The hackney carriage or private hire vehicle is included on the list of designated wheelchair accessible vehicles and where the passenger is disabled but not in a wheelchair, and that

- Failure to comply with those duties is a criminal offence under section 164A of the Equality Act 2010

Disabled passengers - Assistance to identify and find vehicle: Operator requirements

- 3f.90 Operators have a responsibility to ensure that appropriate questions are asked at the booking stage as to whether a passenger requires assistance and, if so, what form of assistance is required, for example, asking questions about the size of any wheelchair so that an appropriate sized vehicle can be allocated to the booking.
- 3f.91 Operators should not attempt to identify a persons impairment or disability, only what type of assistance the driver needs to provide in order for the passenger to board, travel in and alight from the vehicle in safety and reasonable comfort.
- 3f.92 Operators have a responsibility to ensure that all relevant information is passed on the driver at the point of allocation of the booking and prior to commencement of the journey.

Disabled passengers in wheelchairs: Operator requirements

- 3f.93 Operators have a responsibility to ensure that any Shropshire Council licensed driver who drives one of their wheelchair accessible vehicles is made aware of their duties in respect of carrying disabled persons in wheelchairs when driving a designated wheelchair accessible vehicle and failure to comply with those duties is a criminal offence under section 165 of the Equality Act 2010.

List of Designated Wheelchair Accessible Vehicles

- 3f.94 Section 167 of the Equality Act 2010 requires all local authorities to maintain a list of designated wheelchair accessible vehicles.
- 3f.95 All wheelchair accessible vehicles will be included within the Council's list of designated wheelchair accessible vehicles, unless the vehicle has been subject to a successful appeal against the decision to be included on the list.
- 3f.96 The list will contain details of the make and model of the vehicle and will state the operator name.

Licence conditions

- 3f.97 Applicable conditions relevant to a private hire operator licence are set out at **Appendix G**. These conditions must be complied with.

Main legal requirements

- 3f.98 Paragraphs 3f.99 to 3f.102 is not exhaustive and unless otherwise specified please refer to the Local Government (Miscellaneous Provisions) Act 1976 for a full list of legal requirements, offences and the maximum penalty upon conviction.**

3f.99 Contract

Every contract for the hire of a private hire vehicle is deemed to be made with the operator who accepted the booking for that vehicle whether or not the operator provided the vehicle or sub-contracted the booking.

3f.100 Production of records/documents

Any records required to be retained in accordance with the licence must be produced, on request, to any authorised officer of the Council or to any police officer. The operator licence must also be produced if requested.

3f.101 All original supporting documentation provided upon application must be retained for the duration of the licence period and must be produced, on request, to any authorised officer of the Council or to any police officer.

3f.102 Transporting children

As a minimum, operators must ensure the vehicles they operate are capable of complying with the requirements set out in the table below, for further guidance see <https://www.gov.uk/child-car-seats-the-rules/when-a-child-can-travel-without-a-car-seat>.

	Front seat	Rear seat	Who is responsible?
Child up to 3 years	Correct child restraints must be used	Correct child restraint must be used. If a restraint is not available in a licensed hackney carriage or private hire vehicle, the child may travel unrestrained.	Driver**
Child from 3rd birthday to 12th birthday or 135 cm in height whichever they reach first	Correct child restraints must be used	Where seat belts are fitted, the correct child restraint must be used. The child must use adult belt if the correct child restraint is not available as follows: in a licensed hackney carriage or private hire vehicle; or for a short distance in an unexpected necessity; or two occupied child restraints prevent fitting of a third. A child 3 years and over may travel unrestrained in the rear seat of a vehicle if seat belts are not fitted in the rear.	Driver**
Child over 135 cm in height or 12 or 13 years old	Seat belt must be worn if available*	Seat belt must be worn if available.	Driver**
Passengers aged 14 years and over	Seat belt must be worn if available*	Seat belt must be worn if available.	Passenger

*Vehicles built before 1965 are not required to have fitted seatbelts.

**Drivers must inform parents/carers that the decision to permit children to travel in the vehicle, without the correctly sized seat restraints (as permitted by relevant legislation) and with the obvious risks associated with such an action, remains with the parent/carer responsible for the children and not with the driver of the vehicle.

PART 4

**COMPLIANCE,
ENFORCEMENT AND
COMPLAINTS**

PART 4 – COMPLIANCE, ENFORCEMENT AND COMPLAINTS

Summary

- 4.0 This part of the Policy sets out the manner in which the Council approaches compliance and enforcement, including the way in which complaints will be dealt with, as it relates to hackney carriage and private hire licensing.

Compliance and enforcement

- 4.1 The Council's licensing officers will work closely with the hackney carriage and private hire trades to achieve compliance with this Policy, relevant legislation and the Council's conditions of licence. The Council will do so in accordance with the Council's Better Regulation and Enforcement Policy, which is available on the Council's website at <http://shropshire.gov.uk/shropshire-council/policies/>. In addition, hackney carriage and private hire vehicle drivers and operators must comply with all reasonable requests made by officers of Shropshire Council or any other relevant local authorities (particularly Telford & Wrekin Council and City of Wolverhampton Council) and the police. Failure to do so may lead to the suspension or revocation of a drivers licence, vehicle licence or private hire operator licence.
- 4.2 The Council will work closely with other enforcement authorities, particularly Telford & Wrekin Council and City of Wolverhampton Council, when dealing with licensed and unlicensed vehicles and drivers, particularly concerning cross-boundary related issues.
- 4.3 If the Council receives information in relation to any safeguarding or road safety concerns about a hackney carriage or private hire driver who is licensed by another licensing authority, the relevant information will be shared with that authority.
- 4.4 Licence holders are strongly encouraged to cooperate with authorised officers of the Council, officers from all other local authorities and any police officer. Failure to cooperate may lead to the suspension or revocation of a drivers licence, vehicle licence or private hire operator licence.

Complaints

- 4.5 Where appropriate, complainants will be encouraged to raise complaints with the relevant licence holder or business concerned. However, the Council will also respond to complaints in line with its Better Regulation and Enforcement Policy and will use complaint information to assist in the determination of licensing decisions.
- 4.6 Individuals or persons wishing to make a complaint relating to the service provided by the hackney carriage and/or private hire trade can do so by contacting the Licensing Team:

Website: <http://shropshire.gov.uk/licensing/licensing-types/taxis/>

Email: taxis@shropshire.gov.uk

Tel: 0345 678 9046

PART 5

CONSULTATION

PART 5 – CONSULTATION

1.0 Members of the public were invited to put forward their comments to the proposed policy document during a series of consultation periods. In addition, consultation was undertaken with the following stakeholders and partners:

- Hackney carriage and private hire drivers, proprietors and operators
- Competition and Markets Authority
- Oswestry Access Group
- Shropshire Disability Network
- West Mercia Police
- Shropshire Fire and Rescue Service
- Shropshire Council Adult Safeguarding
- Shropshire Council Children Safeguarding
- Neighbourhood Authority Working Group (which includes Telford & Wrekin Council and City of Wolverhampton Council)
- Regional Taxi Licensing Forum
- Local Business Board
- Business Improvement District (BID)
- Chamber of Commerce
- Federation of Small Businesses
- Campaign for Better Transport
- Shropshire Town and Parish Councils
- Team Shrewsbury
- Shropshire Council Regulatory Services and Trading Standards & Licensing managers
- Shropshire Council Passenger Transport Team
- Director of Public Health
- Assistant Director of Homes and Communities

PART 6

LICENSING CONTACT DETAILS

PART 6 – LICENSING CONTACT DETAILS

Contact details

6.0 For information, advice and guidance relating to hackney carriage and private hire licensing please contact:

Licensing
Business and Consumer Protection

Tel: 0345 678 9046

Email: taxis@shropshire.gov.uk

Website: <http://shropshire.gov.uk/licensing/licensing-types/taxis/>

Licence Fee Payments

6.1 Payments for licensing related fees can be made:

- Telephone: 0345 678 9046
- Online: <https://www.shropshire.gov.uk/pay/>

APPENDICES

APPENDIX A

**SAFEGUARDING OF
CHILDREN, YOUNG
PERSONS AND ADULTS
(INCLUDING THOSE
WITH CARE AND
SUPPORT NEEDS)**

SAFEGUARDING OF CHILDREN, YOUNG PEOPLE AND ADULTS (INCLUDING THOSE WITH CARE AND SUPPORT NEEDS)

Introduction

- 1.0 Set out below is information for hackney carriage and private hire drivers, vehicle proprietors and operators to help them report, to the relevant authorities, matters of concern that could relate to the safety of children, young people and adults (including those with care and support needs), particularly as it relates to exploitation, which includes sexual exploitation, criminal exploitation, modern slavery (including human trafficking), financial exploitation and radicalisation, as well as other forms of abuse, such as neglect, emotional abuse, sexual abuse, physical abuse etc.

General information

- 1.1 Shropshire Council's Licensing Service is helping to tackle exploitation and abuse by working together with key partners, particularly West Mercia Police, Children's and Adult Services within the Council and the Shropshire Safeguarding Community Partnership²⁴. The Partnership also works with the police, children's and adults social care, schools, health services and the youth offending team, as well as specialist child exploitation organisations such as the National Working Group (NWG) Network.
- 1.2 Through agencies working together and sharing information, we aim to identify and prevent exploitation and abuse to protect children, young people and adults (including those with care and support needs) and disrupt the activities in order to prosecute perpetrators of abuse.
- 1.3 Intelligence about perpetrators and locations of concern is crucial to help build up a picture of exploitation and abuse in Shropshire. This allows West Mercia Police and Children's and Adult Services to work together to safeguard children, young people and adults (including those with care and support needs) and make our communities a safer place to live.

Definition of a child or young person

- 1.4 A child is defined as anyone who has not yet reached their 18th birthday. A young person is a child who is aged 14 or over but not yet reached their 18th birthday.

Definition of an adult with care and support needs

- 1.5 An adult with care and support needs is someone who is in need of community care services due to disability, age or illness. They may be unable to take care of or protect themselves against significant harm or exploitation.

Exploitation

- 1.6 Exploitation is a form of abuse. It occurs where an individual or group takes advantage of an imbalance of power to coerce, manipulate or deceive a child, young person or adult (including those with care and support needs) into any activity that results in financial or other advantage

²⁴ Further information about Shropshire's Safeguarding Community Partnership can be found at: <http://www.safeguardingshropshireschildren.org.uk/>

for the perpetrator or facilitator. Specific types of exploitation include sexual exploitation, criminal exploitation, modern slavery (including human trafficking), financial exploitation and radicalisation.

- 1.7 Multiple types of exploitation can occur alongside one another or as part of other forms of abuse.
- 1.8 The child, young person or adult (including those with care and support needs) may still be exploited even if the activities that they are engaging in appear consensual.
- 1.9 Exploitation is a crime that can affect any child, young person or adult (including those with care and support needs) anytime, anywhere – regardless of their social or ethnic background.

Child criminal exploitation

- 1.10 Child criminal exploitation (CCE) is common in county lines and occurs where an individual or group takes advantage of an imbalance of power to coerce, control, manipulate or deceive a child or young person under the age of 18 into any criminal activity:
 - in exchange for something the child or young person needs or wants; and/or
 - for the financial or other advantage of the perpetrator or facilitator (such as to support serious crime and/or terrorism); and/or
 - through violence or the threat of violence to ensure compliance.
- 1.11 The child or young person may have been criminally exploited even if the activity appears consensual. Child criminal exploitation does not always involve physical contact; it can also occur through the use of technology.
- 1.12 Criminal exploitation of children or young people could include being forced to work on cannabis farms, coerced into moving drugs across the country, made to beg, shoplift or pickpocket, made to threaten others, etc.

Child sexual exploitation

- 1.13 Child sexual exploitation (CSE) is a form of sexual abuse where an individual or a group of people takes advantage of an imbalance of power to coerce, manipulate or deceive a child or young person into sexual activity:
 - in exchange for something the child or young person needs or wants, including necessities such as food, shelter, alcohol, drugs, money, affection or protection; and/or
 - for the financial advantage or increased status of the perpetrator or facilitator; and/or
 - where an individual has felt frightened of the consequences if they refuse (coercion).
- 1.14 Child sexual exploitation involves perpetrators grooming youngsters into thinking they are in an intimate relationship, leading the child or young person to feel safe and protected if they engage in sexual acts.
- 1.15 The child or young person may have been sexually exploited even if the activity appears consensual. Child sexual exploitation does not always involve physical contact; it can also occur through the use of technology.

Modern slavery

- 1.16 Modern slavery is a crime and a violation of fundamental human rights and can take various forms such as human trafficking, slavery, servitude, forced and compulsory labour.
- 1.17 Victims are forced, threatened or deceived into situations of subjugation, degradation and control which undermine their personal identity and sense of self.
- 1.18 If you notice a house in your street where suddenly large numbers of young women have been moved in and which then receives visitors all times of day and night; a café, nail bar or car wash where workers seem reticent to engage, not appropriately dressed for their work or increasingly ill fed and unkempt, this could be a sign of modern slavery. Report something suspicious you spot to the police or other authorities.

How hackney carriage and private hire vehicle drivers and private hire operators and vehicle proprietors can help tackle exploitation and abuse

- 1.19 Safeguarding children, young people and adults (including those with care and support needs) is everyone's business and everyone's responsibility.
- 1.20 Drivers of hackney carriages and private hire vehicles as well as private hire operators and vehicle proprietors are in a good position to help identify victims of exploitation and abuse because, through the transport services they provide, drivers, operators and vehicle proprietors regularly come into contact with children, young persons and adults (including those with care and support needs). This means that hackney carriage and private hire vehicle drivers and private hire operators and vehicle proprietors are in an ideal position to help protect people.
- 1.21 In particular, drivers, proprietors and operators should ask themselves the following questions when picking up a fare or accepting a booking where they suspect the passenger may be a victim of exploitation or abuse:
- Does your customer appear to be under 18 years old?
 - Who made the booking on behalf of the customer?
 - Are they with a much older person and appear to be in a relationship?
 - Do you think that they are under the influence of alcohol or drugs?
 - Are you taking them to a hotel, party or secluded location? If so, ask yourself why?
 - Are children/young people or adults (including those with care and support needs) being taken regularly to the same localities? If so, ask yourself why?
 - Has your customer got any physical signs of abuse or neglect?
 - Are they a regular customer? Do you see changes in their behaviour or mood?
 - Has the customer told you they are having difficulties with someone else?
 - Has the customer told you they are worried about someone?
 - Has the customer told you they have hurt a person?
 - Has the customer told you something they have seen or heard?
 - Do you know something that causes concern about someone else's welfare?
 - Have you seen worrying behaviour towards someone?
- 1.22 **If the answers to any of the questions above gives you even the slightest cause for concern, these concerns should be reported.**

- 1.23 If you have reason to suspect that a child or young person is being exploited or at risk of abuse it is your responsibility to report your concerns to and share information with West Mercia Police (Tel: 101) and Children’s Social Care (Tel: 0345 678 9021).**
- 1.24 If you have reason to suspect that an adult is being exploited or at risk of abuse it is your responsibility to report your concerns to and share information with West Mercia Police (Tel: 101).**
- 1.25 Where these concerns relate to an adult with care and support needs who lives in the administrative area of Shropshire Council, it is your responsibility to contact the First Point of Contact team on 0345 678 9044, Monday to Thursday 9am to 5pm, and Friday 9am to 4pm. If you have an adult safeguarding concern outside of these hours, please phone the Emergency Social Work Duty Team on 0345 678 9040.**
- 1.26 In an emergency contact the police (999) or non-emergency 101.**
- 1.27 When picking up a fare or accepting a booking drivers, proprietors and operators should ask themselves the following questions where they suspect the passenger may be a victim of modern slavery:**
- Is the victim in possession of a passport, identification or travel documents? Are these documents in possession of someone else?
 - Does the victim act as if they were instructed or coached by someone else? Do they allow others to speak for them when spoken to directly?
 - Was the victim recruited for one purpose and forced to engage in some other job? Was their transport paid for by facilitators, whom they must pay back through providing services?
 - Does the victim receive little or no payment for their work? Is someone else in control of their earnings?
 - Was the victim forced to perform sexual acts?
 - Does the victim have freedom of movement?
 - Has the victim or family been threatened with harm if the victim attempts to escape?
 - Is the victim under the impression they are bonded by debt, or in a situation of dependence?
 - Has the victim been harmed or deprived of food, water, sleep, medical care or other life necessities?
 - Can the victim freely contact friends or family? Do they have limited social interaction or contact with people outside their immediate environment?
- 1.28 If the answers to any of the questions above gives you even the slightest cause for concern, these concerns should be reported.**
- 1.29 If there is an immediate danger to the suspected victim or if you think that the suspected victim is under 18, inform the police and call 999 as a matter of urgency.**
- 1.30 Call the Modern Slavery Helpline on 0800 0121 700**
- 1.31 For England and Wales, you can call the 24-hour confidential referral helpline on 0800 808 3733 anytime of the day or night to refer a victim of trafficking or receive advice.**

APPENDIX B

HACKNEY CARRIAGE/ PRIVATE HIRE DRIVERS LICENCE

CONDITIONS OF LICENCE

HACKNEY CARRIAGE/PRIVATE HIRE DRIVERS LICENCE - CONDITIONS OF LICENCE**General**

- 1.0 Additional information regarding all aspects of driver licensing is available in Shropshire Council's Hackney Carriage and Private Hire Licensing Policy. The Policy must be read in conjunction with the specific conditions set out below. Any legal requirements that apply to the operation of a driver's licence are regarded as if they are conditions of the licence, whether specifically listed or referred to below or in the policy or not. Where reference is made to legal requirements either in the conditions below or in the Council's policy, drivers are advised that such references are not exhaustive and it is the driver's responsibility to ensure they are fully aware of all relevant legal requirements with which they must comply.
- 1.1 All references to 'driver' in the conditions set out below mean a driver who holds a driver's licence issued by the Council in accordance with the Council's Hackney Carriage and Private Hire Licensing Policy and relevant legislation.

Fit and proper person

- 1.2 Throughout the currency of the licence, the driver must continue to be a fit and proper person to hold the licence. In this respect, the driver must have due regard to the relevant provisions of the Council's policy, be aware of the checks that will be undertaken by the Council and act in accordance with the responsibilities that being a fit and proper person would reasonably place on a licensed driver.
- 1.3 In particular, during the currency of a licence, the driver must notify the Council, in writing, within 48 hours, if:
- They receive any warnings, cautions, community resolutions, fixed penalties or driving endorsements (driving convictions)
 - They are arrested (whether or not charged with an offence)
 - They are charged with any criminal offence (includes driving/motoring offences)
 - They are convicted of any criminal offence (includes driving/motoring offences)
 - Allegations are made of their involvement in criminal activity
 - A licence issued by DVLA on behalf of the Office of the Traffic Commissioner, i.e. Passenger Carrying Vehicle (PCV) licence, Public Service Vehicle (PSV), is suspended or revoked or if they receive a written warning
 - A licence issued by another Local Authority is suspended or revoked or if they receive a written warning
- 1.4 It is the responsibility of the driver to notify their insurance company and the vehicle proprietor of any criminal offences relating to driving/motoring offences, fixed penalties or driving endorsements (driving convictions).
- 1.5 It is the responsibility of the driver to notify their private hire operator of any warnings, cautions, fixed penalties or driving endorsements (driving convictions) or criminal convictions/offences listed at 1.3 above.

Criminal record disclosure

- 1.6 Where a licence has been renewed and issued, subject to the receipt of a satisfactory enhanced DBS certificate, the applicant must provide the Council with the DBS certificate within 7 days of the date of receipt. Failure to do so may result in the driver's licence being suspended or revoked.
- 1.7 Drivers must subscribe to the DBS Update Service, within 30 calendar days of the issue date, as stated on the DBS certificate.
- 1.8 Drivers must evidence continuous registration to the DBS Update Service throughout the currency of the licence.

Travelling abroad

- 1.9 Applicants must notify the Council when it is their intention to reside outside of the United Kingdom for three continuous months or more prior to travel.
- 1.10 Applicants must notify the Council as soon as is reasonably practicable where travel plans are extended resulting in an applicant residing outside of the United Kingdom for three continuous months or more.
- 1.11 Applicants who have spent three continuous months or more living outside the United Kingdom, during the period of their licence must produce a certificate of good conduct or equivalent document (at their own cost). This certificate must be issued by the relevant Embassy or High Commission for the country or countries lived in during this period and meet the requirements as set out at 3a.15 of the Policy. It is recognised that some countries will not provide a certificate of good conduct unless the individual has been resident for six months or more. Where a relevant Embassy or High Commission refuse to issue a certificate of good conduct, applicants must provide written confirmation from the Embassy of any refusal to the Licensing Team.

Driver's badge and licence

- 1.12 Drivers must display the 'Vehicle Copy' driver's badge, issued by the Council, in the adhesive holder provided on the inside of the windscreen of the vehicle so as to be plainly visible at all times to passengers.
- 1.13 Loss of a driver's badge must be reported immediately to the Council. The driver must immediately obtain a new driver's badge from the Council for which a fee will be charged. If the original badge is then found, it must be returned to the Council.

Production of records/documents

- 1.14 All original supporting documentation provided upon application must be retained for the duration of the licence period and must be produced, on request, to any authorised officer of the Council or to any police officer.

Insurance

- 1.15 It is the responsibility of a driver with a drivers licence to ensure they are correctly insured to drive the vehicle.

Conduct

1.16 The driver MUST, at all times when working as a hackney carriage and private hire driver:

- Wear their driver's badge around their neck using the council issued lanyard and badge holder ensuring that their photograph and licence details are visible. A driver must demonstrate that they are licensed to undertake hackney carriage or private hire work by willingly showing their driver's badge to passengers, an authorised officer or any police officer.
- Be clean and respectable in their dress and person and maintain a high standard of personal hygiene.
- When driving an executive licensed private hire vehicle be dressed appropriate to the occasion and as a minimum standard shall wear suit, shirt and tie.
- Behave in a civil and orderly manner towards all persons including, but not limited to, other road users, pedestrians, customers, the general public, other licensed operators and drivers of hackney carriage and private hire vehicles, police officers, officers and elected members of the Council.
- Co-operate with any reasonable request made by an authorised officer of the Council or any police officer.
- Ensure that they do not work excessively long hours and take adequate breaks and rest periods.
- Be courteous to passengers, e.g., greeting passengers and opening vehicle doors on behalf of passengers.
- Take all reasonable steps to assist passengers when they are entering or alighting from the vehicle and to convey them, subject to any instructions given by them, to their destination by the shortest practicable route and to ensure their safety.
- Convey a reasonable amount of luggage/other items, e.g., suitcases, shopping bags etc., and afford reasonable assistance in the loading and unloading of any luggage/other items.
- When, having agreed or been hired to attend a specific location at an appointed time with their vehicle, unless delayed/prevented from doing so by some sufficient/reasonable cause, punctually attend at such appointed time and place.
- Show due consideration when driving through residential areas.

1.17 The driver MUST NOT, at any time when working as a hackney carriage and private hire driver:

- Use aggressive, offensive, racist, homophobic, transphobic, abusive, profane or insulting language or behaviour.
- Use or allow to be used a vehicle for illegal or illicit purposes.
- Carry any unessential items in the boot of the vehicle or the passenger seating area which would prevent a wheelchair or mobility aid from being stowed there or prevent a wheelchair user from travelling while seating in their wheelchair.
- Touch a wheelchair or mobility aid or seek to provide physical assistance to a passenger unless the passenger has given them permission to do so.
- Smoke or permit passengers to smoke in their vehicle (this includes electronic cigarettes and vaping).
- Without the express permission of the hirer, eat or drink in the vehicle. (Drivers are only permitted to eat or drink in a vehicle when the vehicle is stationary.)
- Cause or permit sound emitted from any radio/sound reproducing instrument or equipment in the vehicle to be an annoyance/nuisance to any person, whether inside or outside the vehicle.

- Sound their vehicle's horn to alert passengers of the vehicle's arrival.
- Leave the vehicle with the engine running when waiting between journeys.
- Permit persons to be carried in the vehicle unless they have the consent from the person who is actually hiring the vehicle.
- Allow any persons to drive a vehicle unless they are authorised to do so by the proprietor, hold an appropriate licence and are insured to do so.
- Leave their vehicle unattended in any street, rank/stand or public place or venue.
- Obstruct other drivers/vehicles from undertaking their normal hiring and driving activities.

Plying for hire

1.18 The driver **MUST NOT**, at any time when working as a private hire driver:

- Take fares that have not been pre-booked through their licensed private hire operator.
- Make a booking on behalf of a prospective passenger, e.g., via their radio or mobile telephone.

Disabled passengers: Duties of drivers

1.19 The driver **MUST**, at all times when working as a hackney carriage and private hire driver, unless the vehicle being driven is a designated wheelchair accessible vehicle whereby the driver is subject to the requirements of condition 1.23 below:

- Carry the passenger
- If the passenger is in, or has with them a wheelchair, to carry the wheelchair
- If the passenger has with them any mobility aids, to carry the mobility aids
- Take such steps as are reasonable to ensure that the passenger is carried in safety and reasonable comfort
- Provide reasonable levels of mobility assistance, which includes but is not restricted to enabling the passenger to get into or out of the vehicle, to load the passenger's luggage, wheelchair or mobility aids into or out of the vehicle

1.20 The driver **MUST NOT**, at all times when working as a hackney carriage and private hire driver:

- Refuse hires unless it would not be possible or reasonable for the wheelchair or mobility aids to be carried safely in the vehicle.
- Refuse hires unless the driver would not have reasonably known that the passenger was disabled or that the passenger required mobility assistance.

Disabled passengers: assistance to identify and find vehicle

1.21 The driver **MUST**, at all times when working as a hackney carriage and private hire drive, where the driver has been made aware that the passenger requires assistance to identify or find their vehicle:

- Take such steps as are reasonable to assist the passenger to identify and find the vehicle that has been pre-booked.

1.22 The driver **MUST NOT**, at all times when working as a hackney carriage and private hire driver:

- Make, or propose to make, any additional charge for complying with the duty listed in condition 1.19 above.

Disabled passengers in wheelchairs: Duties of drivers of designated wheelchair accessible vehicles

1.23 The driver **MUST**, at all times when working as a hackney carriage and private hire driver and driving a designated wheelchair accessible vehicle:

- Carry the passenger while in the wheelchair
- Ensure that the wheelchair is positioned in such a way so that the wheelchair user is facing towards the front or rear of the vehicle
- Carry the passenger's wheelchair if the wheelchair user chooses to sit in a passenger seat during the journey
- If the passenger has with them any mobility aids, to carry the mobility aids
- Take such steps as are necessary to ensure that the wheelchair user is carried in safe and reasonable comfort
- Provide reasonable levels of mobility assistance to the wheelchair user, which includes but is not restricted to enabling the passenger to get into or out of the vehicle. If the passenger wishes to remain in the wheelchair to enable the passenger to get into and out of the vehicle while in the wheelchair, to load the passenger's luggage or mobility aids into or out of the vehicle and if the passenger does not wish to remain in the wheelchair, to load the wheelchair into or out of the vehicle

1.24 The driver **MUST NOT**, at all times when working as a hackney carriage and private hire driver and driving a designated wheelchair accessible vehicle:

- Make, or propose to make, any additional charge for complying with a duty listed in condition 1.23 above
- Refuse hires from wheelchair users unless it would not be possible or reasonable for the wheelchair or mobility aids to be carried safely in the vehicle

Animals

1.25 When driving a hackney carriage or private hire vehicle, a driver must not carry any animal belonging to them, the proprietor or operator of the vehicle or in their custody whilst fare paying passengers are being conveyed in the vehicle.

1.26 In general the transportation of animals belonging to or in the custody of any fare paying passengers is permitted at the discretion of the vehicle owner/company and if undertaken must be in the rear of the vehicle in the foot well or floor pan of the vehicle.

1.27 However, all types of assistance dogs **MUST** be transported when requested by a passenger (unless the driver holds a medical exemption). Drivers **MUST NOT** impose a charge for carrying assistance dogs. Assistance dogs may be permitted to travel in the front of the vehicle.

Medical requirements

1.28 Drivers must undertake a medical examination and provide a satisfactory medical report and certificate, in accordance with the requirements of the Hackney Carriage and Private Hire Licensing

Policy 2023-2027, every 5 years from the age of 45 or sooner if stipulated by the examining doctor or required by an officer with delegated authority or Licensing and Safety Sub-committee.

- 1.29 Drivers over the age of 65 or who attain the age of 65 during a licensed period must undertake a medical examination and provide a satisfactory medical report and certificate annually or sooner if stipulated by the examining doctor or required by an officer with delegated authority or Licensing and Safety Sub-committee.
- 1.30 Drivers who have a condition identified within the DVLA publication 'Assessing fitness to drive – a guide for medical professionals' as requiring an annual review, are required to provide a satisfactory medical report and certificate on an annual basis.
- 1.31 If a driver's medical circumstances change during the currency of the licence, the driver must inform the Council within 7 days. The Council may require the driver to immediately undertake a further medical examination and provide an approved medical report and certificate confirming the outcome of this examination and the driver's fitness (or otherwise) to continue as a licensed driver.

Medical exemption

- 1.32 Where a driver is exempt on medical grounds from carrying wheelchair bound passengers or assistance dogs, the Council issued medical exemption letter/certificate confirming the exemption must be securely fixed in the front windscreen on the passenger side of the vehicle which does not interfere with the drivers view of the road or on the partition for purpose-built vehicles where a partition is fitted. Failure to display the Council issued medical exemption certificate in the prescribed manner is an offence under the Equality Act 2010.

Change of particulars

- 1.33 The driver must notify the Council, in writing, of any change of particulars which may occur during the currency of their licence, including any change of address, change of phone number, change of email address or change of employer/operator. Any such change must be notified within 7 days. Where a change of address occurs, the driver must also amend the address on their driving licence and produce their driving licence showing the new address to the Council within 7 days of receipt from the issuing body, e.g. DVLA. The photo card licence and/or where applicable the paper counterpart licence must be produced. For those driving licences where the paper counterpart is not issued by the DVLA, the photo card must be provided and the Council will undertake the necessary additional on-line check.

Passengers

- 1.34 The driver must not convey or permit to be conveyed in a private hire vehicle a greater number of passengers than the number prescribed in the vehicle licence.
- 1.35 The driver of the licensed vehicle must only carry one person in the front of the vehicle beside the driver unless the vehicle has been specifically designed to carry more.

Transporting children

- 1.36 Drivers must inform parents/carers that the decision to permit children to travel in the vehicle, without the correctly sized seat restraints (as permitted by relevant legislation) and with the

obvious risks associated with such an action, remains with the parent/carer responsible for the children and not with the driver of the vehicle (See 3a.104 of Shropshire Councils Hackney Carriage and Private Hire Licensing Policy 2023-2027 for details).

Lost property

- 1.37 After fare paying passengers have alighted from the licensed vehicle, the driver must, as soon as is practicable, search the vehicle for any property which may have been left.
- 1.38 Where such property is found and irrespective of the value, the driver must, if it has not been claimed by or on behalf of the passenger (or their representative) who left it within 24 hours, hand it, in the case of a private hire driver, to their operator in accordance with the operators lost property policy.

Parking between bookings

- 1.39 Drivers of private hire vehicles in the Council's area must, as soon as they have dropped passengers at their required destination and unless prevented from doing so by another booking, return to a suitably safe place to park that is not in the vicinity of public houses, nightclubs, restaurants, cafes and similar establishments and that is not in contravention of road traffic legislation, traffic regulation orders and not likely to cause nuisance to others.

Meters

- 1.40 Where taximeters are fitted to vehicles, the driver must not cause the fare recorded thereon to be cancelled or concealed until the hirer has had an opportunity to examine the meter and has paid the fare (or credit has been given).
- 1.41 The driver must ensure:
- The meter is sufficiently illuminated so that when it is in use it is visible to all passenger
 - The meter is used for the whole of any journey, regardless of whether or not a fare is agreed prior to the commencement of the journey
 - The fare or charge is calculated from the point at which the hirer commences the journey and does not exceed that displayed on the meter on the completion of such journey. A journey commences when all passengers and luggage are secured within the vehicle and the vehicle is ready to move off unless otherwise agreed by a private hire operator and the journey fulfilled by a private hire vehicle
 - That the meter must not be left running whilst the driver performs duties under the Equality Act 2010, e.g., when a passenger enters, leaves or secures their wheelchair within the passenger compartment
 - The meter is only brought into action at the commencement of the hirer's journey
 - The correct tariff for that journey is displayed

Fares

- 1.42 The driver must not demand from the hirer a fare in excess of any fare previously agreed between the operator and the hirer, or if the vehicle is fitted with a taximeter and no previous agreement as to the fare, the fare shown on the face of the taximeter.

- 1.43 The driver must, if requested by a fare paying passenger, provide a written receipt for any fare paid.

Identification plates

- 1.44 Drivers must not cause or suffer any vehicle plate to be concealed from public view whilst the vehicle is licensed.

Condition of vehicle

- 1.45 A driver must not drive a licensed vehicle if he has reason to believe that the vehicle is in an unsafe, dangerous or illegal condition. He is advised to inform the operator or proprietor of the vehicle immediately of any defect arising in the vehicle whilst under his control.

Accidents

- 1.46 The driver must, notwithstanding their responsibilities under relevant road traffic legislation, report to the Council and operator or proprietor any accident involving a hackney carriage or private hire vehicle under their control as soon as is practicable and provide photographic evidence of the damage when requested by the Council. However, where the vehicle has suffered accident damage that materially affects the performance or appearance of the vehicle, or the comfort or convenience of fare paying passengers, the driver must notify the Council and operator or proprietor within 72 hours.

Complaints

- 1.47 Where a passenger has cause to complain to a driver about any aspect of the service provided, a driver is encouraged to advise the passenger of their right to make a complaint to the relevant private hire operator and must make it clear to the passenger that they may also refer any complaint direct to the Council.

Safety of children, young persons and adults (including those with care and support needs)

- 1.48 Where a driver has concerns that could relate to the safety of children, young persons and adults (including those with care and support needs), they must report those concerns to either the licensed operator's Designated Person for Safeguarding or, where this is not possible, directly to the relevant authority.

Other legislative requirements

- 1.49 It is the driver's responsibility to make sure they comply with the Road Traffic Act 1988 and all other road traffic legislation, e.g., the Highway Code, parking restrictions and traffic regulation orders, as this is not addressed by the Policy and associated conditions.

APPENDIX C

HACKNEY CARRIAGE LICENCE

CONDITIONS OF LICENCE

HACKNEY CARRIAGE VEHICLE LICENCE - CONDITIONS OF LICENCE

General

- 1.0 Additional information regarding all aspects of hackney carriage licensing is available in the Council's Hackney Carriage and Private Hire Licensing Policy. The Policy must be read in conjunction with the specific conditions set out below. Any legal requirements that apply to the operation of a hackney carriage licence are regarded as if they are conditions of the licence, whether specifically listed or referred to below or in the policy or not. Where reference is made to legal requirements either in the conditions below or in the Council's policy, proprietors are advised that such references are not exhaustive and it is the proprietor's responsibility to ensure they are fully aware of all relevant legal requirements with which they must comply.

Fit and proper person

- 1.1 Throughout the currency of the licence, the proprietor must be a fit and proper person to hold the licence. In this respect, the proprietor must have due regard to the relevant provisions of the Council's policy, be aware of the checks that will be undertaken by the Council and act in accordance with the responsibilities that being a fit and proper person would reasonably place on a proprietor.

Convictions

- 1.2 The proprietor or where the proprietor is a partnership or a company, all partners or directors/company secretaries, as appropriate, during the currency of the licence must, within 48 hours, disclose to the Council, in writing, if:
- They receive any warnings, cautions, community resolutions, fixed penalties or driving endorsements (driving convictions)
 - Are arrested (whether or not charged with an offence)
 - Are charged with any criminal offence (includes driving/motoring offences)
 - Are convicted of any criminal offence (includes driving/motoring offences)
 - Allegations are made of their involvement in criminal activity
 - A licence issued by DVLA on behalf of the Office of the Traffic Commissioner, i.e., Passenger Carrying Vehicle (PCV) licence, Public Service Vehicle (PSV), is suspended or revoked or if they receive a written warning
 - A licence issued by another Local Authority is suspended or revoked or if they receive a written warning

Drivers who may lawfully drive a hackney carriage

- 1.3 The proprietor of a licensed hackney carriage must ensure that only drivers licensed by the Council are permitted to drive the vehicle.

Test requirements

- 1.4 All vehicles must meet the Council's safety and fitness test requirements. Where a vehicle is the subject of any test during the application process or during the currency of any licence and it is

determined that the vehicle is not fit for the purpose of conveying passengers the proprietor must notify the Council as soon as is reasonably practicable, and in any case within 72 hours of the occurrence.

LPG converted vehicles

- 1.5 The proprietor must notify the Council, within 7 days, of any LPG conversion.
- 1.6 The proprietor must provide a copy of the amended V5 registration certificate to the Council within 7 days of the certificate being received.

External vehicle licence plates

- 1.7 The external licence plates (front and rear) identifying the vehicle as a hackney carriage as issued by the Council and required to be exhibited on the vehicle pursuant to Section 47 of the Local Government (Miscellaneous Provisions) Act 1976 must be:
 - Securely fixed to the outside front and rear of the vehicle in a conspicuous position
 - Maintained, kept clean and in such a condition that the information on the plates is clearly visible to the public at all times
 - Displayed at all times and in such a manner as to be easily removable by an authorised officer of the Council or a police officer
- 1.8 **AND** at no time, during the currency of the vehicle licence, is it permitted for the licence plates to be removed from the licensed vehicle.
- 1.9 In the event that a licence plate is lost it is the responsibility of the proprietor of the vehicle to notify the Council within 72 hours and to obtain a replacement plate (at the proprietors cost).
- 1.10 The external licence plates (front and rear) must be returned to the Council within 7 days of revocation or expiry of the vehicle's licence; where the licence is suspended, be returned if required.
- 1.11 Any existing licence plates must be returned to the Council before new licence plates for a vehicle will be issued; this includes transfers.
- 1.12 In addition, a proprietor must not sell, transfer or otherwise dispose of the vehicle plates separately from the vehicle in respect of which they have been issued, nor permit such plates to be sold transferred or otherwise disposed of by anyone else.

External markings

- 1.13 Where applicable, the proprietor must clearly display and maintain on the exterior of the vehicle, in such a position as to be clearly visible at all times a sign confirming that the taxi is wheelchair accessible (the relevant nationally recognised symbol) and caters for the needs of the disabled.

Internal signage

- 1.14 The internal plate must be securely fixed in the front windscreen on the passenger side of the vehicle which does not interfere with the drivers view of the road or on the partition for purpose-built vehicles where a partition is fitted.

- 1.15 Where applicable, the Council issued medical exception notice must be securely fixed in the front windscreen on the passenger side of the vehicle which does not interfere with the drivers view of the road.
- 1.16 In the event that the internal signage is lost it is the responsibility of the proprietor of the vehicle to notify the Council within 72 hours and to obtain a replacement (at the proprietors cost).
- 1.17 The internal signage must be returned to the Council within 7 days of revocation or expiry of the vehicle's licence; where the licence is suspended, be returned if required.

Interior markings

- 1.18 The proprietor must clearly display and maintain inside the vehicle, in such a position as to be clearly visible to passengers inside the vehicle at all times:
- The maximum number of persons licensed to be conveyed therein
 - The hackney carriage licence number
 - Contact details for reporting complaints/compliments to the Council
 - A 'No Smoking' sign

Other requirements

- 1.19 The proprietor MUST at all times:
- Ensure that the vehicle is not used for illegal or illicit purposes
 - Ensure that the vehicle is maintained in a sound mechanical and structural condition
 - Ensure that the vehicle is maintained in a clean and safe condition from both exterior and interior perspectives
 - Ensure that all drivers who drive a wheelchair accessible vehicle have satisfactorily completed training on how to safely restrain a wheelchair user

Use of information on and in relation to hackney carriages

- 1.20 Proprietors must obtain approval from the Council prior to displaying any information, advertisements, images or other material on their hackney carriage.
- 1.21 Materials that are used to display any information, advertisements, images or other material must be of a quality not easily defaced, soiled or detached.
- 1.22 Reflective material must not be used.
- 1.23 Signs used to display any information, advertisements, images or other material must not be illuminated.
- 1.24 Information, advertisements, images or other material may be affixed directly onto the exterior and/or internal body of the vehicle and must be in such a position as not to obscure Council issued plates and all other required signs.
- 1.25 Information, advertisements, images or other material must comply with the relevant requirements as set out in **Appendix L** of the Council's Policy.

- 1.26 Proprietors must not permit any vehicle to be advertised as an 'executive vehicle' or 'executive travel' unless the vehicle is licensed as an executive private hire vehicle by the Council.

Closed circuit television (CCTV)

- 1.27 Proprietors wishing to install closed circuit television (CCTV) in their hackney carriage must notify the Council, in writing, of their intention to do so.
- 1.28 The CCTV system must be installed in accordance with the appropriate legal framework.
- 1.29 Where CCTV is fitted, proprietors must maintain a valid registration with the Information Commissioners Office (ICO) throughout the duration of the licence or until such a time as the CCTV has been removed from the licensed vehicle.
- 1.30 Where a CCTV system is removed from a licensed vehicle, proprietors must notify the Council, in writing, within 7 days.

Trailers

- 1.31 Proprietors must ensure any trailer:
- Is inspected annually with the vehicle to which it relates
 - Has a plate that relates to the towing vehicle(s)
 - Complies with conditions applicable to the use of trailers set out in **Appendix M** of the Councils Policy

Ranks and order of working

- 1.32 Hackney carriage proprietors must take steps to actively encourage drivers on arriving at a rank/stand not already fully occupied by other hackney carriages:
- To park the vehicle immediately behind the vehicle(s) on the stand so as to face in the same direction
 - When the vehicle(s) immediately in front are driven off or move forward must cause the vehicle to be moved forward so as to fill the place previously occupied by the vehicle that has driven off or moved forward
 - Where the rank/stand is fully occupied at the time the driver arrives, the driver must proceed to an alternative rank/stand

Taximeters

- 1.33 When the machinery of the taximeter is in action there must be recorded on the face of the taximeter in figures clearly legible and free from ambiguity, a fare not exceeding the rate of fare which the proprietor or driver is entitled to demand and take for the hire of the vehicle by distance.
- 1.34 The taximeter must be so placed that all the letters and figures on the face thereof shall be at all times plainly visible to any person being conveyed in the vehicle and for that purpose the letters and figures must be capable of being illuminated during any period of hiring.

- 1.35 The taximeter must be set to reflect the current table of fares approved by the Council, or to an alternative table of fares that is in all cases lower than the Council approved table. Where the meter is set to an alternative table that table must be prominently displayed in addition to the approved table. A lesser fare than that shown on the taximeter at the end of a journey may be charged.
- 1.36 Proprietors must ensure that, when hired, a taximeter is used for the whole of any journey commencing within the administrative area of Shropshire Council.
- 1.37 Proprietors must ensure that, when undertaking a pre-booked fare, a taximeter is used for the whole of any journey commencing within the administrative area of Shropshire Council. The driver must not demand from the hirer a fare in excess of the fare shown on the face of the taximeter.

Roof signs

- 1.38 All vehicles are required to display a white roof sign bearing the words TAXI (no other words, letters or numbering are permitted) on the front and rear in uppercase black lettering of a minimum height of 79mm, width 50mm, stroke width 14mm and spacing between lettering of 11mm. The light in the sign must be connected to the meter switch such that the light is switched on when the hackney carriage is available for hire and switched off when the hackney carriage is not available for hire. The sign must be permanently mounted on the roof of the vehicle except in respect of purpose-built taxis.

Change of particulars

- 1.39 The proprietor of a licensed hackney carriage must notify the Council, in writing, of any change of particulars which may occur during the currency of their licence, including any change of address, change of phone number or change of email address, within 7 days of such a change taking place.
- 1.40 A proprietor must notify the Council, in writing, of any change of partners, directors/company secretaries which may occur during the currency of their licence. Any such change must be notified within 7 days.

MOT

- 1.41 The vehicle must have a valid MOT throughout the licence period.
- 1.42 Vehicles must be submitted for an MOT inspection in accordance with the following:
- Vehicles, up to 9 years from date of first registration, must be submitted for an MOT inspection at 6-monthly intervals.
 - Vehicles 9 years of age or older from date of first registration, in addition to the MOT certificate submitted with an application, must have two additional MOT tests per year; tests being spaced evenly throughout the year at four monthly intervals.
- 1.43 A copy of the MOT certificate must be submitted to the Licensing Team within 10 working days of the date of issue from the MOT testing centre.

MOT failures and advisories

- 1.44 Where a vehicle has failed an MOT under the category dangerous (do not drive until repaired) defects, the proprietor of a licensed hackney carriage must ensure that the vehicle is not used as a hackney carriage until the repairs have been undertaken and a new MOT pass certificate issued.
- 1.45 Where a vehicle fails an MOT under the category major (repair immediately) defects, the proprietor of a licensed hackney carriage must ensure that the vehicle is not used as a hackney carriage until the repairs have been undertaken and a new MOT pass certificate issued.
- 1.46 The proprietor of a licensed hackney carriage must, when requested by the Council, rectify any items listed under minor or advisory information on an MOT certificate and provide evidence that the work has been completed to the Council within a specified time.

Insurance

- 1.47 Satisfactory evidence must be produced that there is in force, for the use of the vehicle, a policy of insurance covering the carriage of passengers for hire or reward or such security as complies with the requirements of Part VI of the Road Traffic Act 1988.
- 1.48 The proprietor must ensure that at all times a list is maintained of all licensed drivers authorised under the policy to drive the vehicle and must make such a list available to an authorised officer of the Council or a police officer at all reasonable times, when so required.
- 1.49 Proprietors must ensure that where a vehicle is insured by a proprietor and the proprietor allows another licensed Shropshire Council driver to drive their vehicle, or the vehicle is covered under a fleet insurance policy, drivers are aware of the content of the insurance policy, including its limitations and exclusions. The proprietor must keep a record, signed by the driver, when this has been completed.

Smoking

- 1.50 The proprietor of a hackney carriage must not permit the driver and passengers to smoke in the licensed vehicle (this includes electronic cigarettes and vaping).

Vehicle Excise Duty (Road Tax)

- 1.51 The vehicle must have valid Road Tax throughout the currency of the licence.

Fare card

- 1.52 A copy of the Council's current table of fares must be kept, maintained and clearly displayed in the vehicle at all times in the location provided by the manufacturers of the vehicle or in accordance with any instructions given by an authorised officer.

Lost Property

- 1.53 Proprietors must keep and maintain a record of all lost property detailing the date and time, the item found, the vehicle details and action taken to return the item to the rightful owner, to the police or disposal.

- 1.54 Where proprietors have received property belonging to passengers or where a proprietor finds such property themselves, a proprietor must take the necessary steps to establish the identity of the owner of the property. If, however, the proprietor is not able to establish the identity of the owner, any property of high value or that contains a serial number should be handed into the police.

Alterations to vehicles

- 1.55 No material alteration or change in the mechanical or structural specification, design, condition or appearance of the vehicle is permitted without the prior approval of the Council, this includes but is not restricted to bull bars, running boards, side steps, side bars, LPG conversions and other similar alterations and changes.

Damage to vehicles

- 1.56 Notification must be given by the proprietor to the Council as soon as reasonably practicable on the Councils accident report form and in any case within 72 hours of the occurrence of any accident/damage to the vehicle that materially affects the safety, performance or appearance of the vehicle, or the comfort or convenience of persons carried therein and provide photographic evidence of the damage when requested by the Council.
- 1.57 Where a proprietor has notified the Council that a licensed vehicle has sustained structural damage from a road traffic accident resulting in a DVLA classification under Category S – Structural damage (vehicle that has sustained damage after 1 October 2017) or Category C (vehicle has sustained damage, rendering it beyond economical repair, prior to 1 October 2017), the vehicle must be submitted for a voluntary IVA inspection and a valid IVA certificate provided to the Licensing Team before the vehicle is permitted to be used as a hackney carriage.

Production of records/documents

- 1.58 All original supporting documentation provided upon application must be retained for the duration of the licence period and must be produced, on request, to any authorised officer of the Council or to any police officer.

Inspection/examination

- 1.59 The proprietor must permit any authorised officer of the Council or any police officer, at all reasonable times, to inspect and examine the vehicle and to request driver identification and insurance details. A drivers badge must be produced to an officer of the Council or any police officer during the inspection/examination. A drivers identification, certificate of insurance and MOT must be produced either during the inspection/examination to any authorised officer of the Council or any police officer or within 7 days to any authorised officer of the Council or any police officer.

APPENDIX D

STANDARD PRIVATE HIRE VEHICLE LICENCE

CONDITIONS OF LICENCE

STANDARD PRIVATE HIRE VEHICLE LICENCE - CONDITIONS OF LICENCE**General**

- 1.0 Additional information regarding all aspects of private hire licensing is available in the Council's Hackney Carriage and Private Hire Licensing Policy and this must be read in conjunction with the specific conditions set out below. Any legal requirements that apply to the operation of a private hire licence are regarded as if they are conditions of the licence, whether specifically listed below or in the policy or not. Where reference is made to legal requirements either in the conditions below or in the Council's policy, proprietors are advised that such references are not exhaustive and it is the proprietor's responsibility to ensure they are fully aware of all relevant legal requirements with which they must comply.

Fit and proper person

- 1.1 Throughout the currency of the licence, the proprietor must be a fit and proper person to hold the licence. In this respect, the proprietor must have due regard to the relevant provisions of the Council's policy, be aware of the checks that will be undertaken by the Council and act in accordance with the responsibilities that being a fit and proper person would reasonably place on a proprietor.

Convictions

- 1.2 The proprietor or where the proprietor is a partnership or a company, all partners or directors/company secretaries, as appropriate, during the currency of the licence must, within 48 hours, disclose to the Council, in writing, if:
- They receive any warnings, cautions, community resolutions, fixed penalties or driving endorsements (driving convictions)
 - Are arrested (whether or not charged with an offence)
 - Are charged with any criminal offence (includes driving/motoring offences)
 - Are convicted of any criminal offence (includes driving/motoring offences)
 - Allegations are made of their involvement in criminal activity
 - A licence issued by DVLA on behalf of the Office of the Traffic Commissioner, i.e., Passenger Carrying Vehicle (PCV) licence, Public Service Vehicle (PSV), is suspended or revoked or if they receive a written warning
 - A licence issued by another Local Authority is suspended or revoked or if they receive a written warning

Drivers who may lawfully drive a private hire vehicle

- 1.3 The proprietor of a licensed private hire vehicle must ensure that only drivers licensed by the Council are permitted to drive the vehicle.

Test requirements

- 1.4 All vehicles must meet the Council's safety and fitness test requirements. Where a vehicle is the subject of any test during the application process or during the currency of any licence and it is

determined that the vehicle is not fit for the purpose of conveying passengers the proprietor must notify the Council as soon as is reasonably practicable, and in any case within 72 hours of the occurrence.

LPG converted vehicles

- 1.5 The proprietor must notify the Council, within 7 days, of any LPG conversion.
- 1.6 The proprietor must provide a copy of the amended V5 registration certificate to the Council within 7 days of the certificate being received.

External vehicle licence plates

- 1.7 The external licence plates (front and rear) identifying the vehicle as a private hire vehicle as issued by the Council and required to be exhibited on the vehicle pursuant to Section 48 of the Local Government (Miscellaneous Provisions) Act 1976 must be:
 - Securely fixed to the outside front and rear of the vehicle in a conspicuous position
 - Maintained, kept clean and in such a condition that the information on the plates is clearly visible to the public at all times
 - Displayed at all times and in such a manner as to be easily removable by an authorised officer of the Council or a police officer
- 1.8 **AND** at no time, during the currency of the vehicle licence, is it permitted for the licence plates to be removed from the licensed vehicle.
- 1.9 In the event that a licence plate is lost it is the responsibility of the proprietor of the vehicle to notify the Council within 72 hours and to obtain a replacement plate (at the proprietors cost).
- 1.10 The external licence plates (front and rear) must be returned to the Council within 7 days of revocation or expiry of the vehicle's licence; where the licence is suspended, be returned if required.
- 1.11 Any existing licence plates must be returned to the Council before new licence plates for a vehicle will be issued; this includes transfers.
- 1.12 In addition, a proprietor must not sell, transfer or otherwise dispose of the vehicle plates separately from the vehicle in respect of which they have been issued, nor permit such plates to be sold transferred or otherwise disposed of by anyone else.

External markings

- 1.13 Where applicable, the proprietor must clearly display and maintain on the exterior of the vehicle, in such a position as to be clearly visible at all times, a sign confirming that the private hire vehicle is wheelchair accessible (the relevant nationally recognised symbol) and caters for the needs of the disabled.

Signs

- 1.14 Private hire vehicles must not display a roof sign.

- 1.15 All vehicles must display Council issued signs (side plates) on the upper portion of the front driver door and the front passenger door of the vehicle using the adhesive backed signs provided. The signs must be kept intact, clean and firmly attached to the vehicle doors as described above. The use of magnetic panels is prohibited. The removal of the signs is prohibited whilst the vehicle is licensed by Shropshire Council. In the event that a side plate is lost it is the responsibility of the proprietor of the vehicle to notify the Council within 72 hours and to obtain a replacement side plate (at the proprietors cost).
- 1.16 The side plates must be returned to the Council within 7 days of revocation or expiry of the vehicle's licence; where the licence is suspended, be returned if required.

Internal signage

- 1.17 The internal plate must be securely fixed in the front windscreen on the passenger side of the vehicle which does not interfere with the drivers view of the road or on the partition for purpose-built vehicles where a partition is fitted.
- 1.18 Where applicable, the Council issued medical exception notice must be securely fixed in the front windscreen on the passenger side of the vehicle which does not interfere with the drivers view of the road.
- 1.19 In the event that the internal signage is lost it is the responsibility of the proprietor of the vehicle to notify the Council within 72 hours and to obtain a replacement (at the proprietors cost).
- 1.20 The internal signage must be returned to the Council within 7 days of revocation or expiry of the vehicle's licence; where the licence is suspended, be returned if required.

Interior markings

- 1.21 The proprietor must clearly mark and maintain inside the vehicle, in such a position as to be clearly visible to passengers inside the vehicle at all times:
- The maximum number of persons licensed to be conveyed therein
 - The private hire vehicle licence number
 - Contact details for reporting complaints/compliments to the Council
 - A 'No Smoking' sign
- 1.22 In addition, if a proprietor wishes to operate a pre-payment system, signs indicating the period and under what circumstances this is applicable are permitted, e.g., pre-payment required between the hours of 1900 to 0700. This does not mean such signs or pre-payment between these hours is compulsory; the condition simply permits a sign to be displayed should a proprietor wish to operate a pre-payment system.

Other requirements

- 1.23 The proprietor MUST at all times:
- Ensure that the vehicle is not used for illegal or illicit purposes
 - Ensure that the vehicle is maintained in a sound mechanical and structural condition
 - Ensure that the vehicle is maintained in a clean and safe condition from both exterior and interior perspectives

- Ensure that all drivers who drive a wheelchair accessible vehicle have satisfactorily completed training on how to safely restrain a wheelchair user

Use of information on and in relation to private hire vehicles

- 1.24 Proprietors must obtain approval from the Council prior to displaying any information, advertisements, images or other material on their private hire vehicle.
- 1.25 Materials that are used to display any information, advertisements, images or other material must be of a quality not easily defaced, soiled or detached.
- 1.26 Reflective material must not be used.
- 1.27 Signs used to display any information, advertisements, images or other material must not be illuminated.
- 1.28 Information, advertisements, images or other material may be affixed directly onto the exterior and/or internal body of the vehicle and must be in such a position as not to obscure Council issued plates and all other required signs.
- 1.29 Information, advertisements, images or other material must comply with the relevant requirements as set out in **Appendix L** of the Council's Policy.
- 1.30 Private hire vehicles are prohibited from displaying the words 'taxi' or 'cab' in the singular or plural or the word 'hire' unless the word 'hire' forms part of the relevant company name or any word or similar meaning (e.g., 'kab') or appearance to any of these words, whether alone or as part of another word.
- 1.31 Proprietors must not permit any vehicle to be advertised as an 'executive vehicle' or 'executive travel' unless the vehicle is licensed as an executive private hire vehicle by the Council.

Closed circuit television (CCTV)

- 1.32 Proprietors wishing to install closed circuit television (CCTV) in their private hire vehicle, must notify the Council, in writing, of their intention to do so.
- 1.33 The CCTV system must be installed in accordance with the appropriate legal framework.
- 1.34 Where CCTV is fitted, proprietors must maintain a valid registration with the Information Commissioners Office (ICO) throughout the duration of the licence or until such a time as the CCTV has been removed from the licensed vehicle.
- 1.35 Where a CCTV system is removed from a licensed vehicle, proprietors must notify the Council, in writing, within 7 days.

Trailers

- 1.36 Proprietors must ensure any trailer:
- Is inspected annually with the vehicle to which it relates
 - Has a plate that relates to the towing vehicle(s)

- Complies with conditions applicable to the use of trailers set out in **Appendix M** of the Councils Policy

Meters

1.37 Whilst the fitting of meters is not mandatory in private hire vehicles, if meters are fitted, then the following conditions apply:

- When the machinery of the meter is in action there must be recorded on the face of the meter in figures clearly legible and free from ambiguity, a fare not exceeding the rate of fare which the proprietor or driver is entitled to demand and take for the hire of the vehicle by distance.
- The meter must be so placed that all the letters and figures on the face thereof shall be at all times plainly visible to any person being conveyed in the vehicle and for that purpose the letters and figures must be capable of being illuminated during any period of hiring.
- The meter must be set to reflect the current private hire operator's tariff.
- Where there is a change to the private hire operator's tariff the meter must be re-calibrated to the new tariff and the meter checked against a measured distance before the vehicle can recommence private hire work.
- The proprietor of the vehicle must provide a valid certificate/report of compliance to the Council within 72 hours of the new private hire operator's tariff coming into effect, confirming the date the meter was calibrated to the new tariff.

Change of particulars

1.38 The proprietor of a licensed private hire vehicle must notify the Council, in writing, of any change of particulars which may occur during the currency of their licence, including any change of address, change of phone number or change of email address, within 7 days of such a change taking place.

1.39 A proprietor must notify the Council, in writing, of any change of partners, directors/company secretaries which may occur during the currency of their licence. Any such change must be notified within 7 days.

MOT

1.40 The vehicle must have a valid MOT throughout the licence period.

1.41 Vehicles must be submitted for an MOT inspection in accordance with the following:

- Vehicles, up to 9 years from date of first registration, must be submitted for an MOT inspection at 6-monthly intervals.
- Vehicles 9 years of age or older from date of first registration, in addition to the MOT certificate submitted with an application, must have two additional MOT tests per year; tests being spaced evenly throughout the year at four monthly intervals.

1.42 A copy of the MOT certificate must be submitted to the Licensing Team within 10 working days of the date of issue from the MOT testing centre.

MOT failures and advisories

- 1.43 Where a vehicle has failed an MOT under the category dangerous (do not drive until repaired) defects, the proprietor of a licensed private hire vehicle must ensure that the vehicle is not used as a private hire vehicle until the repairs have been undertaken and a new MOT pass certificate issued.
- 1.44 Where a vehicle fails an MOT under the category major (repair immediately) defects, the proprietor of a licensed private hire vehicle must ensure that the vehicle is not used as a private hire vehicle until the repairs have been undertaken and a new MOT pass certificate issued.
- 1.45 The proprietor of a licensed private hire vehicle must, when requested by the Council, rectify any items listed under minor or advisory information on an MOT certificate and provide evidence that the work has been completed to the Council within a specified time.

Insurance

- 1.46 Satisfactory evidence must be produced that there is in force, for the use of the vehicle, a policy of insurance covering the carriage of passengers for hire or reward by pre-booking only or such security as complies with the requirements of Part VI of the Road Traffic Act 1988.
- 1.47 The proprietor must ensure that at all times a list is maintained of all licensed drivers authorised under the policy to drive the vehicle and must make such a list available to an authorised officer of the Council or a police officer at all reasonable times, when so required.
- 1.48 Proprietors must ensure that where a vehicle is insured by a proprietor and the proprietor allows another licensed Shropshire Council driver to drive their vehicle, or the vehicle is covered under a fleet insurance policy, drivers are aware of the content of the policy, including its limitations and exclusions. The proprietor must keep a record, signed by the driver, when this has been completed.

Smoking

- 1.49 The proprietor of a private hire vehicle must not permit the driver and passengers to smoke in the licensed vehicle (this includes electronic cigarettes).

Vehicle Excise Duty (Road Tax)

- 1.50 The vehicle must have valid Road Tax throughout the currency of the licence.

Alterations to vehicles

- 1.51 No material alteration or change in the mechanical or structural specification, design, condition or appearance of the vehicle is permitted without the prior approval of the Council, this includes but is not restricted to bull bars, running boards, side steps, side bars, LPG conversions and other similar alterations and changes.

Damage to vehicles

- 1.52 Notification must be given by the proprietor to the Council as soon as reasonably practicable on the Councils accident report form and in any case within 72 hours of the occurrence of any

accident/damage to the vehicle that materially affects the safety, performance or appearance of the vehicle, or the comfort or convenience of persons carried therein and provide photographic evidence of the damage when requested by the Council.

- 1.53 Where a proprietor has notified the Council that a licensed vehicle has sustained structural damage from a road traffic accident resulting in a DVLA classification under Category S – Structural damage (vehicle that has sustained damage after 1 October 2017) or Category C (vehicle has sustained damage, rendering it beyond economical repair, prior to 1 October 2017), the vehicle must be submitted for a voluntary IVA inspection and a valid IVA certificate provided to the Licensing Team before the vehicle is permitted to be used as a private hire vehicle.

Production of records/documents

- 1.54 All original supporting documentation provided upon application must be retained for the duration of the licence period and must be produced, on request, to any authorised officer of the Council or to any police officer.

Inspection/examination

- 1.55 The proprietor must permit any authorised officer of the Council or any police officer, at all reasonable times, to inspect and examine the vehicle and to request driver identification and insurance details. A drivers badge must be produced to an officer of the Council or any police officer during the inspection/examination. A drivers identification, certificate of insurance and MOT must be produced either during the inspection/examination to any authorised officer of the Council or any police officer or within 7 days to any authorised officer of the Council or any police officer.

APPENDIX E

EXECUTIVE PRIVATE HIRE VEHICLE LICENCE

CONDITIONS OF LICENCE

EXECUTIVE PRIVATE HIRE VEHICLE LICENCE - CONDITIONS OF LICENCE**General**

- 1.0 Additional information regarding all aspects of private hire licensing is available in the Council's Hackney Carriage and Private Hire Licensing Policy and this must be read in conjunction with the specific conditions set out below. Any legal requirements that apply to the operation of a private hire licence are regarded as if they are conditions of the licence, whether specifically listed below or in the policy or not. Where reference is made to legal requirements either in the conditions below or in the Council's policy, proprietors are advised that such references are not exhaustive and it is the proprietor's responsibility to ensure they are fully aware of all relevant legal requirements with which they must comply.

Fit and proper person

- 1.1 Throughout the currency of the licence, the proprietor must be a fit and proper person to hold the licence. In this respect, the proprietor must have due regard to the relevant provisions of the Council's policy, be aware of the checks that will be undertaken by the Council and act in accordance with the responsibilities that being a fit and proper person would reasonably place on a proprietor.

Convictions

- 1.2 The proprietor or where the proprietor is a partnership or a company, all partners or directors/company secretaries, as appropriate, during the currency of the licence must, within 48 hours, disclose to the Council, in writing, if:
- They receive any warnings, cautions, community resolutions, fixed penalties or driving endorsements (driving convictions)
 - Are arrested (whether or not charged with an offence)
 - Are charged with any criminal offence (includes driving/motoring offences)
 - Are convicted of any criminal offence (includes driving/motoring offences)
 - Allegations are made of their involvement in criminal activity
 - A licence issued by DVLA on behalf of the Office of the Traffic Commissioner, i.e., Passenger Carrying Vehicle (PCV) licence, Public Service Vehicle (PSV), is suspended or revoked or if they receive a written warning
 - A licence issued by another Local Authority is suspended or revoked or if they receive a written warning

Drivers who may lawfully drive an executive private hire vehicle

- 1.3 The proprietor of a licensed executive private hire vehicle must ensure that only drivers licensed by the Council are permitted to drive the vehicle.

Test requirements

- 1.4 All vehicles must meet the Council's safety and fitness test requirements. Where a vehicle is the subject of any test during the application process or during the currency of any licence and it is

determined that the vehicle is not fit for the purpose of conveying passengers the proprietor must notify the Council as soon as is reasonably practicable, and in any case within 72 hours of the occurrence.

LPG converted vehicles

- 1.5 The proprietor must notify the Council, within 7 days, of any LPG conversion.
- 1.6 The proprietor must provide a copy of the amended V5 registration certificate to the Council within 7 days of the certificate being received.

External vehicle licence plates

- 1.7 The external licence plate identifying the vehicle as an executive private hire vehicle as issued by the Council and required to be exhibited on the vehicle pursuant to Section 48 of the Local Government (Miscellaneous Provisions) Act 1976 must be:
 - Securely fixed to the outside rear of the vehicle in a conspicuous position (the requirement for a front plate does not apply to executive vehicles)
 - Maintained, kept clean and in such a condition that the information on the plates is clearly visible to the public at all times
 - Displayed at all times and in such a manner as to be easily removable by an authorised officer of the Council or a police officer (except during any period that a vehicle is used for carrying passengers for hire or reward under a contract, where the contract specifically requires no plates to be displayed, and where the hire of the vehicle is for a period of not less than 24 hours. During the period where the plates are not displayed they must be retained in the vehicle and made available for inspection by an authorised officer of the Council or a police officer when requested)
- 1.8 In the event that a licence plate is lost it is the responsibility of the proprietor of the vehicle to notify the Council within 72 hours and to obtain a replacement plate (at the proprietors cost).
- 1.9 The external licence plate must be returned to the Council within 7 days of revocation or expiry of the vehicle's licence; where the licence is suspended, be returned if required.
- 1.10 Any existing licence plates must be returned to the Council before new licence plates for a vehicle will be issued; this includes transfers.
- 1.11 In addition, a proprietor must not sell, transfer or otherwise dispose of the vehicle plates separately from the vehicle in respect of which they have been issued, nor permit such plates to be sold transferred or otherwise disposed of by anyone else.

Signs

- 1.12 Executive private hire vehicles must not display a roof sign.
- 1.13 Executive private hire vehicles must not display any company advertising, information, images or other material.

Internal signage

- 1.14 The internal executive licence signage must be securely fixed in the front windscreen on the passenger side of the vehicle which does not interfere with the drivers view of the road or on the partition for purpose-built vehicles where a partition is fitted.
- 1.15 Where applicable, the Council issued medical exception notice must be securely fixed in the front windscreen on the passenger side of the vehicle which does not interfere with the drivers view of the road.
- 1.16 In the event that the internal signage is lost it is the responsibility of the proprietor of the vehicle to notify the Council within 72 hours and to obtain a replacement (at the proprietors cost).
- 1.17 The internal signage must be returned to the Council within 7 days of revocation or expiry of the vehicle's licence; where the licence is suspended, be returned if required.

Interior markings

- 1.18 The proprietor must clearly display and maintain inside the vehicle, in such a position as to be clearly visible to passengers inside the vehicle at all times;
- The maximum number of persons licensed to be conveyed therein
 - The private hire vehicle licence number
 - Contact details for reporting complaints/compliments to the Council
 - A 'No Smoking' sign

Other requirements

- 1.19 The proprietor MUST at all times:
- Ensure that the vehicle is not used for illegal or illicit purposes
 - Ensure that the vehicle is maintained in a sound mechanical and structural condition
 - Ensure that the vehicle is maintained in a clean and safe condition from both exterior and interior perspectives
 - Ensure that all drivers who drive a wheelchair accessible vehicle have satisfactorily completed training on how to safely restrain a wheelchair user

Use of information on and in relation to executive private hire vehicles

- 1.20 Displaying information, advertisements, images or other material in or on an executive private hire vehicle is prohibited.

Closed circuit television (CCTV)

- 1.21 Proprietors wishing to install closed circuit television (CCTV) in their executive private hire vehicle, must notify the Council, in writing, of their intention to do so.
- 1.22 The CCTV system must be installed in accordance with the appropriate legal framework.

- 1.23 Where CCTV is fitted, proprietors must maintain a valid registration with the Information Commissioners Office (ICO) throughout the duration of the licence or until such a time as the CCTV has been removed from the licensed vehicle.
- 1.24 Where a CCTV system is removed from a licensed vehicle, proprietors must notify the Council, in writing, within 7 days.

Trailers

- 1.25 Proprietors must ensure any trailer:
- Is inspected annually with the vehicle to which it relates
 - Has a plate that relates to the towing vehicle(s)
 - Complies with conditions applicable to the use of trailers set out in **Appendix M** of the Councils policy

Change of particulars

- 1.26 The proprietor of a licensed executive private hire vehicle must notify the Council, in writing, of any change of particulars which may occur during the currency of their licence, including any change of address, change of phone number or change of email address, within 7 days of such a change taking place.
- 1.27 A proprietor must notify the Council, in writing, of any change of partners, directors/company secretaries which may occur during the currency of their licence. Any such change must be notified within 7 days.
- 1.28 Where there is a change to a private hire operator of an executive private hire vehicle, written confirmation from the new private hire operator that the vehicle will only undertake executive work must be received by the Council within 7 days of such change taking place.

MOT

- 1.29 The vehicle must have a valid MOT throughout the licence period.
- 1.30 Vehicles must be submitted for an MOT inspection in accordance with the following:
- Vehicles, up to 9 years from date of first registration, must be submitted for an MOT inspection at 6-monthly intervals.
 - Vehicles 9 years of age or older from date of first registration, in addition to the MOT certificate submitted with an application, must have two additional MOT tests per year; tests being spaced evenly throughout the year at four monthly intervals.
- 1.31 A copy of the MOT certificate must be submitted to the Licensing Team within 10 working days of the date of issue from the MOT testing centre.

MOT failures and advisories

- 1.32 Where a vehicle has failed an MOT under the category dangerous (do not drive until repaired) defects, the proprietor of a licensed executive private hire vehicle must ensure that the vehicle is

not used as an executive private hire vehicle until the repairs have been undertaken and a new MOT pass certificate issued.

- 1.33 Where a vehicle fails an MOT under the category major (repair immediately) defects, the proprietor of a licensed executive private hire vehicle must ensure that the vehicle is not used as an executive private hire vehicle until the repairs have been undertaken and a new MOT pass certificate issued.
- 1.34 The proprietor of a licensed executive private hire vehicle must, when requested by the Council, rectify any items listed under minor or advisory information on an MOT certificate and provide evidence that the work has been completed to the Council within a specified time.

Insurance

- 1.35 Satisfactory evidence must be produced that there is in force, for the use of the vehicle, a policy of insurance covering the carriage of passengers for hire or reward by pre-booking only or such security as complies with the requirements of Part VI of the Road Traffic Act 1988.
- 1.36 The proprietor must ensure that at all times a list is maintained of all licensed drivers authorised under the policy to drive the vehicle and must make such a list available to an authorised officer of the Council or a police officer at all reasonable times, when so required.
- 1.37 Proprietors must ensure that where a vehicle is insured by a proprietor and the proprietor allows another licensed Shropshire Council driver to drive their vehicle, or the vehicle is covered under a fleet insurance policy, drivers are aware of the content of the policy, including its limitations and exclusions. The proprietor must keep a record, signed by the driver, when this has been completed.

Smoking

- 1.38 The proprietor of a private hire vehicle must not permit the driver and passengers to smoke in the licensed vehicle (this includes electronic cigarettes).

Vehicle Excise Duty (Road Tax)

- 1.39 The vehicle must have valid Road Tax throughout the currency of the licence.

Alterations to vehicles

- 1.40 No material alteration or change in the mechanical or structural specification, design, condition or appearance of the vehicle is permitted without the prior approval of the Council, this includes but is not restricted to bull bars, running boards, side steps, side bars, LPG conversions and other similar alterations and changes.

Damage to vehicles

- 1.41 Notification must be given by the proprietor to the Council as soon as reasonably practicable on the Councils accident report form and in any case within 72 hours of the occurrence of any accident/damage to the vehicle that materially affects the safety, performance or appearance of the vehicle, or the comfort or convenience of persons carried therein and provide photographic evidence of the damage when requested by the Council.

- 1.42 Where a proprietor has notified the Council that a licensed vehicle has sustained structural damage from a road traffic accident resulting in a DVLA classification under Category S – Structural damage (vehicle that has sustained damage after 1 October 2017) or Category C (vehicle has sustained damage, rendering it beyond economical repair, prior to 1 October 2017), the vehicle must be submitted for a voluntary IVA inspection and a valid IVA certificate provided to the Licensing Team before the vehicle is permitted to be used as an executive private hire vehicle.

Production of records/documents

- 1.43 All original supporting documentation provided upon application must be retained for the duration of the licence period and must be produced, on request, to any authorised officer of the Council or to any police officer.

Inspection/examination

- 1.44 The proprietor must permit any authorised officer of the Council or any police officer, at all reasonable times, to inspect and examine the vehicle and to request driver identification and insurance details. A drivers badge must be produced to an officer of the Council or any police officer during the inspection/examination. A drivers identification, certificate of insurance and MOT must be produced either during the inspection/examination to any authorised officer of the Council or any police officer or within 7 days to any authorised officer of the Council or any police officer.

APPENDIX F

NOVELTY PRIVATE HIRE VEHICLE LICENCE

CONDITIONS OF LICENCE

NOVELTY PRIVATE HIRE VEHICLE LICENCE - CONDITIONS OF LICENCE**General**

- 1.0 Additional information regarding all aspects of private hire licensing is available in the Council's Hackney Carriage and Private Hire Licensing Policy and this must be read in conjunction with the specific conditions set out below. Any legal requirements that apply to the operation of a private hire licence are regarded as if they are conditions of the licence, whether specifically listed below or in the policy or not. Where reference is made to legal requirements either in the conditions below or in the Council's policy, proprietors are advised that such references are not exhaustive and it is the proprietor's responsibility to ensure they are fully aware of all relevant legal requirements with which they must comply.

Fit and proper person

- 1.1 Throughout the currency of the licence, the proprietor must be a fit and proper person to hold the licence. In this respect, the proprietor must have due regard to the relevant provisions of the Council's policy, be aware of the checks that will be undertaken by the Council and act in accordance with the responsibilities that being a fit and proper person would reasonably place on a proprietor.

Convictions

- 1.2 The proprietor or where the proprietor is a partnership or a company, all partners or directors/company secretaries, as appropriate, during the currency of the licence must, within 48 hours, disclose to the Council, in writing, if:
- They receive any warnings, cautions, community resolutions, fixed penalties or driving endorsements (driving convictions)
 - Are arrested (whether or not charged with an offence)
 - Are charged with any criminal offence (includes driving/motoring offences)
 - Are convicted of any criminal offence (includes driving/motoring offences)
 - Allegations are made of their involvement in criminal activity
 - A licence issued by DVLA on behalf of the Office of the Traffic Commissioner, i.e., Passenger Carrying Vehicle (PCV) licence, Public Service Vehicle (PSV), is suspended or revoked or if they receive a written warning
 - A licence issued by another Local Authority is suspended or revoked or if they receive a written warning

Drivers who may lawfully drive a private hire vehicle

- 1.3 The proprietor of a licensed private hire vehicle must ensure that only drivers licensed by the Council are permitted to drive the vehicle.

Test requirements

- 1.4 All vehicles must meet the Council's safety and fitness test requirements. Where a vehicle is the subject of any test during the application process or during the currency of any licence and it is

determined that the vehicle is not fit for the purpose of conveying passengers the proprietor must notify the Council as soon as is reasonably practicable, and in any case within 72 hours of the occurrence.

LPG converted vehicles

- 1.5 The proprietor must notify the Council, within 7 days, of any LPG conversion.
- 1.6 The proprietor must provide a copy of the amended V5 registration certificate to the Council within 7 days of the certificate being received.

External vehicle licence plates

- 1.7 The external vehicle licence plate identifying the vehicle as a novelty private hire vehicle as issued by the Council and required to be exhibited on the vehicle pursuant to Section 48 of the Local Government (Miscellaneous Provisions) Act 1976 must be:
 - Securely fixed to the outside rear of the vehicle in a conspicuous position (the requirement for a front plate does not apply to novelty private hire vehicles)
 - Maintained, kept clean and in such a condition that the information on the plates is clearly visible to the public at all times
 - Displayed at all times and in such a manner as to be easily removable by an authorised officer of the Council or a police officer
- 1.8 AND at no time, during the currency of the vehicle licence, is it permitted for the licence plates to be removed from the licensed vehicle.
- 1.9 In the event that a licence plate is lost it is the responsibility of the proprietor of the vehicle to notify the Council within 72 hours and to obtain a replacement plate (at the proprietors cost).
- 1.10 The external licence plate must be returned to the Council within 7 days of revocation or expiry of the vehicle's licence; where the licence is suspended, be returned if required.
- 1.11 Any existing licence plates must be returned to the Council before new licence plates for a vehicle will be issued; this includes transfers.
- 1.12 In addition, a proprietor must not sell, transfer or otherwise dispose of the vehicle plates separately from the vehicle in respect of which they have been issued, nor permit such plates to be sold transferred or otherwise disposed of by anyone else.

Signs

- 1.13 Novelty private hire vehicles must not display a roof sign.

Internal signage

- 1.14 The internal novelty private hire vehicle licence signage must be securely fixed in the front windscreen on the passenger side of the vehicle which does not interfere with the drivers view of the road or on the partition for purpose-built vehicles where a partition is fitted.

- 1.15 Where applicable, the Council issued medical exception notice must be securely fixed in the front windscreen on the passenger side of the vehicle which does not interfere with the drivers view of the road.
- 1.16 In the event that the internal signage is lost it is the responsibility of the proprietor of the vehicle to notify the Council within 72 hours and to obtain a replacement (at the proprietors cost).
- 1.17 The internal signage must be returned to the Council within 7 days of revocation or expiry of the vehicle's licence; where the licence is suspended, be returned if required.

Interior markings

- 1.18 The proprietor must clearly display and maintain inside the vehicle, in such a position as to be clearly visible to passengers inside the vehicle at all times:
- The maximum number of persons licensed to be conveyed therein
 - The private hire vehicle licence number
 - Contact details for reporting complaints/compliments to the Council
 - A 'No Smoking' sign
- 1.19 In addition, if a proprietor wishes to operate a pre-payment system, signs indicating the period and under what circumstances this is applicable are permitted, e.g., pre-payment required between the hours of 1900 to 0700. This does not mean such signs or pre-payment between these hours is compulsory; the condition simply permits a sign to be displayed should a proprietor wish to operate a pre-payment system.

Other requirements

- 1.20 The proprietor MUST at all times:
- Ensure that the vehicle is not used for illegal or illicit purposes
 - Ensure that the vehicle is maintained in a sound mechanical and structural condition
 - Ensure that the vehicle is maintained in a clean and safe condition from both exterior and interior perspectives
 - Ensure that all drivers who drive a wheelchair accessible vehicle have satisfactorily completed training on how to safely restrain a wheelchair user

Use of information on and in relation to novelty private hire vehicles

- 1.21 Proprietors must obtain approval from the Council prior to displaying any information, advertisements, images or other material on their novelty private hire vehicle.
- 1.22 Materials that are used to display any information, advertisements, images or other material must be of a quality not easily defaced, soiled or detached.
- 1.23 Reflective material must not be used.
- 1.24 Signs used to display any information, advertisements, images or other material must not be illuminated.

- 1.25 Information, advertisements, images or other material may be affixed directly onto the exterior and/or internal body of the vehicle and must be in such a position as not to obscure Council issued plates and all other required signs.
- 1.26 Information, advertisements, images or other material must comply with the relevant requirements as set out in **Appendix L** of the Council's Policy.
- 1.27 Novelty private hire vehicles are prohibited from displaying the words 'taxi' or 'cab' in the singular or plural or the word 'hire' unless the word 'hire' forms part of the relevant company name or any word or similar meaning (e.g., 'kab') or appearance to any of these words, whether alone or as part of another word.
- 1.28 Proprietors must not permit any vehicle to be advertised as an 'executive vehicle' or 'executive travel' unless the vehicle is licensed as an executive private hire vehicle by the Council.

Closed circuit television (CCTV)

- 1.29 Proprietors wishing to install closed circuit television (CCTV) in their novelty private hire vehicle, must notify the Council, in writing, of their intention to do so.
- 1.30 The CCTV system must be installed in accordance with the appropriate legal framework.
- 1.31 Where CCTV is fitted, proprietors must maintain a valid registration with the Information Commissioners Office (ICO) throughout the duration of the licence or until such a time as the CCTV has been removed from the licensed vehicle.
- 1.32 Where a CCTV system is removed from a licensed vehicle, proprietors must notify the Council, in writing, within 7 days.

Trailers

- 1.33 Proprietors must ensure any trailer:
- Is inspected annually with the vehicle to which it relates
 - Has a plate that relates to the towing vehicle(s)
 - Complies with conditions applicable to the use of trailers set out in **Appendix M** of the Councils Policy

Meters

- 1.34 Whilst the fitting of meters is not mandatory in novelty private hire vehicles, if meters are fitted, then the following conditions apply:
- When the machinery of the meter is in action there must be recorded on the face of the meter in figures clearly legible and free from ambiguity, a fare not exceeding the rate of fare which the proprietor or driver is entitled to demand and take for the hire of the vehicle by distance.
 - The meter must be so placed that all the letters and figures on the face thereof shall be at all times plainly visible to any person being conveyed in the vehicle and for that purpose the letters and figures must be capable of being illuminated during any period of hiring.
 - The meter must be set to reflect the current private hire operator's tariff.

- Where there is a change to the private hire operator's tariff the meter must be re-calibrated to the new tariff and the meter checked against a measured distance before the vehicle can recommence private hire work.
- The proprietor of the vehicle must provide a valid certificate/report of compliance to the Council within 72 hours of the new private hire operator's tariff coming into effect, confirming the date the meter was calibrated to the new tariff.

Change of particulars

- 1.35 The proprietor of a licensed novelty private hire vehicle must notify the Council, in writing, of any change of particulars which may occur during the currency of their licence, including any change of address, change of phone number or change of email address within 7 days of such a change taking place.
- 1.36 A proprietor must notify the Council, in writing, of any change of partners, directors/company secretaries which may occur during the currency of their licence. Any such change must be notified within 7 days.

MOT

- 1.37 The vehicle must have a valid MOT throughout the licence period.
- 1.38 Vehicles must be submitted for an MOT inspection in accordance with the following:
- Vehicles, up to 9 years from date of first registration, must be submitted for an MOT inspection at 6-monthly intervals.
 - Vehicles 9 years of age or older from date of first registration, in addition to the MOT certificate submitted with an application, must have two additional MOT tests per year; tests being spaced evenly throughout the year at four monthly intervals.
- 1.39 A copy of the MOT certificate must be submitted to the Licensing Team within 10 working days of the date of issue from the MOT testing centre.

MOT failures and advisories

- 1.40 Where a vehicle has failed an MOT under the category dangerous (do not drive until repaired) defects, the proprietor of a licensed novelty private hire vehicle must ensure that the vehicle is not used as a novelty private hire vehicle until the repairs have been undertaken and a new MOT pass certificate issued.
- 1.41 Where a vehicle fails an MOT under the category major (repair immediately) defects, the proprietor of a licensed novelty private hire vehicle must ensure that the vehicle is not used as a novelty private hire vehicle until the repairs have been undertaken and a new MOT pass certificate issued.
- 1.42 The proprietor of a licensed private hire vehicle must, when requested by the Council, rectify any items listed under minor or advisory information on an MOT certificate and provide evidence that the work has been completed to the Council within a specified time.

Insurance

- 1.43 Satisfactory evidence must be produced that there is in force, for the use of the vehicle, a policy of insurance covering the carriage of passengers for hire or reward by pre-booking only or such security as complies with the requirements of Part VI of the Road Traffic Act 1988.
- 1.44 The proprietor must ensure that at all times a list is maintained of all licensed drivers authorised under the policy to drive the vehicle and must make such a list available to an authorised officer of the Council or a police officer at all reasonable times, when so required.
- 1.45 Proprietors must ensure that where a vehicle is insured by a proprietor and the proprietor allows another licensed Shropshire Council driver to drive their vehicle, or the vehicle is covered under a fleet insurance policy, drivers are aware of the content of the policy, including its limitations and exclusions. The proprietor must keep a record, signed by the driver, when this has been completed.

Smoking

- 1.46 The proprietor of a private hire vehicle must not permit the driver and passengers to smoke in the licensed vehicle (this includes electronic cigarettes and vaping).

Vehicle Excise Duty (Road Tax)

- 1.47 The vehicle must have valid Road Tax throughout the currency of the licence.

Alterations to vehicles

- 1.48 No material alteration or change in the mechanical or structural specification, design, condition or appearance of the vehicle is permitted without the prior approval of the Council, this includes but is not restricted to bull bars, running boards, side steps, side bars, LPG conversions and other similar alterations and changes.

Damage to vehicles

- 1.49 Notification must be given by the proprietor to the Council as soon as reasonably practicable on the Councils accident report form and in any case within 72 hours of the occurrence of any accident/damage to the vehicle that materially affects the safety, performance or appearance of the vehicle, or the comfort or convenience of persons carried therein and provide photographic evidence of the damage when requested by the Council.
- 1.50 Where a proprietor has notified the Council that a licensed vehicle has sustained structural damage from a road traffic accident resulting in a DVLA classification under Category S – Structural damage (vehicle that has sustained damage after 1 October 2017) or Category C (vehicle has sustained damage, rendering it beyond economical repair, prior to 1 October 2017), the vehicle must be submitted for a voluntary IVA inspection and a valid IVA certificate provided to the Licensing Team before the vehicle is permitted to be used as a novelty private hire vehicle.

Production of records/documents

- 1.51 All original supporting documentation provided upon application must be retained for the duration of the licence period and must be produced, on request, to any authorised officer of the Council or to any police officer.

Inspection/examination

- 1.52 The proprietor must permit any authorised officer of the Council or any police officer, at all reasonable times, to inspect and examine the vehicle and to request driver identification and insurance details. A drivers badge must be produced to an officer of the Council or any police officer during the inspection/examination. A drivers identification, certificate of insurance and MOT must be produced either during the inspection/examination to any authorised officer of the Council or any police officer or within 7 days to any authorised officer of the Council or any police officer.

APPENDIX G

PRIVATE HIRE OPERATOR LICENCE

CONDITIONS OF LICENCE

PRIVATE HIRE OPERATOR LICENCE - CONDITIONS OF LICENCE**General**

- 1.0 Additional information regarding all aspects of private hire operator licensing is available in the Council's Hackney Carriage and Private Hire Licensing Policy and this must be read in conjunction with the specific conditions set out below. Any legal requirements that apply to the operation of a private hire operator licence are regarded as if they are conditions of the licence, whether specifically listed below or in the policy or not. Where reference is made to legal requirements either in the conditions below or in the Council's policy, operators are advised that such references are not exhaustive and it is the operator's responsibility to ensure they are fully aware of all relevant legal requirements with which they must comply.
- 1.1 Where appropriate, any reference to 'employ' or 'employment' is deemed to include private hire drivers who may be contracted on a self-employed basis and used to fulfil bookings by a private hire operator.

Fit and proper person

- 1.2 Throughout the currency of the licence, the operator must be a fit and proper person to hold the licence. In this respect, the operator must have due regard to the relevant provisions of the Council's policy, be aware of the checks that will be undertaken by the Council and act in accordance with the responsibilities that being a fit and proper person would reasonably place on an operator.
- 1.3 Operators must provide a basic disclosure for all partners, directors/company secretaries and sole traders on an annual basis with the exception of holders of a hackney carriage/private hire drivers licence who are subject to an enhanced DBS.
- 1.4 An operator or where the operator is a partnership or a company, all partners or directors/company secretaries, as appropriate, during the currency of the licence must, within 48 hours, disclose to the Council, in writing, if:
- They receive any warnings, cautions, community resolutions, fixed penalties or driving endorsements (driving convictions)
 - Are arrested (whether or not charged with an offence)
 - Are charged with any criminal offence (includes driving/motoring offences)
 - Are convicted of any criminal offence (includes driving/motoring offences)
 - Allegations are made of their involvement in criminal activity
 - A licence issued by DVLA on behalf of the Office of the Traffic Commissioner, i.e., Passenger Carrying Vehicle (PCV) licence, Public Service Vehicle (PSV), is suspended or revoked or if they receive a written warning
 - A licence issued by another Local Authority is suspended or revoked or if they receive a written warning
- 1.5 Operators must comply with all reasonable requests made by officers of Shropshire Council and any police officer.

Convictions Policy

- 1.6 Operators must have a convictions policy that sets out the operator's position in relation to employment of ex-offenders.
- 1.7 Operators must provide all drivers, managers, office based administrative and telephony staff and agency staff, with details of the convictions policy.
- 1.8 The policy must include the following:
 - The steps that will be taken to ensure that any convictions are compatible with an operators policy on employing ex-offenders
 - A clear statement on the requirement of a driver, managers, office based administrative and telephony staff and agency staff to notify the operator of any convictions while they are employed in the role
 - How any new convictions will affect a driver, managers, office based administrative and telephony staff and agency staff employment status

Equalities Policy

- 1.9 Operators must have an equalities policy that sets out the operator's position in relation to hate crime and disability equality.
- 1.10 Operators must provide all drivers, managers, office based administrative and telephony staff and independent contractors with details of the equalities policy
- 1.11 The policy must include the following:
 - A clear statement that hate crime, including racist, homophobic and transphobic language, will not be tolerated
 - Details of the operators, drivers, vehicle proprietors, managers, office based administrative and telephony staff responsibilities with regard to hate crime and disability equality
 - Where drivers can report incidents of hate crime to when the driver is the victim
 - Where members of the public can report incidents of hate crime to when the member of the public is the victim

Designated person

- 1.12 Operators must have a suitably trained Designated Person (DP) with specific responsibility for safeguarding.
- 1.13 Operators must provide all drivers with details of the DP and how the DP can be contacted.
- 1.14 Operators must notify the Council in writing any change of DP which may occur during the currency of their licence. Any such change must be notified within 7 days.
- 1.15 Operators must ensure that the DP satisfactorily completes a safeguarding and disability awareness course every two years, unless the DP is the holder of a hackney carriage and private hire drivers licence issued by Shropshire Council and required to complete the training as part of the driver application process.

- 1.16 Operators must ensure that a record is maintained of all matters of concern received by the DP. The record should include, but is not restricted to, details of who reported the concern, date and time the concern was first identified, names and contact details of any persons relevant to the concern, details of any information disclosed together with all information relating to any action taken. Records must be made in a book/diary with consecutively numbered pages or in an appropriate electronic format. Where the records are kept electronically, they must be in an identifiable and secure format and must be capable of being reproduced in printed format at the request of an authorised officer of the Council or a police officer.

Safety of children, young persons and adults (including those with care and support needs)

- 1.17 Operators must take steps to ensure drivers know that they must report matters of concern which could relate to the safety of children, young persons and adults (including those with care and support needs) to the DP as soon as is practicable.
- 1.18 Operators must prominently display at their premises, where it is clearly visible to the licensed drivers, managers, office based administrative and telephony staff and independent contractors, information relating to the safety of children, young persons and adults (including those with care and support needs).
- 1.19 Operators must pass on any matters of concern reported to them which could relate to the safety of children, young persons and adults with care and support needs to the relevant authorities.

Contracting of private hire drivers and employment of other staff

- 1.20 For each private hire driver that an operator intends to use, the operator must examine the private hire drivers licence, issued by the Council, and ensure it is valid prior to agreeing to their employ. In addition, an operator must ensure that a copy of each drivers licence is lodged with the private hire operator business before the driver is employed to carry out private hire work and must retain the copy licence in their possession for the period during which the driver remains in their employ and for a period of at least 12 months thereafter.
- 1.21 Where an operator dismisses or terminates a contract with a driver they must report the dismissal and reasons for it to the Council within 7 days of the dismissal taking effect. In addition, an operator must inform the Council of any driver misconduct within 7 days of being made aware of the misconduct. Misconduct means any conduct that leads to the operator receiving a complaint about the driver from any person, agency or organisation or any conduct that the operator becomes aware of by any means that appears to indicate that the driver may have breached the requirements of this Policy or related conditions or any other conduct that appears to raise concerns about the driver's behaviour.
- 1.22 An operator must maintain an up to date register of all staff that will take bookings or dispatch vehicles.
- 1.23 An operator must make and retain individual records of the steps they have taken to demonstrate how they are satisfied that an individual, including all prospective private hire drivers, managers, office based administrative and telephony staff and agency staff, is a fit and proper person. These steps must include, but are not restricted to:
- Face to face interviews with individuals
 - Checks to ensure that the information provided by applicants is verified

- Independent professional and character references are requested and scrutinised
- Identity checks, right to work in the UK checks, national insurance number checks and relevant qualifications checks (if any) are verified as original documents
- Checks on previous employment history and experience
- Steps that are taken to verify that the individual has the health and physical capacity for the role
- A requirement of the employees contract of employment to notify the operator of any convictions while they are employed in the role
- A record of any discrepancies or anomalies, how they have been investigated and satisfactorily resolved

- 1.24 An operator must ensure that individual records of the steps they have taken to demonstrate how they are satisfied that an individual, including all private hire drivers, managers, office based administrative and telephony staff and agency staff, is a fit and proper person are available, on request, to any authorised officer of the Council.
- 1.25 An operator must ensure that all private hire drivers, managers, office based administrative and telephony staff and agency staff are fully aware that it is a condition of the operators licence to ensure that staff remain fit and proper and therefore the steps the operator has continually taken to achieve this will be retained and made available, upon request, to an authorised officer of the Council.
- 1.26 An operator must ensure that all new managers, office based administrative and telephony staff and agency staff have undertaken a basic criminal record check from the Disclosure and Barring Service (applicants can apply to <https://www.gov.uk/request-copy-criminal-record>) in order to satisfy the Council's 'fit and proper person' test as referred to in condition 1.23 above. The operator must keep a copy of the disclosure in the individual record file for each individual person. Where an individual ceases to be on the register referred to in condition 1.22 above, and re-entered, a new basic criminal record check must be requested and retained on the individual record file. An operator must be able to demonstrate that this condition has been met, on request, by any authorised officer of the Council.
- 1.27 An operator must ensure all private hire drivers, employees and agency staff are made aware of and fully understand the meaning of 'plying for hire' and, in particular, that private hire drivers are NOT permitted to 'ply for hire' under any circumstances. The operator is responsible for keeping a record within each individual's training record file when this has been completed. A copy of any individual's training records must be produced, on request, to any authorised officer of the Council. The Council's interpretation of 'plying for hire' is set out at **Appendix H** and is based on relevant legislation and case law.
- 1.28 An operator must ensure that all private hire drivers, employees and agency staff are made aware of the provisions of section 167 of the Criminal Justice and Public Order Act 1994 with respect to touting; in particular, that subject to certain provisions, it is an offence, in a public place, to tout people to hire their vehicles in order to carry them as passengers. The operator must keep a record within each individual's training record file when this has been completed. A copy of any individual's training records must be produced, on request, to any authorised officer of the Council.
- 1.29 An operator must ensure that all private hire drivers, managers, office based administrative and telephony staff and agency staff undertake training in the provisions of the General Data Protection Regulations (GDPR) within 7 days of commencement of employment. The operator

must keep a record within each individual's training record file when this has been completed. A copy of any individual's training records must be produced, on request, to any authorised officer of the Council.

- 1.30 An operator must ensure that all managers, office based administrative and telephony staff and agency staff undertake safeguarding and disability awareness training including exploitation (criminal and sexual exploitation), hate crime, equalities, in particular as it relates to disabilities, and modern day slavery and trafficking within 7 days of commencement of employment. The operator must keep a record within each individual's training record file when this has been completed. A copy of any individual's training records must be produced, on request, to any authorised officer of the Council.
- 1.31 An operator may outsource booking and dispatch functions but they cannot pass on the obligation to protect children, young persons and adults (including those with care and support needs). Operators must evidence that comparable protections are applied by the operator to which they outsource these functions.
- 1.32 An operator must ensure that all private hire drivers, managers, office based administrative and telephony staff and agency staff are fully aware that the information contained with an individual's training records file is made available, upon request, to an authorised officer of the Council.
- 1.33 Operators must ensure that all drivers, managers, office based administrative and telephony staff and independent contractors comply with all reasonable requests made by officers of Shropshire Council and any police officer.
- 1.34 An operator must take appropriate steps to ensure that drivers do not work excessively long hours and put the safety of themselves and their passengers at risk.

Operator's premises

- 1.35 Operators operating two vehicles or less are permitted to:
 - Divert the telephone number approved in the private hire operators licence to a single point of contact
 - Allow the single point of contact to receive bookings and instruct drivers to fulfil bookings
- 1.36 The single point of contact must be positioned/located within the Shropshire Council administrative area and must maintain the booking records in accordance with the conditions of licence.
- 1.37 Operators operating more than two vehicles must ensure that all private hire bookings taken by the operator are received at and drivers of private hire vehicles instructed to fulfil bookings from within the physical premises (which must be located within the Shropshire Council administrative area) to which the licence is applicable.
- 1.38 Under no circumstances is an operator permitted to receive bookings or instruct drivers to fulfil bookings from any premises other than the premises referred to in their licence and which is physically located within the Shropshire Council administrative area (unless they fulfil the criteria as set out at condition 1.35).

- 1.39 All records that may be required to be retained by the operator must be held within the physical business premises that is licensed for the purposes of the private hire operator business for inspection by an officer of the Council or a police officer. This is required even where the home or registered office address of the operator is also recorded within the licence as a separate address.
- 1.40 Operators must ensure that their licensed premises and any vehicles operated under their operators licence are not used for illegal or illicit purposes.

Display of licence

- 1.41 Operators must display their private hire operator licence in a prominent position at any premises from where they operate and make available for inspection by members of the public if requested:
- A copy of their private hire operator conditions
 - The conditions applicable to private hire vehicles, hackney carriages and drivers licences, whichever are applicable

Vehicles which may lawfully be used

- 1.42 An operator, licensed by the Council under the provisions of section 55 of the Local Government (Miscellaneous Provisions) Act 1976, must only use private hire vehicles that are licensed by the Council.
- 1.43 An operator must not permit the use of a public service vehicle (PSV), such as a minibus to undertake a private hire vehicle booking, without the informed consent of the hirer.
- 1.44 Operators must not cause or permit a person to use a motor vehicle when the licence has been suspended or revoked or on a road when there is no insurance in place in respect of third party risks or without a valid MOT or without the appropriate road tax.

Drivers who may lawfully be used

- 1.45 An operator, licensed by the Council under the provisions of section 55 of the Local Government (Miscellaneous Provisions) Act 1976, must only use drivers who hold a valid private hire vehicle drivers licence issued by the Council to drive a private hire vehicle that is licensed by the Council.
- 1.46 An operator must not permit a driver who holds a passenger carrying vehicle (PCV) licence, such as to drive a public service vehicle (PSV), to undertake a private hire vehicle booking, without the informed consent of the hirer. The hirer must be informed that a PCV driver is subject to different checks and not required to have an enhanced DBS check.

Taking bookings and retaining records

- 1.47 An operator MUST NOT accept any booking made by a driver on behalf of a passenger.
- 1.48 An operator accepting a booking remains liable for that booking, even if they sub- contract it to another operator.
- 1.49 An operator must make all reasonable provision that the booking system they have in place works effectively and that it enables any bookings that they accept to be honoured.

- 1.50 An operator must ensure that appropriate questions are asked at the booking stage as to whether a passenger requires assistance and, if so, what form of assistance is required, for example asking questions about the size of any wheelchair so that an appropriate sized vehicle can be allocated to the booking.
- 1.51 An operator MUST NOT fail or refuse to accept a booking made by, or on behalf of, a disabled person where the reason for failure or refusal is that the person is disabled or to prevent a driver from being subject to the duties imposed under the Equality Act 2010, as found in the Hackney Carriage and Private Hire Licensing Policy 2023-2027, Appendix B, hackney carriage and private hire drivers licence - conditions of licence, conditions 1.19 and 1.23.
- 1.52 An operator MUST NOT make, or propose to make, an additional charge for the carrying out of any duty imposed on the driver of the private hire vehicle or pre-booked hackney carriage under the Equality Act 2010.
- 1.53 An operator must monitor the booking system to ensure that drivers and vehicles are available to fulfil the arrangements that are agreed with customers.
- 1.54 An operator must ensure that all relevant information is passed on the driver at the point of allocation of the booking and prior to commencement of the journey.
- 1.55 Immediately prior to the commencement of each journey, an operator licensed with the Council must keep records of any booking they accept. Such records must be kept either in a ledger with consecutively numbered pages, on individual consecutively numbered record slips, or in electronic format such as a computer database/spreadsheet. Where the records are kept electronically, they must be in an identifiable and secure format and must be capable of being reproduced in printed format at the request of an authorised officer of the Council or a police officer. Irrespective of the format of the records, all such records must be available at all reasonable times to an authorised officer of the council or to any police officer for inspection.
- 1.56 In respect of bookings made by telephone, website or by App, the following particulars must be recorded:
- a) Time and date of each booking
 - b) Name of the hirer
 - c) How the booking was made (telephone, in person, etc)
 - d) Time, date and place of pickup
 - e) Destination of the hirer
 - f) A unique journey reference number must be allocated to each journey
 - g) Call sign or registration number of the vehicle used for each booking
 - h) Full name of the driver allocated to the booking
 - i) The name of any individual that responded to the booking request
 - j) The name of any individual that dispatched the vehicle
 - k) Any other comments relevant to the booking, including details of specific instructions from the hirer or sub-contracting arrangements with another operator
 - l) Global Positioning System (GPS) data must be retained following completion of a journey
- 1.57 In respect of bookings being made by Interactive Voice Response (IVR) the following particulars must be recorded:
- a) Time and date of each booking

- b) Name of the hirer
- c) How the booking was made (telephone, in person, etc)
- d) Time, date and place of pickup
- e) The destination of the hirer, recorded by a Global Positioning System (GPS) tracking system, must post populate the booking record at the conclusion of the journey with the actual destination
- f) A unique journey reference number allocated to each journey
- g) Call sign or registration number of the vehicle used for each booking
- h) Full name of the driver allocated to the booking
- i) The name of any individual that dispatched the vehicle
- j) Any other comments relevant to the booking, including details of specific instructions from the hirer or sub-contracting arrangements with another operator
- k) Global Positioning System (GPS) data must be retained following completion of a journey

1.58 In respect of bookings being made by other electronic means, e.g., “taxi butler” or equivalent device, the following particulars must be recorded:

- a) Time and date of each booking
- b) How the booking was made (telephone, in person, etc)
- c) Time, date and place of pickup
- d) The destination of the hirer, recorded by a Global Positioning System (GPS) tracking system, must post populate the booking record at the conclusion of the journey with the actual destination
- e) The unique reference number allocated to each journey
- f) Call sign or registration number of the vehicle used for each booking
- g) Full name of the driver allocated to the booking
- h) The name of any individual that dispatched the vehicle
- i) Any other comments relevant to the booking, including details of specific instructions from the hirer or sub-contracting arrangements with another operator
- j) Global Positioning System (GPS) data must be retained following completion of a journey

Executive vehicles

1.59 The operator must not permit any executive plated vehicles to fulfil general private hire bookings.

1.60 Executive vehicles must only be used for executive service which is defined as the provision of a vehicle or vehicles that is/are **exclusively** used for executive private hire work and **not** for ‘normal’ or general-purpose private hire use.

1.61 Bookings taken in respect of clients who require an executive private hire must be paid for on account. No payment can be made to the driver of the vehicle at time of hiring.

1.62 Copies of invoices and/or any business-to-business contracts must be retained and made available at all reasonable times to an authorised officer of the Council or to any police officer for inspection.

Novelty vehicles

1.63 The operator must not permit any novelty plated vehicles to fulfil any executive or general private hire bookings.

- 1.64 Novelty vehicles must only be used for special events, which are defined as the provision of a vehicle or vehicles for events such as, but not limited to, weddings, proms, anniversaries, birthdays, stag and hen parties and **not** for 'normal' or general-purpose private hire use.
- 1.65 Bookings taken in respect of clients who require a novelty private hire must require a deposit to be paid for in advance.

Records for Passenger Transport contracts

- 1.66 Immediately prior to the commencement of each journey, an operator licensed with the Council must keep details of the contract and the driver and passenger assistant who fulfilled each journey. Such records must be kept either in a ledger with consecutively numbered pages, on individual consecutively numbered record slips, or in electronic format such as a computer database/spreadsheet. Where the records are kept electronically, they must be in an identifiable and secure format and must be capable of being reproduced in printed format at the request of an authorised officer of the Council or a police officer. Irrespective of the format of the records, all such records must be available at all reasonable times to an authorised officer of the Council or to any police officer for inspection.

Records of vehicles and drivers

- 1.67 The operator must keep and maintain at their licensed premises up to date records of the particulars of all their drivers and vehicles whether or not the vehicle is owned by the operator. The records to be kept must include:
- a) Private hire vehicle or hackney carriage vehicle licence plate numbers
 - b) Vehicle descriptions (make/model) and vehicle registration numbers
 - c) Where relevant, any radio or computer call sign used to identify vehicles or drivers
 - d) Full names and addresses of the proprietors of each vehicle
 - e) Full names and addresses of the private hire and hackney carriage drivers used
 - f) Copies of the private hire and hackney carriage drivers licences, issued by the Council, relating to the drivers in their employ
 - g) Drivers licence numbers (badge number) of the private hire and hackney carriage drivers relating to the drivers in their employ
 - h) Copies of current/valid insurance documents for all vehicles
 - i) Written evidence that each driver has satisfactorily completed basic safeguarding and disability awareness training
 - j) Written evidence that each driver who drives a wheelchair accessible vehicle has satisfactorily completed training on how to safely restrain a wheelchair user
- 1.68 An operator must notify the Council within 72 hours when any vehicle or driver commences in their employ. Any other changes relating to licensed vehicles and drivers, to include when a vehicle or driver ceases to be in their employ, must be notified to the Council within 7 days.
- 1.69 An operator must notify the Council, within 7 days of the date of notification, of any change of address relating to any driver or vehicle proprietor they employ or allow to operate within the business.
- 1.70 An operator must provide to the Council a complete and up to date list of all drivers and vehicles employed by the business when requested to do so by an officer of the Council.

Retention of records

- 1.71 All records kept by the operator under conditions 1.56 to 1.58, 1.62, 1.66 and 1.67 above must be retained for a period of not less than 6 months for licensing purposes. Other legislation may require records to be kept for a longer period.
- 1.72 All records kept by the operator under conditions 1.56 to 1.58, 1.62, 1.66 and 1.67 above must be kept in accordance with the General Data Protection Regulations (GDPR).

Standards of service

- 1.73 The operator must provide prompt, efficient and reliable service to members of the public at all reasonable times and for this purpose must in particular:
- Provide adequate information and communications technology, facilities and staff, as appropriate
 - Ensure the highest level of customer service and care
 - Ensure that when a private hire vehicle has been hired to be in attendance at an appointed time and place, the vehicle shall, unless delayed or prevented by sufficient cause, punctually attend at that appointed time and place
 - Where a waiting area or room is provided to which the public has access for the purposes of booking or waiting, must ensure that the area/room:
 - is kept in a good state of repair (interior and exterior)
 - is kept clean, adequately heated, ventilated and lit
 - has adequate seating facilities
 - is kept physically separated from any driver rest areas and radio operation rooms
 - is arranged in such a manner that staff, drivers and vehicle proprietors do not congregate within such areas
 - a no smoking (including electronic cigarettes and vaping) policy that complies with the Health Act 2006 and the Smoke-Free (Exemptions and Vehicles) Regulations 2007 operates
 - Ensure that any telephone facilities and radio equipment (for which an OFCOM Radio Licence may be required) are maintained in a sound condition and that any defects are repaired promptly
 - Where a private hire operator wishes to operate a pre-payment system, notification must be provided to the hirer indicating the period and under what circumstances this is applicable, e.g., pre-payment required between the hours of 1900 to 0700. This does not mean pre-payment between these hours is compulsory

Complaints

- 1.74 Operators must set up an effective internal complaints procedure to deal with complaints made by the public against the business, vehicle proprietors and/or drivers. Wherever possible, the procedure must be set up in such a way that complaints are dealt with by the operator or a member of staff not directly connected with the taking of private hire bookings or the despatching of drivers and vehicles. An operator must monitor and review the complaints procedure to ensure it is operating effectively and make changes where necessary to ensure continued effectiveness.
- 1.75 Operators must ensure that all complaints received are properly recorded. This must include details of the booking (who accepted it on behalf of the business), vehicle details and driver details

together with all information relating to any action taken. Records must be made in a book/diary with consecutively numbered pages or in an appropriate electronic format. Where the records are kept electronically, they must be in an identifiable and secure format and must be capable of being reproduced in printed format at the request of an authorised officer of the Council or a police officer. Complaint records must be made available, upon request, to any authorised officer of the Council or police officer and may be used to assist officers in the investigation of complaints.

- 1.76 The operator or an appointed representative from within the business must, as soon as reasonably practicable, investigate any complaint. The complainant must be kept informed and the outcome of the complaint must be notified, within a reasonable time, to both the complainant and the Council.
- 1.77 The operator must when investigating a complaint concerning a private hire contract, or purported contract, relating to, or arising from their business, make it clear to the complainant of their right to forward their complaint to the Council.
- 1.78 Where a complaint is received by the Council, the operator must comply with any reasonable request for information and/or follow any reasonable directions/instructions made by an authorised officer or police officer in respect of the complaint.

Change of operators business address

- 1.79 An operator must not commence operating from a new business address without first consulting the Council as to the legal implications of such a change of address.
- 1.80 An operator must notify the Council, in writing, of the sale of their business within 7 days of such an event taking place.

Change of particulars

- 1.81 Operators must notify the Council, in writing, of any change in their home address which may occur during the currency of their licence. Any such change must be notified within 7 days.
- 1.82 Operators must notify the Council, in writing, of any change to its office address registered with Companies House which may occur during the currency of their licence. Any such change must be notified within 7 days.
- 1.83 Operators must notify the Council, in writing, of any change of partners, directors/company secretaries which may occur during the currency of their licence. Any such change must be notified within 7 days.
- 1.84 Operators must notify the Council, in writing, of any change to the operators trading name as listed on the private hire operators licence which may occur during the currency of their licence. Any such change must be notified within 7 days.

Use of the words 'taxi', 'cab and 'hire'

- 1.85 No operator shall cause or permit any information, advertisement, images or other material to be displayed in respect of their business in or on their private hire vehicles used for that purpose the words 'taxi' or 'cab' in the singular or plural or 'hire' unless the word 'hire' forms part of the

company name or any word or similar meaning (e.g. 'kab') or appearance to any of these words, whether alone or as part of another word.

Use of information on and in relation to hackney carriages and private hire vehicles

- 1.86 Information, advertisements, images and other material must comply with the relevant requirements as set out in **Appendix L** of the Council's Policy.
- 1.87 Any advertising of the operator's business, no matter in what form, shall include the operator's name and/or trade name as approved by the Council in accordance with the name entered on the operator's licence issued by the Council.
- 1.88 Any change to an operators advertising/promotion must comply with the conditions set out in **Appendix L**. This is subject to prior written approval from the Council.
- 1.89 No operator shall permit any telephone number to be advertised on any private hire vehicle except the telephone number approved in the private hire operators licence.
- 1.90 No operator shall permit any vehicle to be advertised as an 'executive vehicle' or 'executive travel' unless the vehicle is licensed as an executive private hire vehicle by the Council.

Closed circuit television (CCTV)

- 1.91 Operators wishing to install closed circuit television (CCTV) in premises where passengers have access to make bookings or wait must notify the Council, in writing, of their intention to do so.
- 1.92 The CCTV system must be installed in accordance with the appropriate legal framework.
- 1.93 Where CCTV is fitted, operators must maintain a valid registration with the Information Commissioners Office (ICO) throughout the duration of the licence or until such a time as the CCTV has been removed from the premises.
- 1.94 Where a CCTV system is removed from the premises, operators must notify the Council, in writing, within 7 days.

Lost Property

- 1.95 Operators must have a lost property policy that sets out the operator's position in relations to the process that all private hire drivers, managers, office based administrative and telephony staff and agency staff must follow when dealing with lost property. The lost property policy must include retention periods and how the property was disposed of.
- 1.96 Operators must keep and maintain at their licensed premises a record of lost property detailing the date and time, the item found, the vehicle details and action taken to return the item to the rightful owner, to the police or disposal.
- 1.97 Where licensed drivers of private hire vehicles have handed property belonging to passengers to their operator or an operator finds such property themselves, an operator must take the necessary steps to establish the identity of the owner of the property. If, however, the operator is not able to establish the identity of the owner, any property of high value or that contains a serial number should be handed into the police.

Transporting children

- 1.98 Operators must take steps to ensure their drivers understand and inform parents/carers that the decision to permit children to travel in the vehicle, without the correctly sized seat restraints (as permitted by relevant legislation) and with the obvious risks associated with such an action, remains with the parent/carer responsible for the children and not with the driver of the vehicle.

Meters

- 1.99 Whilst the fitting of meters is not mandatory in private hire vehicles, if meters are fitted, then the following conditions apply:
- The meter must be set to reflect the current private hire operator's tariff.
 - The operator must notify the Council, in writing, at least 7 days prior to any proposed change to the private hire operator's tariff. A copy of the proposed tariff and a schedule of any affected vehicles must be provided with the notice.
 - Where there is a change to the private hire operator's tariff all vehicles with meters fitted must have their meters re-calibrated to the new tariff and the meter checked against a measured distance before the vehicle can recommence private hire work.
 - The proprietor of the vehicle must provide a valid certificate/report of compliance to the Council within 72 hours of the new private hire operator's tariff coming into effect, confirming the date the meter was calibrated to the new tariff.

Insurance

- 1.100 Operators must ensure that at all times there is in force, for all private hire vehicles operated, a policy of insurance covering the carriage of passengers for hire or reward by pre-booking only or such security as complies with the requirements of Part VI of the Road Traffic Act 1988.
- 1.101 Any premises that provide access to members of the public must be covered by Public Liability insurance for a minimum of £5,000,000. The operator must also obtain information as to any requirement for them to have Employers Liability indemnity; if there is such a requirement it must be for a minimum of £1,000,000.
- 1.102 Operators must ensure that where a vehicle is covered under a fleet insurance policy, drivers are aware of the content of the policy, including its limitations and exclusions. The operator must keep a record, signed by the driver, within each individual's record file when this has been completed. A copy of any individual's records must be produced, on request, to any authorised officer of the Council.

MOT

- 1.103 Operators must ensure that at all times there is in force, for all private hire vehicles operated, a valid MOT issued in accordance with the requirements set out at paragraph 3c.47 of the Hackney Carriage and Private Hire Licensing Policy 2023-2027.

Damage to vehicles

- 1.104 Operators must notify the Council within 48 hours of notification by a driver or proprietor of the occurrence of any accident/damage to a private hire vehicle under their control that materially

affects the safety, performance or appearance of the vehicle, or the comfort or convenience of persons carried therein and provide photographic evidence of the damage when requested by the Council.

APPENDIX H

PLYING FOR HIRE

PLYING FOR HIRE

- 1.0 Only licensed hackney carriages are permitted to ply for hire. It is ILLEGAL for a private hire vehicle to ply for hire. This means:
- a) Private hire vehicles MUST NOT carry passengers if the journey has not been pre-booked with a private hire operator by the passenger.
 - b) All private hire vehicle journeys MUST be pre-booked through a licensed private hire operator.
 - c) All bookings MUST be made by prospective passengers themselves directly with a private hire operator who will despatch the vehicle. Prospective passengers may instruct a third party, e.g. a restaurant manager, to make a booking on their behalf but this third party MUST NOT be the private hire vehicle driver.
 - d) A driver of a private hire vehicle is NOT permitted to make the booking on behalf of a prospective passenger, e.g., via their radio or mobile telephone.
 - e) Private hire operators MUST NOT accept any booking made by a driver on behalf of a passenger.
 - f) Private hire vehicle drivers are NOT permitted to make their vehicles available for immediate hire. This means that private hire vehicle drivers MUST NOT physically position their vehicles in such a way as to be waiting in any area that is on view to the public to invite custom, e.g., allowing prospective customers to approach the vehicle and ask, 'Are you free?'
 - g) In most cases, the vehicle will not be insured during a journey that has not been correctly pre-booked.
 - h) Private hire vehicles MUST NOT wait at any taxi rank/stand.
 - i) Private hire vehicle MUST NOT be hailed in the street.
- 1.1 Other circumstances may constitute unlawful 'plying for hire'; accordingly, each case of allegedly unlawful 'plying for hire' will be judged on its own facts. Nevertheless, attention is drawn to the Council's position as set out above.
- 1.2 Further information about the relevant legislation is available in the Town Police Clauses Act 1847, in particular Section 45, and in Part II of the Local Government (Miscellaneous Provisions) Act 1976, in particular Section 64.

APPENDIX I

GUIDANCE TO DETERMINING THE SUITABILITY OF APPLICANTS INCLUDING THE RELEVANCE OF CRIMINAL CONVICTIONS AND CAUTIONS

GUIDANCE TO DETERMINING THE SUITABILITY OF APPLICANTS INCLUDING THE RELEVANCE OF CRIMINAL CONVICTIONS AND CAUTIONS

Introduction

- 1.0 The purpose of this appendix is to provide additional guidance to determine whether or not an applicant or an existing licence holder is a fit and proper person to hold a hackney carriage drivers licence, private hire drivers licence, hackney carriage vehicle licence, private hire vehicle licence and/or a private hire operator licence. Where appropriate, any reference to 'applicant' is deemed to include existing licence holders. In respect of proprietors and operators 'applicant' also includes any partners, directors/company secretaries.
- 1.1 The guidance has been produced to assist the Council in its decision-making and to maintain the consistency of the decisions made. It has also been formulated to provide clearer information to current and potential applicants, with a view to minimising the cost and time spent on the licensing process by both the Council and the applicant.
- 1.2 When assessing the fitness of an applicant to hold a licence, the Council will consider the applicant's entire character and criminal history as a whole, together with all other relevant evidence, information and intelligence including their history (e.g., complaints and positive comments from the public, compliance with licence conditions and willingness to co-operate with licensing officers) whilst holding a licence from the Council or any other authority. Particular attention will be given to patterns of behaviour, irrespective of the timescale over which they have occurred, both in terms of proven criminal offences and other behaviour/conduct that may indicate the safety and welfare of the public may be at risk from the applicant.
- 1.3 It must also be recognised that the Council will consider all criminal history, behaviour and conduct irrespective of whether the specific history, behaviour or conduct occurred whilst the applicant was directly engaged in hackney carriage or private hire licensed work at the time or whether they occurred during the applicants own personal time.
- 1.4 Applicants are expected to demonstrate appropriate professional conduct at all times, whether in the context of their work or otherwise. Applicants should be courteous, avoid confrontation, not be abusive or exhibit prejudice in any way. In no circumstances should applicants take the law into their own hands. Applicants are expected to act with integrity and demonstrate conduct befitting the trust that is placed in them.
- 1.5 For the purposes of this Policy, driving endorsements is the term used for all driving convictions.
- 1.6 The aim of the guidance is not to punish the applicant twice for a conviction or caution but to ensure that public safety is not compromised. The Council cannot review the merits of any conviction.
- 1.7 Each case is to be decided on its own individual merits and when making a decision will determine what action is appropriate and proportionate to the circumstances of the case. Where the circumstances demand, the decision-making body may depart from the guidance in which case the reasons for this will be made clear.

Legislation

- 1.8 Sections 51, 55 and 59 of the Local Government (Miscellaneous Provisions) Act 1976 sets out that the Council must not grant a driver's licence or an operator's licence unless they are satisfied that the person is a **fit and proper person** to hold such a licence.
- 1.9 Section 61 of the Local Government (Miscellaneous Provisions) Act 1976 allows the Council to suspend, revoke or refuse to renew a driver's licence if they have, since the grant of the licence, been convicted of an offence involving dishonesty, indecency or violence; or been convicted of an offence under or failed to comply with the provisions of the Town Police Clauses Act 1847 or Part II of the Local Government (Miscellaneous Provisions) Act 1976, been convicted of an immigration offence or required to pay an immigration penalty; or any other reasonable cause.
- 1.10 Section 62 of the Local Government (Miscellaneous Provisions) Act 1976 allows the Council to suspend, revoke or refuse to renew an operator's licence if they have committed any offence under, or failed to comply with, the provisions of Part II of the Act; where any conduct appears to render the operator unfit to hold a licence; any material change since the licence was granted in any of the circumstances of the operator on the basis of which the licence was granted; or any other reasonable cause.
- 1.11 Therefore, the wording of the legislation makes it clear that the Council may grant a licence ONLY if it is satisfied that the person is fit and proper; the onus is on the applicant to prove this, NOT the Council to demonstrate that they are not.
- 1.12 Section 37 of the Town Police Clauses Act 1847 and section 48 the Local Government (Miscellaneous Provisions) Act 1976 do not set out specific criteria to determine the suitability of an applicant for a hackney carriage or private hire vehicle licence, the Council has the absolute discretion. The Policy sets out the Council's position in this regard.

Defining a 'fit and proper person'

- 1.13 There is no legal definition as to what definitively constitutes a 'fit and proper person'. However, because of the potential vulnerability of the passengers that drivers, proprietors and operators may come into contact with and who they have significant control over, e.g. elderly people, unaccompanied children, the disabled, those who may have consumed excessive quantities of alcohol, lone females and foreign visitors, it is incumbent on the Council to take a very robust stance when deciding whether a person is fit and proper to hold a licence granted by the Council and not a person who would take advantage of their employment to abuse or assault passengers.
- 1.14 In essence, a fit and proper person:
- Is honest and trustworthy – drivers, proprietors and operators have, for example, access to a large amount of personal information that could be misused and significant opportunities to defraud drunken, vulnerable or foreign people or to steal property left in cars. Conversely, a failure by a licence holder to disclose an arrest might be seen as behaviour that questions honesty and, therefore, the suitability of the licence holder regardless of the outcome of the initial allegation.
 - Is not abusive, violent, threatening, intimidating, prejudiced or discriminatory – exhibiting abusive, violent, threatening, prejudiced or discriminatory behaviour in any way, including online or on social media, is not acceptable conduct on the part of a driver/operator even when they are subjected to unpleasant or dishonest passenger behaviour.

- Will not be involved in or connected to any form of illegal sexual activity or any form of indecency.
- Will not abuse, exploit, misuse or maltreat another individual irrespective of whether the individual is an adult or a child – this includes hate crime, slavery, child sexual exploitation, grooming and psychological, emotional or financial abuse.
- Will not engage in activities that intend or does result in the death or serious injury of another person.
- Will not be in illegal possession of any weapon or commit any other weapon related offence.
- Does not manufacture, supply or possess controlled drugs. Will not use or permit their licensed vehicle to be used or connected with the use of any illegal activity – licensed vehicles are seen in any location across the country, at all times of the day and night. Therefore, licensed vehicles could provide a transportation system for illegal activities or any form of contraband, whether that is drugs, guns, illicit alcohol or tobacco, or people who are involved in or are the victims of illegal activity, or children who may be at risk of being, or are being, abused or exploited.
- Will not be involved in or linked to acts of terrorism.
- Is a competent and safe driver - they are expected to be professional drivers and must be fully aware of all relevant licensing legislation, road traffic legislation, conditions attached to their driving licence, the safety of their passengers and the safety of their vehicles at all times; passengers rely on their driver to get them to their destination safely and using the most direct route, therefore, a good knowledge of the area that they are working in is also appropriate.
- Is able to communicate effectively with passengers – principally, this means able to read, speak, write and understand English.
- Is able to communicate effectively with disabled passengers when providing assistance – a driver must be able to understand a disabled persons needs by asking passengers what help they need, to listen to and understand the response and to act on what they have been asked to do, seeking clarification where necessary, on how to provide what is needed.
- Is in good physical and mental health, not under the influence of drugs or alcohol – to ensure they do not put passengers at risk through, for example, suffering a heart attack or diabetic hypoglycaemic incident, whilst conveying passengers.
- Will not abuse their position of trust – applicants are expected to be respectful, act with integrity and demonstrate considerate, courteous and civil conduct befitting the trust that is placed in them. Applicants must not use passengers personal information which has been obtained whilst undertaking hackney carriage or private hire work for their own personal use, e.g., contacting customers through social media, text messaging, home addresses, etc.

1.15 The bullet points listed above are not exhaustive and are used to illustrate some of the behaviours the Council will consider.

1.16 Licensed drivers and private hire operators and proprietors of licensed vehicles provide a public service and all impact directly on public safety. On this basis, the Council will not licence anyone to drive a hackney carriage or private hire vehicle or act as a private hire operator or licence a vehicle unless it is satisfied that the driver, operator or vehicle proprietor respectively meet **all** relevant criteria to be deemed a fit and proper person.

1.17 In addition, an important element associated with the fitness to hold a licence is the appearance and behaviour of anyone who holds a licence. Consequently, the Council requires all licensed drivers, private hire operators and vehicle proprietors to maintain a reasonable standard of

appearance and behaviour when in contact and dealing with all persons, including but not limited to, other road users, pedestrians, customers, the general public, other licensed operators and drivers of hackney carriage and private hire vehicles, Council officers and elected members at all times.

- 1.18 Applicants and licence holders must also co-operate with any reasonable request made by an authorised officer of the Council, Civil Enforcement Officers or any police officer.

Hackney carriage and private hire drivers

- 1.19 In considering the fit and proper person test all applicants on initial application and renewal must complete an enhanced Disclosure and Barring Service (DBS) check. The Council will also make additional enquiries through the national register for hackney carriage and private hire licence revocations, refusals and suspensions (or equivalent if this is replaced), its adults and childrens social care teams, directly with West Mercia Police (and other relevant police forces, where appropriate), other relevant local authorities (particularly Telford & Wrekin Council and City of Wolverhampton Council) and any other appropriate organisation, agency or person in order to ensure the Council is in a position to make as accurate an assessment of the applicant's fitness to hold a licence as is reasonably practicable.
- 1.20 With specific reference to existing licence holders, where there is any cause for a licence to be reviewed, the Council will make additional enquiries through the national register for hackney carriage and private hire licence revocations, refusals and suspensions (or equivalent if this is replaced), its adults and childrens social care teams, directly with West Mercia Police (and other relevant police forces, where appropriate), other relevant local authorities (particularly Telford & Wrekin Council and City of Wolverhampton Council) and any other appropriate organisation, agency or person in order to ensure the Council is in a position to make as accurate an assessment of the licence holders fitness to hold a licence as is reasonably practicable. The Council may request the licence holder to consent to a further enhanced DBS check the cost of which lies with the licence holder. Where a licence holder refuses to consent to a further check the Council will take this into consideration in determining their continuing fitness to hold a licence.
- 1.21 Where an applicant or an existing hackney carriage and private hire driver has had their licence refused or revoked the details will be recorded on the national register for hackney carriage and private hire licence revocations, refusals and suspensions (or equivalent if this is replaced). Furthermore, where the Council deems it necessary it will notify any relevant authorities or appropriate organisations of the reasons for refusal or revocation.

Vehicle proprietors

- 1.22 In considering the fit and proper person test, all applicants on initial application must provide a basic criminal record disclosure from the Disclosure and Barring Service (for partnerships or companies, the requirements apply to all partners and directors/company secretaries). All applicants on renewal must provide a basic criminal record disclosure that has been issued by the Disclosure and Barring Service within the previous 12 months of the date that the application is received by the Council. On new and renewal applications the Council will also make additional enquiries through its adults and childrens social care teams, directly with West Mercia Police (and other relevant police forces, where appropriate), other relevant local authorities (particularly Telford & Wrekin Council and City of Wolverhampton Council) and any other appropriate organisation, agency or person in order to ensure the Council is in a position to make as accurate an assessment of the applicant's fitness to hold a licence as is reasonably practicable.

- 1.23 With specific reference to existing licence holders, where there is any cause for a licence to be reviewed, the Council will make additional enquiries through its adults and childrens social care teams, directly with West Mercia Police (and other relevant police forces, where appropriate), other relevant local authorities (particularly Telford & Wrekin Council and City of Wolverhampton Council) and any other appropriate organisation, agency or person in order to ensure the Council is in a position to make as accurate an assessment of the licence holders fitness to hold a licence as is reasonably practicable. Depending on the circumstances of the case, the Council may request the licence holder to consent to a further basic criminal record disclosure, the cost of which lies with the licence holder. Where a licence holder refuses to consent to a further check the Council will take this into consideration in determining their continuing fitness to hold a licence.

Private hire operators

- 1.24 In considering the fit and proper person test, all applicants, on initial application must provide a basic criminal record disclosure from the Disclosure and Barring Service (for partnerships or companies, the requirements apply to all partners and directors/company secretaries). All applicants on renewal must provide a basic criminal record disclosure that has been issued by the Disclosure and Barring Service within the previous 12 months of the date that the application is received by the Council. On new and renewal applications the Council will also make additional enquiries through its adults and childrens social care teams, directly with West Mercia Police (and other relevant police forces, where appropriate), other relevant local authorities (particularly Telford & Wrekin Council and City of Wolverhampton Council) and any other appropriate organisation, agency or person in order to ensure the Council is in a position to make as accurate an assessment of the applicant's fitness to hold a licence as is reasonably practicable.
- 1.25 With specific reference to existing licence holders, where there is any cause for a licence to be reviewed, the Council will make additional enquiries through its adults and childrens social care teams, directly with West Mercia Police (and other relevant police forces, where appropriate), other relevant local authorities (particularly Telford & Wrekin Council and City of Wolverhampton Council) and any other appropriate organisation, agency or person in order to ensure the Council is in a position to make as accurate an assessment of the licence holders fitness to hold a licence as is reasonably practicable. Depending on the circumstances of the case, the Council may request the licence holder to consent to a further basic criminal record disclosure, the cost of which lies with the licence holder. Where a licence holder refuses to consent to a further check the Council will take this into consideration in determining their continuing fitness to hold a licence.

The Council's approach when considering convictions

- 1.26 The disclosure of any convictions or cautions will not necessarily mean an applicant is not a fit and proper person and, therefore, automatically prevented from being issued a licence.
- 1.27 Hackney carriage and private hire drivers are required to undertake an enhanced criminal record disclosure (DBS check) and due to the nature of the occupation such drivers are deemed to be an exempt occupation under the provisions of the Rehabilitation of Offenders Act 1974 (by virtue of the amended Rehabilitation of Offenders Act 1974 (Exceptions) Order 1975).
- 1.28 The effect of this, in relation to hackney carriage and private hire drivers, is to render the Rehabilitation of Offenders Act 1974 inapplicable and therefore convictions are deemed never to be spent, unless they are considered a protected conviction or caution. As a result, all convictions, including cautions, which are not protected will be taken into account when considering a person's

suitability to hold a driver’s licence. Consequently, applicants are required to provide details of all unprotected convictions and cautions, including driving endorsements (driving convictions) and disqualification periods relating to traffic offences.

1.29 Proprietors and private hire operators are required to undertake a basic criminal record disclosure (DBS check). As a result, all unspent convictions and cautions will be taken into account when considering a person’s suitability to hold a proprietors or private hire operators licence.

1.30 A refusal to licence an individual as a hackney carriage and driver hire driver or to suspend or revoke a hackney carriage and driver hire driver’s licence does not automatically mean that that individual cannot be issued or continue to hold a vehicle or private hire operator licence. Officers with delegated authority will make a decision based on the appropriate information in accordance with the table set out at 1.32 below.

1.31 The Council will have regard to all unprotected convictions and cautions, and unspent convictions and cautions, as set out in tables 1.32 and 1.33 below, and they will be assessed accordingly. Consideration will be given, but not restricted to, the following:

- How relevant the offence(s) are to the licence being applied for?
- How serious the offence (s) were?
- When the offence(s) were committed?
- The date of conviction
- The extent of any mitigating factors
- Sentence imposed by the court
- The applicants age at the time of conviction
- Whether the offence(s) form part of a pattern of offending or indicate a pattern of unacceptable behaviour
- Any other character check considered reasonable, e.g., personal references
- Any other factor that may be relevant

Convictions and cautions that need to be disclosed

1.32 The table below sets out the conviction and caution information the Council can request and which you are required to disclose:

	Unspent convictions and cautions	Unprotected convictions and cautions	Protected* spent convictions and cautions
Hackney carriage/private hire drivers	Yes	Yes	No
Hackney carriage/private hire vehicle proprietors	Yes	No	No
Private hire operators	Yes	No	No

*Protected spent convictions and cautions include but are not restricted to youth reprimands, warnings and cautions

1.33 In addition, any spent convictions and cautions must be disclosed if they meet the circumstances described in the table below:

Disposal	Age when given/sentenced	How long since given/sentences?
-----------------	---------------------------------	--

Caution for specified offence*	18 or over	Any time
Caution for a non-specified offence	18 or over	Less than 6 years
Conviction for specified offence*	Any age	Any time
Conviction resulting in custodial sentence	Any age	Any time
Conviction for non-specified offence	18 or over	Less than 11 years
	Under 18	Less than 5½ years

* A specified offence is one which is serious and which relates to sexual offending, violent offending and/or are relevant to safeguarding children and vulnerable adults. The full list of these specified offences can be found on the DBS website. <https://www.gov.uk/government/publications/filtering-rules-for-criminal-record-check-certificates>

NB Any other caution or conviction which does not meet the details set out in the table, such as spent youth reprimands, warnings and cautions, is considered protected.

The Council's approach when considering non-conviction information

1.34 An applicant's previous behaviour and their potential to cause harm as a result of the choices they have made plays a significant part when making a decision as to whether an applicant is a fit and proper person to hold a licence. Consideration will be given, but not restricted to, the following:

- Circumstances surrounding the behaviour demonstrated
- When the behaviour was demonstrated
- The extent of any mitigating factors
- Steps taken to address any issues identified
- An applicant or existing licence holder's ability to sustain the required behavioural change
- The applicants age at the time the behaviour was demonstrated
- Whether the behaviour forms part of a pattern of unacceptable behaviour
- Any other character check considered reasonable, e.g., personal references
- Any other factor that may be relevant

1.35 In addition to conviction/caution information, applicants are expected to provide details, within 48 hours of all warnings, driving endorsements (driving convictions)/disqualification periods relating to traffic offences, fixed penalties, penalty charge notices, community resolutions and any other similar sanctions, together with any charges or arrests that they are the subject of in connection with criminal offences, whether or not actually charged with the offence, and details of any allegations of involvement in criminal activity or where they have been questioned in connection with any alleged criminal activity or inappropriate/unacceptable behaviour or any other relevant pending matter.

1.36 Where an applicant is the subject of an outstanding charge or summons, their application may continue to be processed; however, depending on the circumstances, it is unlikely that a decision on the application will be made until the conclusion of the criminal proceedings. Where the outstanding charge or summons involves a serious offence and/or the individual's offending history and behaviour/conduct indicates a pattern of unlawful or unacceptable behaviour/character traits, then the application is likely to be refused.

1.37 Where there is evidence/information that an applicant has been arrested or charged but not convicted of offences, but the nature of this evidence/information suggests the applicant may not

be a fit and proper person, the Council will give serious consideration to refusing an application or revoking an existing licence.

Fit and proper test

- 1.38 When considering an applicant's suitability to hold a hackney carriage/private hire drivers licence, to guide the Council's consideration, the implications of the answer to the following question will be applied:
- Would I allow my daughter or son, granddaughter or grandson, spouse, mother or father, or any other person I care for or any vulnerable person I know, to get into a vehicle with this person alone?
- 1.39 When considering a vehicle proprietor's suitability to apply for and hold a hackney carriage or private hire vehicle licence, to guide the Council's consideration, the implications of the answer to the following question will be applied:
- Would I be comfortable allowing this person to have control of a licensed vehicle that can travel anywhere, at any time of the day or night without arousing suspicion, and be satisfied that he/she would not allow it to be used for criminal or other unacceptable purposes, and be confident that he/she would maintain it to an acceptable standard throughout the currency of the licence?
- 1.40 When considering an applicant's suitability to hold a private hire operator licence, to guide the Council's consideration, the implications of the answer to the following question will be applied:
- Would I be comfortable providing sensitive information such as holiday plans, movements of my family or other personal information to this person, and feel safe in the knowledge that such information will not be used inappropriately or passed on for criminal or unacceptable purposes?
- 1.41 If the Council has any doubts as to the fitness of an applicant/existing licensed driver, proprietor or operator then an application must be refused or licence suspended or revoked until those doubts can be effectively allayed through the provision of further adequate evidence.
- 1.42 If the applicant or holder of a licence has notified the Council of a conviction but is appealing against it to a higher court the matter will be referred to a meeting of the Licensing Panel or the Licensing & Safety Sub-committee for a decision as to whether the licence ought to be suspended or revoked.

Patterns of behaviour

- 1.43 A series of offences or a pattern of behaviour/conduct over a period of time is more likely to give cause for concern than an isolated conviction/incident. However, that is not to say that an isolated conviction/incident cannot give cause for concern in its own right, particularly where it relates to a serious matter. In such circumstances, the Council will give significant consideration to refusing to grant a licence or to suspending and/or revoking an existing licence.
- 1.44 A serious view will always be taken where an applicant shows any tendency towards criminal and/or unacceptable/inappropriate behaviour patterns. In such instances, the Council is unlikely to consider such an applicant/existing licence holder to be a fit and proper person to hold a licence

and will give significant consideration to refusing to grant a licence or to suspending/revoking an existing licence.

Rehabilitation periods

- 1.45 Detailed guidance (effective March 2014) on the Rehabilitation of Offenders Act 1974 is available on the GOV.UK website at <https://www.gov.uk/government/publications/new-guidance-on-the-rehabilitation-of-offenders-act-1974>
- 1.46 The Rehabilitation of Offenders Act 1974 applies to everyone convicted of a criminal offence or a service disciplinary offence (for example absence without leave) by either a civilian court (in the cases of criminal offences) or a Service Court or the Commanding Officer (in the cases of criminal or Service disciplinary offences). The same rehabilitation periods apply to sentences which are imposed in the service justice system as are imposed by the civilian justice system (for example a fine imposed by a Magistrates' Court and a fine imposed by a Court Martial, would each have the same rehabilitation period of a year beginning with the date of conviction).
- 1.47 A person with a conviction for an offence need not be automatically barred from obtaining a licence. However, they would be expected to remain free of conviction for an appropriate period of time (as set out in Tables A, B and C below) and demonstrate adequate evidence that they are a fit and proper person to hold a licence. The onus is on the person to produce such evidence.
- 1.48 The specific periods of rehabilitation are not intended to be taken as definitive time periods by which an applicant/existing licence holder is automatically granted a licence simply on the basis that the rehabilitation period has elapsed. Rather they are intended to give parameters for consideration when taken with the overall history of an applicant/existing licence holder in order to assist the Council to determine whether an applicant/existing licence holder is a fit and proper person or not. The rehabilitation periods will not be considered in isolation.
- 1.49 Unless significant and exceptional circumstances apply, the Council will not grant a licence to an applicant who has been convicted of or connected with:
- Illegal sexual activity or any form of indecency.
 - An offence resulting in death of another person.
 - Any crime involving or related to or has any connection with abuse, exploitation, use or treatment of another individual irrespective of whether the victim or victims were adults or children, this includes but is not restricted to slavery, child sexual exploitation, grooming, psychological, emotional or financial abuse.
- 1.50 In addition to the above, the licensing authority will not grant a licence to any applicant who is currently on the Sex Offenders Register or on any 'barred' list.
- 1.51 On the 21 July 2020 the Secretary of State for Transport published new Statutory Taxi and Private Hire Vehicle Standards to all licensing authorities. The Standards are aimed at safeguarding children and vulnerable adults. Shropshire Council is under a legal duty, under section 177 of the Police and Crime Act 2017, to have regard to the Standards. The Standards were developed to set-out a range of robust measures to protect taxi and private hire vehicle passengers, particularly those most vulnerable.
- 1.52 There is already clear alignment between the Council's Policy and the majority of the requirements set out in the Standards. Nevertheless, for the purposes of decision making, the requirements of

the Standards (as set out in Table A below) will take precedence. Where the Standards do not apply, consideration will be given to the rehabilitation periods as set out by Rehabilitation of Offenders Act 1974 (as set out in Tables B and C below). Each application and review of an existing licence will continue to be determined on their own merits.

Table A – Statutory Taxi and Private Hire Vehicle Standards

Convictions	Rehabilitation period (applies from the end date of any sentence or driving disqualification period)
<u>Offences involving violence against a person</u> – A conviction for an offence of violence against the person, or connected with any offence of violence	10 years
<u>Possession of a weapon</u> - A conviction for possession of a weapon or any other weapon related offence	7 years
<u>Dishonesty</u> - A conviction for any offence where dishonesty is an element of the offence	7 years
<u>Drugs</u> - Any conviction for, or related to, the supply of drugs, or possession with intent to supply or connected with possession with intent	10 years
<u>Drugs</u> – A conviction for possession of drugs, or related to the possession of drugs. In these circumstances, any applicant may also have to undergo drugs testing for a period at their own expense to demonstrate that they are not using controlled drugs	5 years
<u>Discrimination</u> – A conviction involving or connected with discrimination in any form	<u>7 years</u>
<u>Drink driving/driving under the influence of drugs</u> - A conviction for drink driving or driving under the influence of drugs. In the case of driving under the influence of drugs, any applicant may also have to undergo drugs testing at their own expense to demonstrate that they are not using controlled drugs	7 years
<u>Using a hand-held device whilst driving</u> - A conviction for using a held-hand mobile telephone or a hand-held device whilst driving	5 years
<u>Motoring convictions</u> – Any other motoring convictions not listed in this table	<u>No specific period has been identified*</u>

*Rehabilitation periods for motoring convictions will be considered in accordance with the requirements of Table C below

Table B - Rehabilitation of Offenders Act 1974

Sentence	Rehabilitation period (applies from the end date of the sentence, including any licence period)	Rehabilitation period for young people under 18 at the time of conviction or the time the disposal is administered (applies from the end date of the sentence, including the licence period)

Custodial sentence* of over 48 months, or a public protection sentence**	Never spent	Never spent
Custodial sentence* of over 30 months and up to and including 48 months	7 years	3½ years
Custodial sentence* of over 6 months and up to and including 30 months	4 years	2 years
Custodial sentence of 6 months or less	2 years	18 months
Community order; Youth rehabilitation order	1 year	6 months

*Custodial sentence includes both an immediate custodial sentence and a suspended sentence, a sentence of detention in a young offenders institution, a sentence of detention under section 91 of the Powers of Criminal Courts (Sentencing) Act 2000, a detention and training order, a sentence of youth custody, a sentence of corrective training and a sentence of Borstal training .

**Public protection sentence means a sentence of imprisonment imposed for specified sexual and violent offences as set out in Schedule 15 of the Criminal Justice Act 2003. (Equivalent provisions of the Armed Forces Act 2006 are also applicable.)

Table C - Rehabilitation of Offenders Act 1974

Sentence	Rehabilitation period (applies from the date of conviction)	Rehabilitation period for for young people under 18 at the time of conviction or the time the disposal is administered
Endorsement for a road traffic offence imposed by the court or a FPN; or if a driving licence is revoked or refused on medical grounds by the DVLA (or other body responsible for issuing the driving licence)	5 years*	2½ years*
Penalty points for a road traffic offence	3 years	3 years
Driving disqualification**	When the disqualification ceases to have effect	When the disqualification ceases to have effect
Community order or youth rehabilitation order with no specified end date	2 years	2 years
Fine	1 year	6 months
Conditional discharge	Period of the order	Period of the order
Absolute discharge	None	None
Conditional caution; Youth conditional caution	3 months or when the caution ceases to have effect if earlier	3 months
Simple caution; Youth caution	Spent immediately	Spent immediately
Compensation order	On the discharge of the order (i.e. when it is paid in full); individuals must	On the discharge of the order (i.e. when it is paid in full); individuals must

	obtain and retain proof of payment from the court	obtain and retain proof of payment from the court
Binding over order; Attendance centre order; Hospital order (with our without a restriction order)	Period of the order	Period of the order
Referral order	Not available for adults	Period of the order
Reparation order	Not available for adults	None

* Where a driving licence is revoked/refused on medical grounds by the DVLA (or other body), the Council will not grant a licence until medical proof of acceptable physical and mental fitness is provided.

**'Disqualified' – refers to the period of disqualification actually served in order to take account of the fact that a court may reduce the period of disqualification; an applicant must provide evidence to prove that the court agreed a reduction in the period of disqualification.

NB Simply remaining free of conviction will not generally be regarded as adequate evidence that a person is a fit and proper person.

- 1.53 Where a person does not satisfy the rehabilitation periods referred to in the tables above, then the Council will refuse to grant a new licence or revoke or suspend an existing licence until the applicant is in a position to satisfy them.

Disclosure and Barring Service – Duty to Refer

- 1.54 Shropshire Council has a duty under the Safeguarding Vulnerable Groups Act 2006, Sections 41 and 43, to refer a person to the DBS²⁵ where the person is a regulated activity provider and Shropshire Council have withdrawn permission for said person to engage in regulated activity, because the person has either:

- Harmed or poses a risk of harm to a child or vulnerable adult, or
- Satisfied the harm test, or
- Received a caution or conviction for a relevant offence.

- 1.55 The duty also applies if Shropshire Council would or might have withdrawn permission for a person to engage in regulated activity if the person has not otherwise ceased to engage in regulated activity. This includes situations where the person was re-deployed to a non-regulated activity role or resigned or retired

- 1.56 The duty to refer applies regardless of whether another body has made a referral in relation to the same person.

Licensing offences

- 1.57 In addition to the consideration of rehabilitation periods, where an existing licence holder is found guilty of hackney carriage or private hire related offences such as, but not restricted to plying for hire, over-charging, refusing to carry disabled persons, refusing to carry an assistance dog or multiple breaches of licence conditions, licence holders will be referred to a meeting of the Licensing Panel and/or the Licensing and Safety Sub-committee with a view to determining whether the licence ought to be suspended or revoked.

- 1.58 The Council considers plying for hire related offences to be of a serious nature as they fundamentally pose a serious risk to public safety and undermine the licensed hackney carriage

²⁵ [Referral duty and power for local authorities and regulatory bodies - GOV.UK \(www.gov.uk\)](https://www.gov.uk/government/topics/referral-duties)

regime. As a result, unless significant exceptional circumstances apply, there will be a presumption that the licence of the driver who committed the offence will be revoked. In addition, where there is evidence that any private hire operator continues to employ drivers who are found to be plying for hire then serious consideration will also be given to revoking the private hire operator licence.

Exceptional circumstances

- 1.59 Each application or review of a licence will be decided on its merits. Where a person does not satisfy the requirements of the Policy there is a presumption that unless an applicant can demonstrate exceptional circumstances the Council will refuse to grant a new licence or revoke or suspend an existing licence. Whilst it is neither possible nor prudent to draw up a list of what might amount to exceptional circumstances, an applicant who claims that exceptional circumstances exist will be expected to be able to satisfy the Council that it would not frustrate the purposes of the legislation or compromise public safety if the licence were granted, renewed or if were not suspended or revoked as the case may be.

Right of appeal

- 1.60 Any applicant refused a driver, proprietor or operator licence on the grounds that they are not a fit and proper person to hold such a licence, or who has had their licence suspended or revoked or had a condition attached with which they disagree has a right of appeal by way of written complaint, to the Magistrates' Court²⁶ within 21 days of the notice of decision being served upon them.
- 1.61 Should an appeal be lodged by any applicant refused a driver, proprietor or operator licence on the grounds that they are not a fit and proper person to hold such a licence, or who has had their licence suspended or revoked, the onus is on the Council to prove that they are no longer a fit and proper person.

Conclusion

- 1.62 Any applicant having a previous or current conviction should not, in principle, debar them from obtaining a hackney carriage or private hire driver's licence, private hire vehicle proprietor's licence or operator's licence. However, previous convictions are a significant factor in the decision-making process and it will inevitably be more difficult for such applicants to obtain a licence. It is this Council's policy to consider the protection of the public above all else by ensuring all licensed drivers, proprietors and operators are honest, will not be a threat to the public, are in good health, are safe and competent drivers and are able to maintain their vehicles to a safe standard. In doing so, the Council will focus on the background of an applicant as a whole and will not consider individual offences and their rehabilitation periods identified above in isolation from other factors, in particular patterns of unacceptable or inappropriate behaviour and conduct that may not necessarily be linked to proven convictions.
- 1.63 The Council will not consider the impact of hardship on the applicant and his family when making a determination on an application or reviewing an existing licence.²⁷

²⁶ With the exception of an application for a new hackney carriage licence which has a right of appeal to Crown Court

²⁷ *Leeds City Council v Hussain* [2002] EWHC 1145 (Admin), [2003] RTR 199 and *Cherwell District Council v Anwar*[2011] EWHC 2943 (Admin)

APPENDIX J

SPECIFICATIONS FOR A REFERENCE WHEELCHAIR

SPECIFICATION FOR A REFERENCE WHEELCHAIR

- 1.0 All wheelchair accessible vehicles must be capable of carrying at least one “reference wheelchair” and where the user of a reference wheelchair can enter, alight and travel in the passenger compartment in safety and reasonable comfort whilst remaining seated in their wheelchair.
- 1.1 As there are numerous shapes and sizes of wheelchair the Department for Transport consider a reference wheelchair to be as illustrated below²⁸:

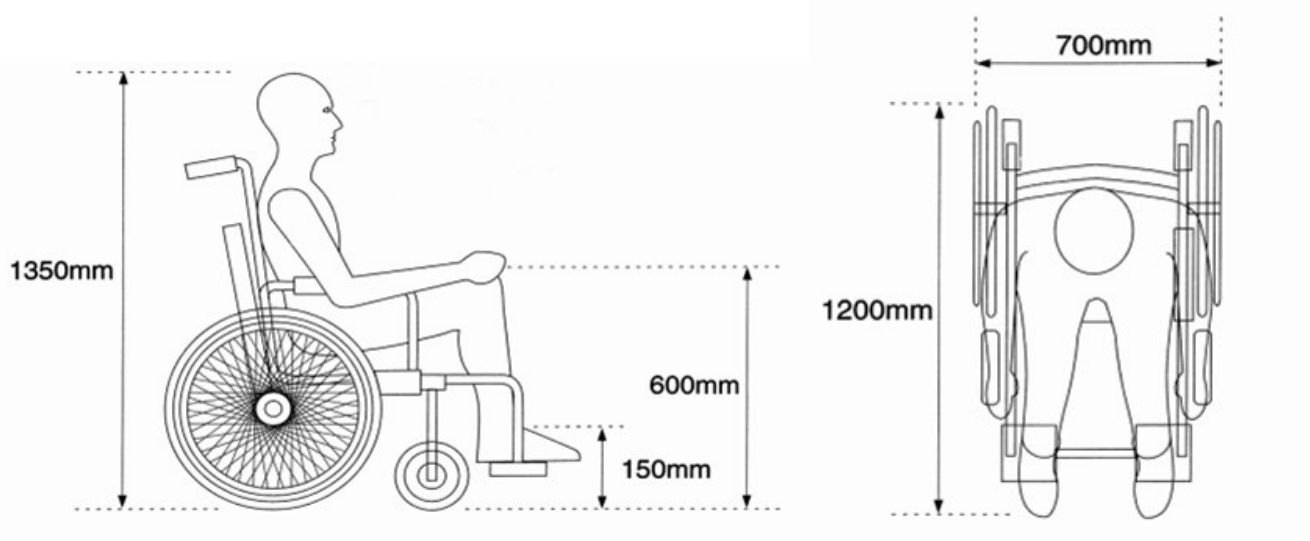

²⁸ As defined in Schedule 1 and 2 of the Public Service Vehicle Accessibility Regulations 2000

APPENDIX K

INTENDED USE

AND

LICENSING OF

HACKNEY CARRIAGES

INTENDED USE AND LICENSING OF HACKNEY CARRIAGES

Reasons for Policy

- 1.0 The Council wishes to ensure that applications for the grant of hackney carriage licences are determined in accordance with the guidance given by the High Court in its judgment, and the declaration made in the case of Newcastle City Council v Berwick upon Tweed Council [2008].

Applications for the grant of a new hackney carriage licence

- 1.1 Applicants for new licences will be expected to demonstrate a bona fide intention to ply for hire within the administrative area of Shropshire Council under the terms of the licence for which application is being made.
- 1.2 There will be a presumption that applicants who do not intend to a material extent to ply for hire within the administrative area of Shropshire Council will not be granted a hackney carriage licence authorising them to do so. Each application will be decided on its individual merits.
- 1.3 Even where the applicant intends to ply for hire to a material extent in the administrative area of Shropshire Council, if the intention is to trade in another authority's area also for a substantial amount of time (and it appears that the purpose of the legislation and public safety will be frustrated) then, subject to the merits of the particular application, there will be a presumption that the application will be refused.

Applications for the renewal of a hackney carriage licence

- 1.4 Applicants for renewals of licences will be required to inform the Council whether they have a bona fide intention to ply for hire within the administrative area of Shropshire Council under the terms of the licence for which application is being made.
- 1.5 There will be a presumption that applicants who do not intend to a material extent to ply for hire within the administrative area of Shropshire Council will not be granted a hackney carriage licence authorising them to do so. Section 60 of Local Government (Miscellaneous Provisions) Act 1976 gives the Council a broad discretion to refuse to renew a licence for any reasonable cause. Each application will be decided on its merits.
- 1.6 Even where the applicant intends to ply for hire to a material extent in the administrative area of Shropshire Council, if the intention is to trade in another authority's area also for a substantial amount of time (and it appears that the purpose of the legislation and public safety will be frustrated) then, subject to the merits of the particular application, there will be a presumption that the application will be refused.

Transfer of ownership – when a licensed vehicle is transferred from one person to another

- 1.7 Section 49 of the Local Government (Miscellaneous Provisions) Act 1976 requires that the proprietor of the licensed vehicle who transfers his interest to another must, within 14 days of the transfer, give written notice to the Council of the name and address of the transferee of the

hackney carriage. The Council has no power to refuse to register the new proprietor: see *R v Weymouth Borough Council, ex p Teletax (Weymouth) Ltd* [1947] KB 583.

- 1.8 Provided requisite notice has been given in accordance with section 49 of the Local Government (Miscellaneous Provisions) Act 1976 the Council will register the transferee of a licensed hackney carriage as the new proprietor. This is a legal requirement.
- 1.9 The transferee of a licensed hackney carriage will be asked to inform the Council whether he has a bona fide intention to use the vehicle to ply for hire within the administrative area of Shropshire Council. In addition, where the transferee resides outside the administrative area of Shropshire Council, the transferee will be required to keep records of all pickups on the Shropshire Council approved record sheets and these records shall be made available for inspection upon request. Transferees should note the obligation under section 73 of the Local Government (Miscellaneous Provisions) Act 1976 to give to an authorised officer information which may reasonably be required by him for the purpose of carrying out his functions under the legislation. Where there is a failure to provide the requested information or to keep the records, the Council will give serious consideration to exercising its powers of suspension of the licence under section 60 of the 1976 Act until such information is forthcoming, in addition to its powers under section 73.
- 1.10 Transferees of existing licences will be expected to have a bona fide intention to ply for hire within the administrative area of Shropshire Council under the terms of the licence in respect of the vehicle being transferred.
- 1.11 Where the transferee of a licensed hackney carriage is found to have no intention to ply for hire to a material extent within the administrative area of Shropshire Council and/or intends to trade in another authority's area also for a substantial amount of time (and it appears that the purpose of the legislation and public safety will be frustrated) then, subject to the merits of the particular case, consideration will be given (either at renewal or earlier) to the suspension or revocation of the licence under section 60 of the 1976 Act. Where the transferee proposes to operate remotely from the administrative area of Shropshire Council there will be a presumption that his licence will be revoked. Each case will be decided on its merits.
- 1.12 The Council is required to register the name of the new proprietor of a vehicle. It seems to the Council also to open up an obvious route to circumvent the decision of the High Court referred to in paragraph 1.0 above, unless precautionary steps are taken. The paragraphs in this section are intended to put the Council in a position to respond responsibly to the transfer of a Shropshire hackney carriage into the name of someone who operates outside the administrative area of Shropshire Council or remotely from it.
- 1.13 Unless there has been a change in the proprietor's intentions with regard to plying for hire within the administrative area of Shropshire Council, there should be no reason why he should not be granted a licence for a replacement vehicle. On the other hand, an applicant who obtained his first licence on the expressed intention of plying for hire to a material extent within the administrative area of Shropshire Council, and who on application to replace that vehicle with another discloses that he no longer so intends, effectively engages the presumption against grant that is mentioned earlier.

Change of vehicle – when a proprietor replaces a licensed vehicle

- 1.14 Applicants seeking the grant of hackney carriage licence for a vehicle intended to replace another licensed vehicle will be asked to inform the Council of their intended use of the vehicle. There will

be a presumption that applicants who no longer intend to ply for hire to a material extent within the administrative area of Shropshire Council will not have the new hackney carriage licence granted. Even where the applicant intends to ply for hire to a material extent in the administrative area of Shropshire, if the intention is to trade in another authority's area also for a substantial amount of time (and it appears that the purpose of the legislation and public safety will be frustrated) then, subject to the merits of the particular case, there will be a presumption that the application will be refused.

Revocation of licence

- 1.15 Where a licence has been granted under the terms that the applicant intends to ply for hire to a material extent within the administrative area of Shropshire Council but is subsequently found not to be plying for hire to a material extent in the administrative area of Shropshire Council and/or to be trading in another authority's area for a substantial amount of time (and it appears that the purpose of the legislation and public safety will be frustrated) there will be a presumption that the licence will be revoked.

Exceptional circumstances

- 1.16 Each application will be decided on its merits. However, the presumptions that intended use is to ply for hire to a material extent within the administrative area of Shropshire Council will be rebuttable in exceptional circumstances. Whilst it is neither possible nor prudent to draw up a list of what might amount to exceptional circumstances, an applicant who claims that exceptional circumstances exist will be expected to be able to satisfy the Council that it would not frustrate the purposes of the legislation or compromise public safety if the licence were granted, renewed or if were not suspended or revoked as the case may be.

APPENDIX L

USE OF INFORMATION ON AND IN RELATION TO HACKNEY CARRIAGES AND PRIVATE HIRE VEHICLES

USE OF INFORMATION ON AND IN RELATION TO HACKNEY CARRIAGES AND PRIVATE HIRE VEHICLES

- 1.0 Information in any form, including advertisements, images and other material, displayed on hackney carriages and private hire vehicles or contained in any advertising/promotion for a private hire operators business or in relation to any advertising/promotion for any other business offering a hackney carriage or private hire vehicle service will not be permitted by Shropshire Council if, in Shropshire Council's reasonable opinion, the information falls within any of the following categories:
- a) Does not comply with the law or incites someone to break the law
 - b) Does not comply with the UK Code of Non-broadcast Advertising, Sales Promotion and Direct Marketing
 - c) Is likely to cause widespread or serious offence to members of the public on account of the nature of the product or service being advertised the wording or design of the advertisement or by way of inference
 - d) Depicts men, women or children in a sexual manner or displays nude or semi-nude figures in an overtly sexual context (**NB** whilst the use of underdressed people in most underwear advertising may be seen as an appropriate context, gratuitous use of an overtly sexual nature will be unacceptable)
 - e) Depicts or refers to indecency or obscenity or uses obscene or distasteful language including that set out in a foreign language
 - f) Relates to lap-dancing, 'gentlemen's clubs', escort agencies or massage parlour
 - g) Depicts direct or immediate violence to anyone shown in the advertisement
 - h) Condone or provokes anti-social behaviour
 - i) Contains images or messages, which relate to matters of public controversy and sensitivity
 - j) Refers to or portrays (or gives the impression of portraying) a living person unless the written consent of that person is obtained and is produced to Shropshire Council
 - k) Contains negative references to Shropshire Council's services or those services provided or regulated by other local authorities
 - l) Relates to a political party or parties or a political cause
 - m) Relates to or advertises alcohol or tobacco (this includes electronic cigarettes and vaping)
 - n) In the case of digital media, poses a health and safety risk as a result of flickering or other visual imagery
 - o) Depicts directly or indirectly any political, racial, cultural, sexual or potentially offensive language, symbols or emblems
 - p) Depicts directly or indirectly any reference to national flags or other flags/emblems, except the national flag of the United Kingdom, the Union Flag
 - q) Where the Union Flag is displayed, it is limited to one such flag in rectangular format with dimensions no greater than 210 mm x 297 mm (equivalent to A4 paper dimensions with landscape orientation) and positioned only on the bonnet of the vehicle

APPENDIX M

CONDITIONS APPLICABLE

TO THE

USE OF TRAILERS

CONDITIONS APPLICABLE TO THE USE OF TRAILERS

- 1.0 Drivers of vehicles towing trailers must ensure that they have the correct driving licence group to permit them to tow the relevant trailer, as per the DVLA guidance Requirements for Towing Trailers in Great Britain (INF30).
- 1.1 All trailers must be of a design that when attached to the towing vehicle does not interfere in any way the operation of any rear door/emergency exits or wheelchair access ramps.
- 1.2 The use of trailers is only permitted for pre-arranged journeys where passenger's luggage cannot be safely accommodated within the vehicle.
- 1.3 The licensed towing vehicle's insurance must cover the towing of a trailer.
- 1.4 Trailers must not be left unattended anywhere on the highway.
- 1.5 The speed restrictions applicable to trailers must be observed at all times.
- 1.6 A spare wheel for the trailer and adequate tools to change a wheel must be carried at all times by a licensed vehicle whilst towing a trailer.
- 1.7 The towing of a trailer by a licensed vehicle shall only permit the conveyance of luggage and belongings owned by a passenger whilst the vehicle is hired by a passenger within the vehicle.
- 1.8 The tow bar must comply with the type approval regulations in respect of all tow bars fitted to cars after August 1998.
- 1.9 Trailers must be inspected at initial licensing and annually thereafter by a 'Nominated Tester' or Authorised Vehicle Examiner at a Vehicle Testing Station appointed under The Road Traffic Act 1988; the cost of all tests must be met by the vehicle proprietor.
- 1.10 An additional plate will be issued by the Council for each vehicle licensed to tow trailers and the relevant plate must be affixed to the rear of the trailer near the vehicle number plate.
- 1.11 Un-braked trailers shall be less than 750 kg gross weight.
- 1.12 Trailers over 750 kg gross weight shall be braked acting on at least two road wheels.
- 1.13 The towing vehicle must have a kerb weight of at least twice the gross weight of the trailer.
- 1.14 A suitable lid or other approved means of enclosure shall be fitted to secure the contents within the trailer when in use and to keep it watertight.
- 1.15 The maximum permissible length of the trailer shall be 7 metres including the drawbar and coupling.
- 1.16 The width of the trailer shall not be greater than the towing vehicle subject to no trailer being wider than 2.3 metres.

- 1.17 The maximum length for braked twin axle trailers is 5.54 metres.
- 1.18 The trailer must at all times comply with all Road Traffic legislation requirements, in particular those as laid down in the Road Vehicles (Construction and Use) Regulations 1986.
- 1.19 The trailer shall not display any form of sign, information, advertisement, image or other material not required or approved by the Council or Road Traffic legislation.